

**Case Study:  
European Offshore Wind Farms  
- A Survey for the Analysis of the Experiences  
and Lessons Learnt by Developers of  
Offshore Wind Farms -**

**Final Report**

Final Report

Deutsche WindGuard GmbH  
Deutsche Energie-Agentur GmbH (dena)  
University of Groningen

Gerhard Gerdes  
Albrecht Tiedemann  
drs. Sjoerd Zeelenberg





## Contents

<b>1</b>	<b>INTRODUCTION / ACKNOWLEDGEMENTS .....</b>	<b>1</b>
<b>2</b>	<b>EGMOND AAN ZEE (THE NETHERLANDS) .....</b>	<b>3</b>
2.1	GENERAL INFORMATION .....	3
2.2	PROJECT PLANNING PHASE .....	6
2.3	INSTALLATION AND OPERATION PHASE .....	15
2.4	LESSONS LEARNT .....	18
<b>3</b>	<b>THORNTON BANK (BELGIUM) .....</b>	<b>20</b>
3.1	GENERAL .....	20
3.2	PROJECT PLANNING PHASE .....	23
3.3	INSTALLATION AND OPERATION PHASE .....	30
3.4	LESSONS LEARNT .....	30
<b>4</b>	<b>BORKUM WEST (GERMANY) .....</b>	<b>32</b>
4.1	GENERAL .....	32
4.2	PROJECT PLANNING PHASE .....	35
4.3	INSTALLATION AND OPERATION PHASE .....	46
4.4	LESSONS LEARNT .....	46
<b>5</b>	<b>BUTENDIEK (GERMANY) .....</b>	<b>49</b>
5.1	GENERAL .....	49
5.2	PROJECT PLANNING PHASE .....	51
5.3	INSTALLATION AND OPERATION PHASE .....	56
5.4	LESSONS LEARNT .....	56
<b>6</b>	<b>GREATER GABBARD (UNITED KINGDOM) .....</b>	<b>58</b>
6.1	GENERAL .....	58
6.2	PROJECT PLANNING PHASE .....	60
6.3	INSTALLATION AND OPERATION PHASE .....	68
6.4	LESSONS LEARNT .....	68
<b>7</b>	<b>HORNS REV (DENMARK) .....</b>	<b>70</b>
7.1	GENERAL .....	70
7.2	PROJECT PLANNING PHASE .....	74
7.3	INSTALLATION AND OPERATION PHASE .....	86
7.4	LESSONS LEARNT .....	93
<b>8</b>	<b>NYSTED (DENMARK) .....</b>	<b>96</b>
8.1	GENERAL .....	96
8.2	PROJECT PLANNING PHASE .....	98
8.3	INSTALLATION AND OPERATION PHASE .....	108
8.4	LESSONS LEARNT .....	116
<b>9</b>	<b>SCROBY SANDS (UNITED KINGDOM) .....</b>	<b>118</b>
9.1	GENERAL .....	118
9.2	PROJECT PLANNING PHASE .....	121

9.3	INSTALLATION AND OPERATION PHASE .....	132
9.4	LESSONS LEARNT .....	135
<b>10</b>	<b>SUMMARY - LESSONS LEARNT .....</b>	<b>137</b>
10.1	MAIN STEPS IN PLANNING AND REALISATION OF OFFSHORE WIND FARMS .....	137
10.2	PRE-PLANNING, PROJECT PLANNING, MANAGEMENT AND APPROVAL .....	140
10.3	PROCUREMENT AND CONTRACTING .....	141
10.4	INSTALLATION AND GRID CONNECTION.....	142
10.5	ECONOMICS .....	145
10.6	OUTLOOK FOR FURTHER ACTIVITIES .....	145

## Figures

FIGURE 1-1: LOCATIONS OF ANALYSED OFFSHORE WIND FARMS .....	1
FIGURE 2-1: LOCATIONS OF OFFSHORE WIND FARM EGMOND AAN ZEE (WITHIN TERRITORIAL WATERS) AND Q7-WP (IN EEZ) (SOURCE: OFFSHORE WINDENERGIE 2005A).....	4
FIGURE 2-2: SITE LAYOUT (SOURCE: NOORDZEEWIND 2003A).....	5
FIGURE 2-3: TIME SCHEDULE OF THE OWEZ PROJECT.....	6
FIGURE 2-4: INDICATIVE OVERVIEW OF OWEZ PROJECT ORGANISATION.....	7
FIGURE 2-5: LAYOUT AND CABLE ROUTE OF OWEZ (SOURCE: NOORDZEEWIND 2003A).....	9
FIGURE 2-6: SITE LOCATION AND OTHER USAGES (SOURCE: NOORDZEEWIND 2002).....	13
FIGURE 2-7: DETAILED SITE LAYOUT (SOURCE: NOORDZEEWIND 2003A).....	13
FIGURE 2-8: GRID CONNECTION (SOURCE: NOORDZEEWIND 2003A).....	14
FIGURE 2-9: SVANEN (SOURCE: BALLAST NEDAM INFRA 2005).....	15
FIGURE 2-10: ORIGINAL INSTALLATION CONCEPT (SOURCE: BALLAST NEDAM INFRA 2005).....	15
FIGURE 2-11: FOUNDATION INSTALLATION BY SVANEN (SOURCE: BALLAST NEDAM INFRA 2005).....	16
FIGURE 3-1: GEOGRAPHICAL LOCATION OF THE WIND FARM THORNTON BANK.....	21
FIGURE 3-2: CLOSER LOOK AT THE WIND FARM AREA.....	22
FIGURE 3-3: MULTIRASHIP COMMANDER, USED FOR SITE SCANNING WITH SONAR.....	26
FIGURE 3-4: VAGANT JACK-UP PLATFORM USED FOR SOIL INVESTIGATIONS.....	26
FIGURE 3-5: DISTRIBUTION OF PROJECT COSTS FOR PHASE 1 AND PHASE 2.....	28
FIGURE 3-6: INTER-ARRAY CABLING IN THE WIND FARM. THE WIND TURBINES ARE CONNECTED VIA A 30 kV SEA CABLE TO THE OFFSHORE TRANSFORMER STATION.....	29
FIGURE 3-7: THE CABLE LANDING WILL BE DONE BY A VERTICAL DRILLING BELOW THE SAND DUNES AT THE SEA COAST.....	29
FIGURE 3-8: THE ROUTE OF THE SEA CABLE FROM THE OFFSHORE WIND FARM TO LAND (LEFT) AND FROM THE LANDING POINT TO THE ONSHORE SUBSTATION (RIGHT).....	30
FIGURE 3-9: THE GRID CONNECTION POINT AT THE HIGH VOLTAGE (150kV) SUBSTATION AT SLIJKENS IN BREDENE, OOSTENDE.....	30
FIGURE 4-1: THE WIND FARM AREA IS PLANNED OUTSIDE THE 12 SEA MILE ZONE WITHIN THE EXCLUSIVE ECONOMIC ZONE (AUSSCHLIEßLICHE WIRTSCHAFTSZONE = AWZ) OF GERMANY. THE AREA LIES BETWEEN THE TWO IMPORTANT TRAFFIC SEPARATION ZONES. IN THE PILOT PHASE ONLY 60 MW ARE PLANNED TO BE INSTALLED, IN THE COMPLETION PHASE A TOTAL OF 1000 MW.....	33
FIGURE 4-2: SEVEN DIFFERENT PROPOSALS FOR THE SEA CABLE ROUTES (SOURCE: PROKON NORD).....	38
FIGURE 4-3: HEAT DISTRIBUTION AROUND THE AC CABLE PLANNED FOR THE PILOT PHASE (AFTER 450 DAYS, DURING WINTER).....	39
FIGURE 4-4: RESEARCH SHIP VICTOR HENSEN (SOURCE: PROKON NORD).....	40
FIGURE 4-5: PICTURES FROM SITE SCREENING INVESTIGATIONS (SOURCE: PROKON NORD).....	41
FIGURE 4-6: PLOT OF THE SEABED SURFACE RECORDED DURING A SITE SCAN (SOURCE: PROKON NORD).....	42
FIGURE 4-7: RESEARCH PLATFORM "FINO".....	42
FIGURE 4-8: DIFFERENT FOUNDATION TYPES.....	44
FIGURE 4-9: PLANNED CABLE ROUTE TO CONNECT THE WIND FARM (BLUE RECTANGLE IN THE UPPER LEFT CORNER) WITH THE ONSHORE CONNECTION POINT.....	45
FIGURE 4-10: ONSHORE CABLE ROUTE.....	46
FIGURE 4-11: STANDARD CONCEPTS FOR EIA AND SITE AND SEABED INVESTIGATIONS.....	47
FIGURE 5-1: PLANNED OFFSHORE WIND FARM WITHIN THE GERMAN EEZ, THE LOCATION OF BUTENDIEK IS INDICATED BY A YELLOW CIRCLE.....	50
FIGURE 5-2: GEOGRAPHICAL POSITION OF BUTENDIEK WIND FARM.....	50
FIGURE 5-3: OFFSHORE CABLE ROUTE ACROSS THE NORTH FRISIAN ISLAND OF SYLT.....	53
FIGURE 5-4: DRILLING AND CONIC PENETRATION TEST WITH A PLATFORM FROM MOHIBA.....	53
FIGURE 6-1: LOCATION OF THE GREATER GABBARD OFFSHORE WIND FARM AND ROUTE OF EXPORT CABLES FROM WIND FARM TO SIZEWELL.....	59
FIGURE 6-2: LOCATION OF ONSHORE CABLE AND ONSHORE SUB-STATION AT SIZEWELL OF GREATER GABBARD OFFSHORE WIND FARM.....	59
FIGURE 6-3: TIMETABLES FOR ONSHORE AND OFFSHORE WORKS OF GREATER GABBARD OFFSHORE WIND FARM.....	60
FIGURE 7-1: VIEW OF THE HORNS REV WIND FARM.....	70
FIGURE 7-2: GEOGRAPHICAL MAP SHOWING THE LOCATION OF THE HORNS REV WIND FARM AT ESBJERG.....	71
FIGURE 7-3: TIMETABLE OF THE PLANNING AND INSTALLATION PROCESS IN HORNS REV.....	72
FIGURE 7-4: TIMETABLE OF THE PRODUCTION AND INSTALLATION PROCESS ONLY.....	73
FIGURE 7-5: TIME SCHEDULE FOR SITE WORKS.....	74
FIGURE 7-6: LOCATIONS FOR OFFSHORE WIND FARM IDENTIFIED IN THE NATIONAL SCREENING PROCESS.....	75
FIGURE 7-7: MEASUREMENT TOWER AT HORNS REV (SOURCE: ELTRA).....	78
FIGURE 7-8: FREQUENCY DISTRIBUTION OF WIND DIRECTION. THE WIDE DISTRIBUTION FROM NORTHEAST TO SOUTH GIVES NO MAIN ORIENTATION FOR THE WIND FARM SPACING (SOURCE ELSAM).....	80

FIGURE 7-9: THE VESTAS V80 WIND TURBINE SELECTED FOR THE HORNS REV OFFSHORE WIND FARM (SOURCE: ELSAM). .....	81
FIGURE 7-10: ROUTE OF POWER LINE ON LAND (SOURCE: ELTRA). .....	82
FIGURE 7-11: SCHEMATIC DIAGRAM OF THE HORNS REV GRID CONNECTION, SHOWING IN EXAMPLE THE SINGLE TURBINES, MEDIUM VOLTAGE SWITCHES, TRANSFORMER STATIONS FROM 36 kV TO 170 kV, THE 21 KM SEA CABLE AND 34 KM CABLE ON LAND TO THE 170 kV CONNECTION POINT (SOURCE: ELTRA). .....	83
FIGURE 7-12: CABLING OF HORNS REV WIND FARM (SOURCE: ELSAM). .....	84
FIGURE 7-13: SUB-MARINE CABLE (SOURCE: ELTRA). .....	85
FIGURE 7-14: PILE DRIVING (LEFT) AND INSTALLATION OF THE TRANSITION PIECE (RIGHT) WAS CARRIED OUT BY JACK-UP PLATFORMS FROM BALLAST NEDAM (SOURCE: GUNNAR BRITSE). .....	87
FIGURE 7-15: LEFT: "ASIAN HERCULES" DELIVERING THE 1200-TONNE SUBSTATION (SOURCE: ELTRA). RIGHT: THE READY INSTALLED 36 kV TO 150 kV SUBSTATION (SOURCE: GUNNAR BRITSE). THE MEDIUM VOLTAGE CABLES FROM THE TURBINES ARE CONNECTED TO THIS SUBSTATION. ....	88
FIGURE 7-16: THE CRANE VESSEL "OCEAN HANNE" WAS USED FOR TURBINE TRANSPORT AND INSTALLATION (SOURCE: GUNNAR BRITSE). .....	88
FIGURE 7-17: TURBINE ASSEMBLY AREA IN THE HARBOUR AND SHIPPING OUT OF THE HARBOUR (SOURCE: GUNNAR BRITSE). .....	89
FIGURE 7-18: INSTALLATION OF TOWER (LEFT) AND ROTOR BLADES (RIGHT) (SOURCE: GUNNAR BRITSE). .....	90
FIGURE 7-19: SKETCH AND PICTURES OF THE CABLE-LAYING SHIP "H.P. LADING". .....	91
FIGURE 8-1: MAP OF AREA OF NYSTED OFFSHORE WIND FARM. ....	97
FIGURE 8-2: PROJECT STRUCTURE OF NYSTED OFFSHORE WIND FARM. ....	99
FIGURE 8-3: TIME SCHEDULE FOR ENVIRONMENTAL INVESTIGATIONS AT NYSTED OFFSHORE WIND FARM . ....	101
FIGURE 8-4: GRAVITY FOUNDATION FOR NYSTED OFFSHORE WIND FARM. ....	105
FIGURE 8-5: FOUNDATION AND SCOUR PROTECTION FOR NYSTED OFFSHORE WIND FARM (SOURCE: AARSLEFF). .....	106
FIGURE 8-6: GRID CONNECTION OF NYSTED OFFSHORE WIND FARM AND REINFORCEMENT OF TRANSMISSION GRID OF LOLLAND / FALSTER / ZEALAND. ....	107
FIGURE 8-7: PRODUCTION SITE FOR GRAVITY FOUNDATIONS IN ODRAPORT - SWINOUJSCIE, POLAND (SOURCE: AARSLEFF). .....	108
FIGURE 8-8: INSTALLATION OF WIND TURBINES, PILES AND BLADES AT NYSTED OFFSHORE WIND FARM WITH MS OCEAN ADY. ....	110
FIGURE 8-9: LOGISTIC CENTRE IN PORT OF NYBORG (DENMARK) .....	113
FIGURE 8-10: CONSTRUCTION AND INSTALLATION OF THE NYSTED WIND FARM TRANSFORMER STATION (SOURCE: BLADT INDUSTRIES A/S). .....	114
FIGURE 8-11: EXPECTED NUMBER OF VISITS AT NYSTED OFFSHORE WIND FARM DURING WIND FARM LIFETIME. ....	115
FIGURE 8-12: SMALL BOAT ACCESS FOR OPERATION AND MAINTENANCE SERVICES AT NYSTED (SOURCE: ENERGI E2). .....	115
FIGURE 9-1: LOCATION OF SCROBY SANDS OFFSHORE WIND FARM. ....	120
FIGURE 9-2: COMPANIES INVOLVED IN THE SCROBY SANDS OFFSHORE WIND FARM (MAIN CONTRACTS). ....	122
FIGURE 9-3: SCROBY SANDS INFORMATION CENTRE IN GREAT YARMOUTH. ....	123
FIGURE 9-4: SCROBY SANDS – MAN-HOURS DURING CONSTRUCTION AND OPERATION PHASE (2003 – 2005). .....	129
FIGURE 9-5. LOCATION OF TURBINES AT SCROBY SANDS. ....	131
FIGURE 9-6: CABLE TO SHORE FROM SCROBY SANDS OFFSHORE WIND FARM TO SUBSTATION. ....	132
FIGURE 9-7: HARBOUR LOGISTICS IN LOWESTOFT . ....	133
FIGURE 9-8: SMALL BOAT ACCESS TO SCROBY SANDS OFFSHORE WIND FARM. ....	134
FIGURE 9-9: AVAILABILITY AND GENERATION OF ELECTRICITY AT SCROBY SANDS WIND FARM. ....	135
FIGURE 10-1: FLOWCHART OF MAIN WORK PACKAGES PHASES OF OFFSHORE WIND FARM PLANNING AND REALISATION. ....	139
FIGURE 10-2: SINGLE STEPS IN THE COMPLETION OF OFFSHORE WIND FARMS FROM MANUFACTURING TO START OF OPERATION. AN INTERFACE MAY BE REQUIRED BETWEEN EACH STEP. ....	141

## Tables

TABLE 2-1: RELEVANT CONSENTS AND ACTS DURING THE PLANNING AND PREPARATION PHASE OF OWEZ.....	8
TABLE 2-2: FINANCIAL REGULATIONS AND CONDITIONS APPLICABLE TO OWEZ.....	12
TABLE 3-1: GENERAL DESCRIPTION OF OFFSHORE WIND FARM THORNTON BANK.....	20
TABLE 3-2: TECHNICAL DATA OF OFFSHORE WIND FARM THORNTON BANK.....	21
TABLE 3-3: TIME SCHEDULE FOR THORNTON BANK.....	22
TABLE 3-4: ECONOMIC FIGURES FOR THORNTON BANK.....	27
TABLE 4-1: GENERAL DESCRIPTION OF OFFSHORE WIND FARM BORKUM WEST.....	32
TABLE 4-2: TECHNICAL DATA OF BORKUM WEST OFFSHORE WIND FARM.....	33
TABLE 4-3: CURRENT SCHEDULE OF THE BORKUM WEST PROJECT.....	34
TABLE 4-4: REQUIRED PERMISSIONS FOR THE SEA CABLE.....	36
TABLE 4-5: LAYING DEPTH OF THE SEA CABLE IN DIFFERENT SEA AREAS.....	38
TABLE 4-6: ECONOMIC FIGURES OF THE PILOT PHASE.....	43
TABLE 5-1: GENERAL DESCRIPTION OF BUTENDIEK OFFSHORE WIND FARM.....	49
TABLE 5-2: TECHNICAL DATA OF BUTENDIEK OFFSHORE WIND FARM.....	49
TABLE 5-3: PROJECT COSTS.....	54
TABLE 5-4: SHARES BY PRIVATE PEOPLE FOR PLANNING AND PROJECT EQUITY CAPITAL.....	54
TABLE 5-5: EQUITY AND OUTSIDE CAPITAL FOR THE TOTAL PROJECT FINANCING.....	55
TABLE 5-6: GRID CONNECTION VOLTAGE LEVELS.....	56
TABLE 6-1: GENERAL DESCRIPTION OF THE GREATER GABBARD OFFSHORE WIND FARM.....	58
TABLE 6-2: TECHNICAL DATA OF THE GREATER GABBARD OFFSHORE WIND FARM.....	58
TABLE 6-3: COMPANIES AND INSTITUTIONS SUPPORTING GREATER GABBARD OFFSHORE WINDS LTD IN APPROVAL PROCEDURES.....	61
TABLE 6-4: PERMITS NEEDED FOR GREATER GABBARD OFFSHORE WIND FARM.....	62
TABLE 6-5: DISTRIBUTION OF ENVIRONMENTAL IMPACT ASSESSMENT SCOPING REPORT FOR GREATER GABBARD OFFSHORE WIND FARM.....	65
TABLE 6-6: PROPERTIES OF REPRESENTATIVE CURRENT AND FUTURE GENERATION WIND TURBINES FOR GREATER GABBARD OFFSHORE WIND FARM.....	67
TABLE 7-1: TECHNICAL DATA OF THE CONNECTION OFFSHORE WIND FARM TO SHORE.....	84
TABLE 7-2: TECHNICAL DATA OF THE GRID CONNECTION ONSHORE.....	85
TABLE 8-1: GENERAL PROJECT DESCRIPTION OF NYSTED OFFSHORE WIND FARM.....	96
TABLE 8-2: TECHNICAL DATA OF NYSTED OFFSHORE WIND FARM.....	97
TABLE 8-3: PROGRAMME AND DURATION OF ENVIRONMENTAL STUDIES AT NYSTED OFFSHORE WIND FARM.....	102
TABLE 8-4: ECONOMICS OF NYSTED OFFSHORE WIND FARM.....	103
TABLE 9-1: GENERAL DESCRIPTION OF SCROBY SANDS OFFSHORE WIND FARM.....	118
TABLE 9-2: TECHNICAL DATA OF SCROBY SANDS OFFSHORE WIND FARM.....	119
TABLE 9-3: SCOPE AND DURATION OF ENVIRONMENTAL MONITORING PROGRAMMES AT SCROBY SAND OFFSHORE WIND FARM.....	125
TABLE 9-4: SCROBY SANDS - VALUE BY PHASE.....	127
TABLE 9-5: DETAILS OF COSTS IN DEVELOPMENT, CONSTRUCTION AND OPERATION PHASE OF SCROBY SANDS OFFSHORE WIND FARM.....	128
TABLE 9-6: SCROBY SANDS - VALUE OF THE MAIN COMPONENTS DURING THE CONSTRUCTION PHASE.....	129
TABLE 10-1: IMPORTANT WORK PACKAGES DURING MAIN PHASES OF OFFSHORE WIND PLANNING AND REALISATION.....	138
TABLE 10-2: INSTALLATION OF OFFSHORE WIND FARMS (WF NO. 4 ISN'T CONSTRUCTED YET).....	143
TABLE 10-3: SUMMARY OF THE EIGHT INVESTIGATED OFFSHORE WIND FARMS.....	144

## Glossary

£/MW	Pounds per megawatt
£m	Pounds-millions
AC	Alternating current
AMSL	Above Medium Sea Level
AWZ	Ausschließliche Wirtschaftzone (Exclusive Economic Zone)
BCE	Bouwcombinatie Egmond
BMU	Bundesministerium für Umwelt, Naturschutz und Reaktorsicherheit (Federal Ministry for the Environment, Nature Conservation and Nuclear Safety)
BSH	Bundesamt für Seeschifffahrt und Hydrographie (Federal Maritime and Hydrographic Agency)
BWEA	British Wind Energy Association
CCW	Countryside Council of Wales
CEFAS	Centre for Environment, Fisheries and Aquaculture Science
COWRIE	Collaborative Offshore Wind Research into the Environment
CPA	Coast Protection Act
CRINE	Cost Reduction In a New Era
DC	Direct current
DEFRA	UK government's Department for Environment, Food and Rural Affairs
DTI	Department of Trade and Industry
DTLR	Department for Transport, Local Government and the Regions
DWL	Douglas-Westwood Limited
East of Eng-land	Bedfordshire, Cambridgeshire, Essex, Hertfordshire, Norfolk and Suffolk
EC	European Commission
EEDA	East of England Development Agency
EEEGR	East of England Energy Group
EEZ	Exclusive Economic Zone
EMA	Environmental Management Act
EIA	Environmental impact assessment
EIS	Environmental impact statement
EMF	Electromagnetic fields
EPC	Engineering, procurement and commissioning
EPIC	Engineering, procurement, installation and construction
EROWL	E.ON UK Renewables Offshore Wind Ltd
EU	European Union
EWEC	European Wind Energy Conference
FEPA	Food and Environmental Protection Act
GBS	Gravity-Base Structure
Greater Wash	From the north Norfolk coast towards Flamborough Head and out into the North Sea
GW	Gigawatt
HVAC	High Voltage Alternating Current
HVDC	High Voltage Direct Current
HSE	Health Safety and Environment
HVDC	High voltage direct current
KPD	Key Planning Decision
kV	Kilovolt
kW	Kilowatt
kWh	Kilowatt hour
Mapergy	An internet-based supply chain mapping system developed by EEEGR
MEP	Monitoring and Evaluation Programme
MSL	Mean Sea Level
MW	Megawatt
NSW	Near Shore Wind Farm

NERC	Natural Environment Research Council
nmi	international nautical mile, 1nmi = 1852,01m
North West	The eastern Irish Sea between the north Wales coast and the Solway Firth
O&M	Operations & maintenance
ODE Ltd	Offshore Design Engineering Limited
OJEC	Official Journal of the European Community
OSPAR	Oslo & Paris Convention for the Protection of the Marine Environment of the Northeast Atlantic
OWEZ	Offshore Wind Farm Egmond aan Zee
PES	Public energy supply
POWER	Pushing Offshore Wind Energy Regions
PWA	Public Works Act
RAMSA	Convention on Wetlands (intergovernmental treaty adopted in the Iranian city of Ramsar)
R&D	Research & development
Round 1	1st round of UK offshore wind farms – located within 12 nautical mile limit
Round 2	2nd round of UK offshore wind farms – focussed on 3 strategic areas in territorial waters
RSPB	Royal Society for the Protection of Birds
SCADA	Supervisory control and data acquisition systems
SEA	Strategic Environmental Assessment Directive
SIC	Standard Industry Classification
SNS	Southern North Sea
Strategic Areas	Defined as: Thames Estuary, Greater Wash & North West Standarduntersuchungskonzept für die Untersuchung und Überwachung der Auswirkungen von Offshore Windenergieanlagen auf die Meeresumwelt (standard concept for the investigation and monitoring of effects of off-shore wind farms on the ocean environment)
StUK	United Kingdom
UK	United Kingdom
Var	Volt-ampere reactive (reactive power)
WTG	Wind Turbine Generator
.	decimal seperator
,	1000 seperator



## 1 Introduction / Acknowledgements

The purpose of the Case Study of European Offshore Wind Farms is to gather and evaluate experiences and lessons learnt from planning and development procedures from eight offshore wind farms in Belgium, Denmark, Germany, Great Britain and the Netherlands. The main objective is to derive information and recommendations for future wind farm projects. The results will be made available to developers, planners and operators, as well as to national and European authorities.

The research work was carried out jointly by Deutsche WindGuard GmbH, the German Energy Agency GmbH (dena) and the University of Groningen (Faculty of Spatial Sciences). It is a sub-project within the EU funded project "Pushing Offshore Wind Energy Region (POWER)". The case study was carried out on behalf of the Senator for Construction, Environment and Transport of the German State of Bremen.

The German Energy Agency analysed three of the eight wind farms, Nysted, Denmark, and Scroby Sands and Greater Gabbard, both in the United Kingdom; the University of Groningen examined the facility at Egmond aan Zee, the Netherlands; and the Deutsche WindGuard GmbH studied the wind farms at Horns Rev, Denmark, Borkum West, Germany, Butendiek, Germany and Thornton Bank, Belgium. These projects were chosen because they cover a wide range of conditions: online/ planned, and long distance to shore/ near shore, as well as the different national frameworks.

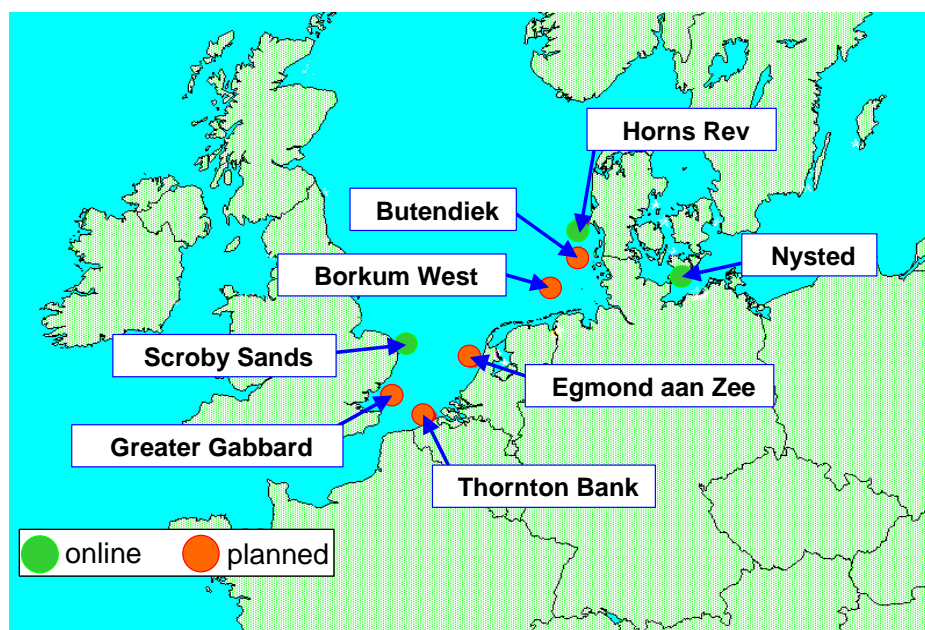

Figure 1-1: Locations of analysed Offshore Wind Farms

The research work is based on desktop and internet research, as well as interviews with experts. Without their very detailed, generous contributions, many aspects of the wind farms would not have been available for the report. The authors wish to extend their sincere thanks to the persons interviewed. The interviews were held from September to November 2005. For some of the topics in which interest had been expressed, no information was available. Some of the information provided is confidential, and is therefore cited only very generally. The Study gives an overview of the planning and realisation of the eight offshore wind farms. Lessons learnt are highlighted for each. Finally, the main recommendations are summarised.

Although the information contained in this document is believed to be accurate, the authors cannot guarantee its completeness, accuracy or fairness, nor can they accept any responsibility for such information – be it in terms of fact, opinion or a conclusion drawn by the reader.

The study is structured into eight separate chapters which show the facts and results of the eight wind farms investigated. Each of these chapters is structured in the same manner; first, general information on the specific project is presented, followed by descriptions of the project planning phase and of the installation and operational phases. A further subchapter summarizes the lessons learnt in the specific project.

While the basic structure of these eight chapters is uniform, the content is not. The density of the different items and the amount of details described vary largely. E.g., the description of the installation process for the planned wind farms contains only the planned procedures and methods, while the already realised projects at Horns Rev, Nysted and Scroby Sands describe many more details on the work performed. On the other hand, the description of the planning phase is a smaller portion of the chapters of these three wind farms. The questionnaire underlying the investigations of the eight projects represents an extensive range of subjects, which has provided the basis for a broad description of each project.

The last chapter, Chapter 10, summarizes the lessons learnt from the eight offshore wind farms. Although they show broad differences in the way they are planned, investigated and developed, an attempt has been made to find recommendations based on the totality of experience. The summary provides a general overview on the most important work packages of an offshore wind farm project, a short table on its basic technical and economic figures, and a sketch of procedures for the realisation of the planned and future projects.

The study provides basic input to the POWER project, as it gives exemplarily insight into a number of European projects with a variety of aspects and focal points. A guide for actors could take information from this study to define the most relevant points for recommendations in the field of offshore wind energy development.

More information on the POWER Project is available at [www.offshore-power.net](http://www.offshore-power.net), and on offshore wind energy at [www.offshore-wind.de](http://www.offshore-wind.de).

## 2 Egmond aan Zee (The Netherlands)

### 2.1 General information

#### 2.1.1 Project description

Offshore wind farm Egmond aan Zee (OWEZ) is the first wind farm to be built in the Dutch North Sea. The project was formerly known as Near Shore Wind farm (NSW). It serves as a pilot project and is located in territorial waters near Egmond aan Zee. After a preparation period of over five years, the final investment decisions were taken in May 2005. OWEZ is owned and financed by NoordzeeWind and will be developed by Bouwcombinatie Egmond (BCE). These consortia have been formed, respectively, by Shell Wind Energy and Nuon Renewable Energy and by Ballast Nedam Infra and Vestas.

Table 1. General description of offshore wind farm Egmond aan Zee.

<b>Project description Egmond aan Zee</b>	
Project name	Offshore Wind Farm Egmond aan Zee
Country	The Netherlands
Owner / Investor	NoordzeeWind (joint venture of Shell Wind Energy and Nuon Renewable Energy)
Developer	Bouwcombinatie Egmond (joint venture of Ballast Nedam Infra and Vestas)
Operator	NoordzeeWind
Location, geographical position	10-18 kilometres off the Dutch coast of Egmond aan Zee
Area	30 km <sup>2</sup>
Water depth	15-20 metres
Distance to shore	10-18 kilometres
Operator's website	<a href="http://www.noordzeewind.nl/">http://www.noordzeewind.nl/</a>

OWEZ is the only wind farm within Dutch territorial waters. A second, fully-licensed project called Q7-WP, is expected to be built just outside the 12 nautical miles zone, in the Exclusive Economic Zone (EEZ). Both projects are depicted in Figure 2-1.

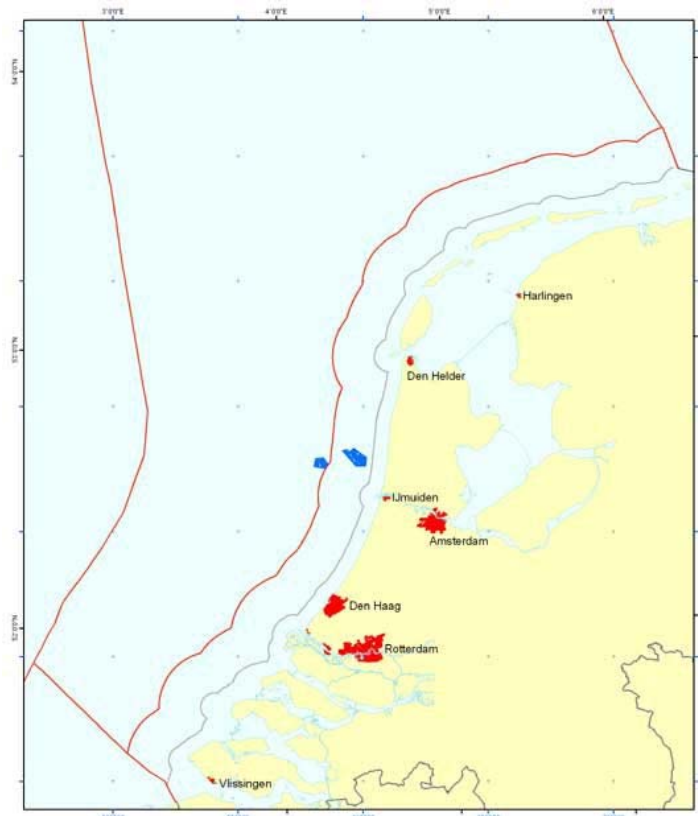

Figure 2-1: Locations of Offshore Wind Farm Egmond aan Zee (within territorial waters) and Q7-WP (in EEZ) (source: Offshore Windenergie 2005a).

### 2.1.2 Technical data

Technical specifications of Offshore Wind Farm Egmond aan Zee are displayed in table 2 and figure 2.

Table 2. Technical data of OWEZ.

Technical data Egmond aan Zee	
Total capacity	108 MW
Number of turbines	36
Turbine manufacturer and rating	Vestas V90, 3MW
Hub height	70 metres above Mean Sea Level (MSL)
Rotor diameter	90 metres

As can be seen in Figure 2-2, three sub-sea cables will connect OWEZ to the shore at IJmuiden. IJmuiden belongs to the municipality of Velsen. The IJmuiden harbour will be used for construction and maintenance works as well.

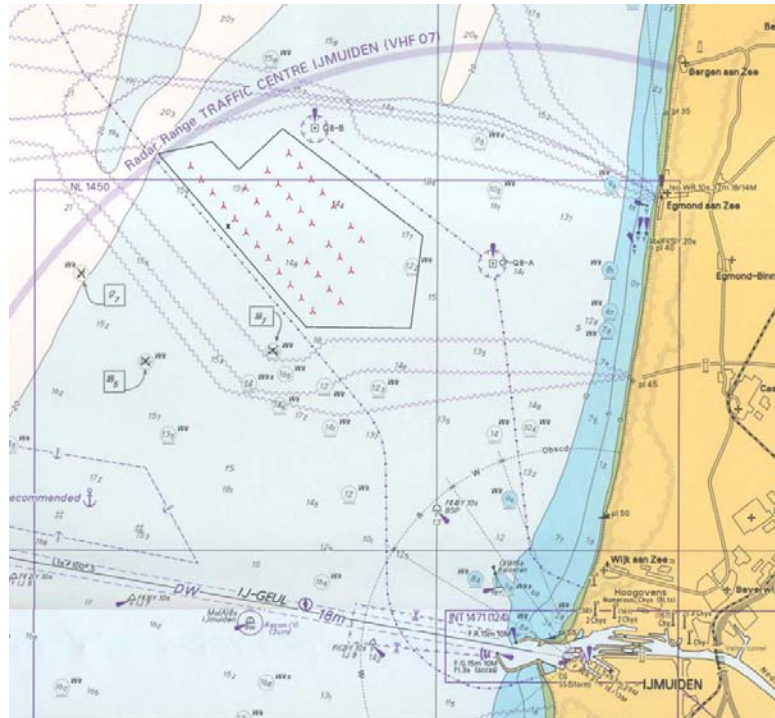

Figure 2-2: Site layout (source: NoordzeeWind 2003a).

### 2.1.3 Time frame

The initial preparations of OWEZ date from 1997, when the Dutch government decided to start a Dutch pilot project. A Key Planning Decision (KPD) procedure had to be carried out, which implied extensive stakeholder participation and inter-governmental consultation. By means of a location Environmental Impact Assessment (location EIA), the area off the coast of Egmond aan Zee was determined as the best suitable, out of six alternatives. The EIA was completed in February 2000 and included environmental, technical and economic considerations. Based on this EIA, the KPD procedure could be started. The KPD became definitive April 2002. Final appeals were rejected March 2003.

NoordzeeWind was selected as developer by means of a tender in July 2002. This consortium was granted the sole right to commence consent procedures, apply for financial support regulations and execute a benchmark environmental research programme. Consent regarding offshore installations had to be obtained due to two acts: the Public Works Act (PWA) and the Environmental Management Act (EMA). A second EIA had to be conducted with regard to the spatial configuration of the wind farm. Final appeals concerning the methods to estimate bird losses were rejected in January 2005. At the same time, the applicable financial support became definitive (see section 2.2). Onshore, several permits had to be obtained. For a complete overview of the planning and legislative process, see section 2.1.

The final investment decisions by Shell Wind Energy and Nuon Renewable Energy were taken in May 2005. Bouwcombinatie Egmond was appointed at an earlier stage, based on a lump-sum, turnkey EPC contract (see 2.1). Construction works on onshore installations took place at the end of 2005. Offshore construction is scheduled to commence in March 2006, and the wind farm will be fully commissioned by the end of 2006 (Kouwenhoven 2005). Figure 2-3 provides an overview. After a period of 20 years, OWEZ will be dismantled by NoordzeeWind.

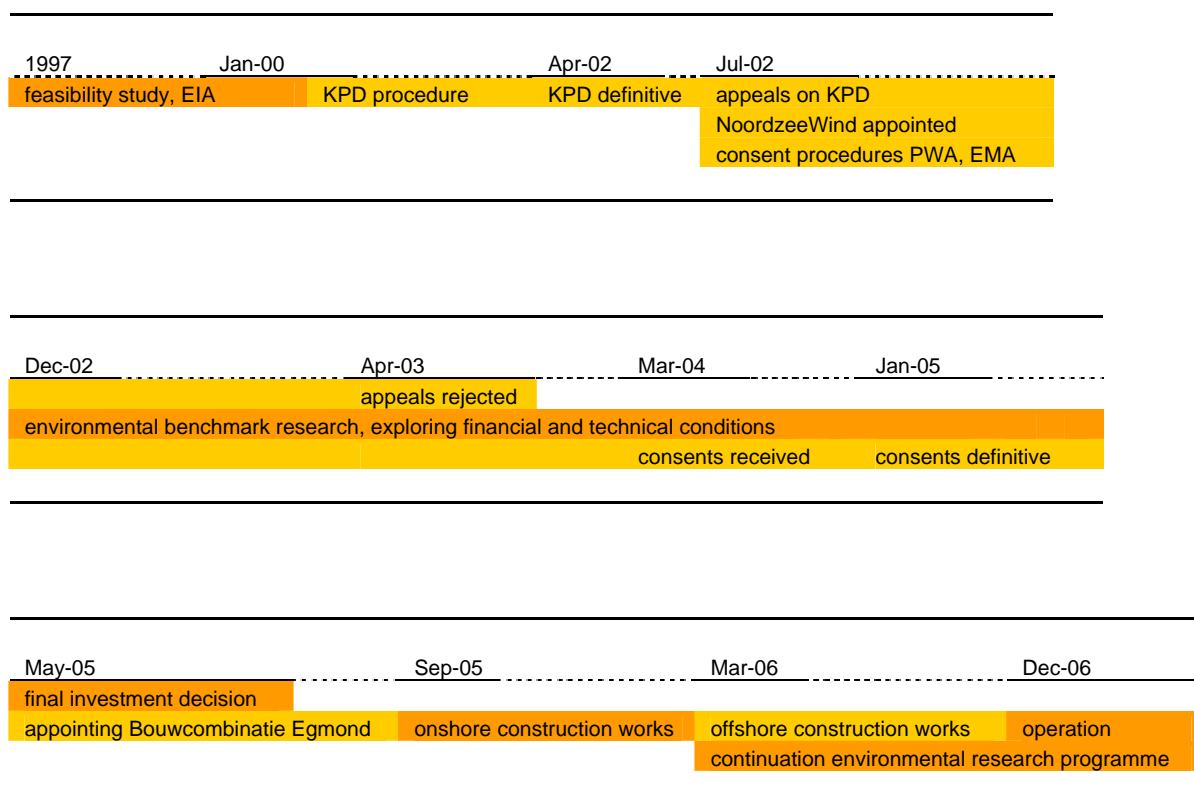

Figure 2-3: Time schedule of the OWEZ project.

## 2.2 Project planning phase

### 2.2.1 Planning, approval and communication

#### *Project management*<sup>1</sup>

In the period to July 2002, NoordzeeWind was not involved deeply in the NSW project. The joint venture came into being at the moment consent procedures were started and the research for the spatial configuration EIA commenced. To execute the EIA and handle the consent procedures and benchmark research of the Monitoring and Environmental Programme (MEP), NoordzeeWind has appointed several consultancy agencies and law firms and has co-operated closely with SenterNovem, the energy agency of the Ministry of Economic Affairs.

In May 2005, NoordzeeWind contracted Bouwcombinatie Egmond (BCE), a joint venture of Ballast Nedam Infra and Vestas. BCE is responsible for the engineering, procurement and commissioning of OWEZ. Figure 4 gives an overview of the project organisation. The parties shown in this figure are the companies officially appointed. A more complete overview is not available at the present time.

<sup>1</sup> The reader should note that topics such as internal controlling, media strategy, conflict management and subcontractors are only mentioned briefly and roughly. Given the current phase of the project, this information is either unavailable or confidential.

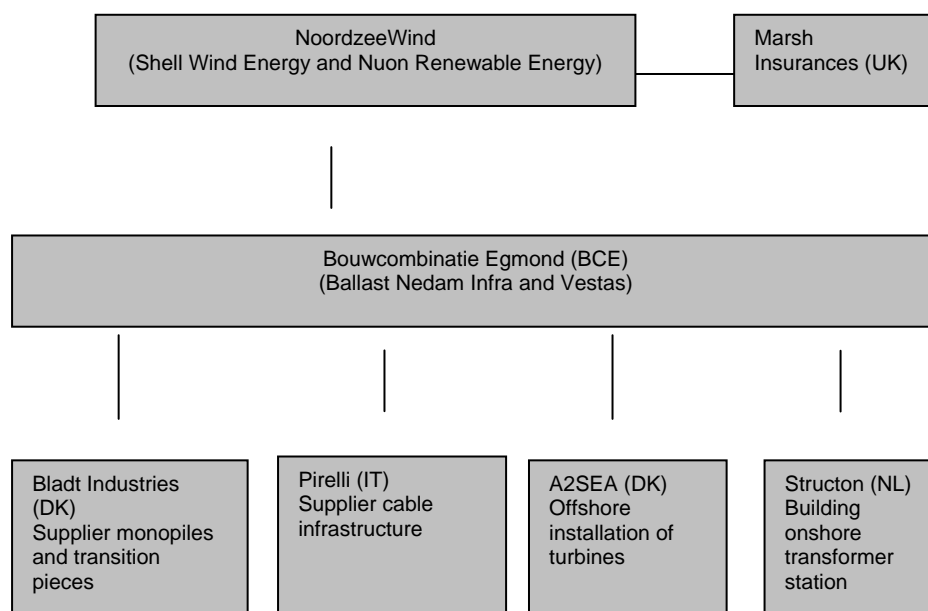

Figure 2-4: Indicative overview of OWEZ project organisation.

Given the specific nature of commissioning and developing offshore wind farms, NoordzeeWind had no real other option than to use a turnkey EPC construction. With this construction, NoordzeeWind contracted the engineering, procurement and construction of the wind farm; tasks and responsibilities that could hardly be handled by NoordzeeWind itself. Logistics, technical management and quality control not only required specific knowledge and experience, but also the capability to create an adequate project organisation. By appointing Vestas and Ballast Nedam, these capacities were secured.

### ***Planning (legislative):***

As stated above, OWEZ is a pilot project. This resulted in a strong role for several ministries in the early stages: the Ministry of Housing, Spatial Planning and Environment, the Ministry of Economic Affairs and the Ministry of Public Works, Transport and Water Management. An EIA study, conducted in 1998-2000, considered six possible locations for the first Dutch offshore wind farm. Judging by economic, environmental and technical considerations, the location of the current OWEZ was rated as most suitable. At the time, the Bird and Habitat Directives were not effective yet; nevertheless, the selected location is outside of today's restricted areas. The KPD procedure commenced subsequently and represented a considerable planning exercise and, more importantly, extensive consultation of stakeholders from governmental and non-governmental, local and national positions.

This procedure was completed in December 2003. The KPD procedure ensured that other potential usages in the area are excluded. Furthermore, the decision was embedded in spatial policies to the extent possible at that time. The Ministry of Economic Affairs invited four parties to make an offer for the proposed tender. The main reasons for selecting NoordzeeWind were its financial foundations, its proposal to develop an information centre, the quality of its research programme and the background of the parties in the consortium.

Although the next obvious step was to start a procedure to come to a Key Planning Decision (KPD), in combination with a subsequent tender procedure, this was not the sole option for the Dutch state. One potential alternative would have been what is often referred to as a "first come, first served" approach (COD 2005). This latter approach was considered to be less adequate, as it required an open market and experience with offshore wind energy for both private investors and government. These conditions were not met at the time in question. Moreover, the Dutch state preferred strong involvement in the project and conducted extensive consultations with related authorities prior to issuing consents. This was safeguarded by means of a Key Planning Decision procedure.

### Consents

Regarding their offshore activities, two consents had to be obtained by NoordzeeWind. These were based on the Public Works Act (PWA) and the Environmental Management Act (EMA). As required by the latter and recommended in the location EIA executed earlier, NoordzeeWind had to conduct a spatial configuration EIA. This EIA focussed on six specific aspects: birds, landscape, shipping and safety, fish and mammals, other usages and technology. Due to the findings in the spatial configuration EIA, several mitigating and compensating measures were taken regarding the layout of the wind farms, the depth and voltage of cables and the marking of the piles.

Table 2-1: Relevant consents and acts during the planning and preparation phase of OWEZ

	Act	Consent	Scope	Authority
<b>onshore</b>	Public Works Act	Public works consent	Crossing 1 km zone – dunes <sup>2</sup>	Directorate Public Works and Water Management North Holland
	Public Works Act	Dispensation	Dunes crossing of cables	Water Authority
	Public Works Act	Public works consent	Crossing infrastructure works	Directorate Public Works and Water Management North Holland
	Flora and Fauna Act	Dispensation	Crossing coastal zone environment	Ministry of Agriculture, Nature and Food Quality
	Environmental Management Act	Environmental consent	Transformer station	Province of North Holland
	Housing Act	Building consent	Transformer station	Municipality of Velsen
	Spatial Planning Act	Amendment of several local development plans		Municipality of Velsen
<b>offshore</b>	Public Works Act	Public works consent	Constructing, maintaining and abolishing wind farm and electricity cable	Ministry of Public Works, Transport and Water Management
	Environmental Management Act	Environmental consent	Exploiting wind farm	Ministry of Housing, Spatial Planning and Environment

As table 3 shows, consents from several different authorities had to be obtained. As a consequence of the consultation and co-operation during the KPD procedure, the different governmental bodies handled the project in line with each other. Still, from the moment the KPD was finished, it took two years before the consents were received and a further three years before they became irrevocable. However, this does not necessarily imply that the project was delayed as a consequence of these long-lasting consent procedures. The mandatory Monitoring and Evaluation Programme, for example, required several years of benchmark research before construction could actually start. So it might well be that

<sup>2</sup> This consent applies to the 1 kilometre zone. In this zone municipal and provincial regimes are still effective.

the time spent awaiting consent procedures would have been required anyway in order to meet other conditions. Furthermore, Shell and Nuon have used this time for the internal preparation of finances, technical issues and project management. These considerations question the presumption that lengthy consent procedures have delayed the project. So, although final agreements were dependant on formal procedural events or moments in time, it remains questionable whether consent procedures caused serious delays in the progress of the project.

### ***Two Environmental Impact Assessments***

Within the course of the NSW project, two Environmental Impact Assessments (EIAs) were conducted. The first was ordered by the Ministry of Economic Affairs and the Ministry of Public Works, Transport and Water Management and was finished in 2000. As described earlier, it was determinative for the location choice. The second EIA was compulsory to obtaining consents by NoordzeeWind and dealt with the spatial configuration of the wind farm. This EIA was executed by NoordzeeWind and partly by a consultancy agency.

As a result of the second EIA, the spatial configuration of OWEZ was determined (see also Figure 2), as well as technical specifications (see section 2.3) Strikingly, this EIA assumed 2,75 MW turbines and a total capacity of 99 MW. NoordzeeWind was depending on the technical state of the art at that time (June 2003). The final choice to use 3 MW was formally reported to the Ministry of Public Works, Transport and Water Management, and considered acceptable within the boundaries of previous research and consent procedures.

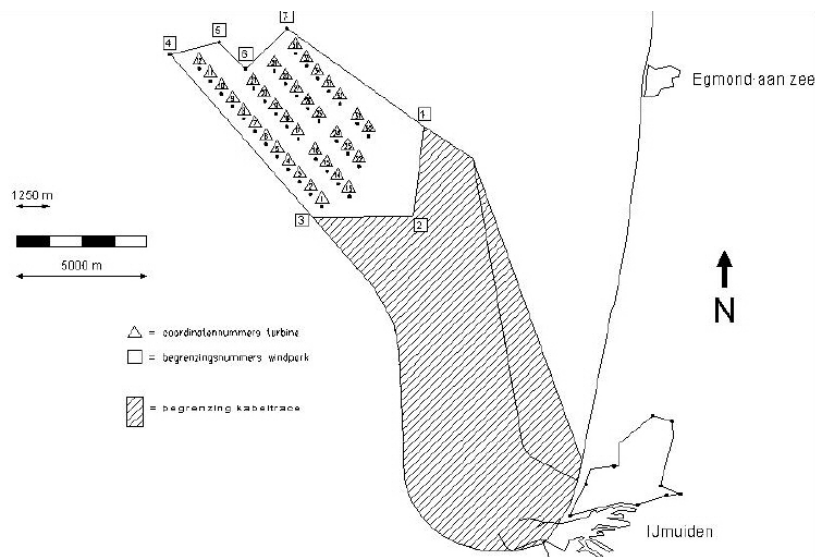

Figure 2-5: Layout and cable route of OWEZ (source: NoordzeeWind 2003a).

The configuration of OWEZ as shown in Figure 4 was determined by the spatial configuration EIA. It was based on four arguments. First, this configuration contributes to the efficient use of space. Second, visual disturbance is expected to be reduced compared to other configurations. The other two arguments related to environmental consequences of the wind farm. The estimated risk of ship collisions and the number of bird kills were considered to be at the lowest in the current configuration (Commissie MER 2003). At the same time, it was commonly understood that the number of bird kills could not be quantified yet, but was not considered to be of substantial impact.

In evaluating and assessing the spatial configuration EIA, the EIA committee made some important side remarks. Further investigation of the consequences of collisions seemed desirable. Furthermore, the cable route should allow multiple cables for future wind farms. Here, commissioning of the second offshore wind farm Q7-WP was still foreseen at the same schedule as NSW. Finally, it was recommended to include this second wind farm in the MEP research, to assess possible cumulative impacts (Commissie MER 2003). Given the uncertain situation of Q7-WP today, it remains questionable how NoordzeeWind is planning future wind farms. In any case, the cable to be installed will only serve OWEZ; there will not be any spare cable for use by future wind farms. However, the MEP can easily be extended based on other offshore experiences.

### ***Monitoring and Evaluation Programme (MEP)<sup>3</sup>***

Given the demonstration character of the project, an extensive Monitoring and Evaluation Programme (MEP) has to be executed by NoordzeeWind. Organisation and management of the MEP is done by SenterNovem, the Agency on Environment and Energy of the Ministry of Economic Affairs. The MEP is organised in 11 targets, categorised around two themes: Technology & Economy and Environment & Nature. For the latter, SenterNovem co-operates with the National Institute for Marine and Coastal Management. In the last years, the state has been responsible for the benchmark research. When OWEZ is operational, NoordzeeWind will be responsible for conducting the research programme. Although not directly linked, NoordzeeWind will be compensated for the costs of the MEP through a €27 million subsidy (see section 2.2).

The Technology & Economy theme addresses issues such as the geomorphologic influence of foundations, the predictability of energy yields, the reliability of new turbines, maintenance strategies and maritime conditions for wind installations. The Environment & Nature theme focuses on the environmental consequences of offshore farms and ways of limiting adverse impacts and risks. Several subcontractors have been appointed to execute parts of the research programme. The research data are to be delivered according to defined protocols. The findings will be classified as public, temporarily confidential and confidential. The starting point is that as much information as possible must become public, as this improves decision-making and knowledge-building (Offshore Windenergie 2005b). It is expected that NoordzeeWind will contract out the research assignments for the MEP, as it did with the benchmark investigations. This will ensure the quality of the research outcomes, as NoordzeeWind can rely on expertise and knowledge that is already available.

### ***Stakeholder involvement***

The Key Planning Decision (KPD) procedure that was followed from 2000 up to 2002 has provided many opportunities for participation by both local and provincial governments, as well as interest groups and local inhabitants. The procedure has taken into account other usages on the North Sea. In line with Dutch planning traditions, the focus of this process has been on co-operation and consensus. The interests and objections of the different parties have been brought together at an early stage. For example, environmental pressure groups have withdrawn the greater part of their objections; in exchange, NoordzeeWind will conduct the MEP and invest in the extension of nature areas elsewhere. Local environmental organisations in particular suffered from ambivalent positions. They all favour new sources of renewable energy, but still question the possible adverse impacts of offshore wind farms. Organisations like Greenpeace and WWF had already stated in an early stage that they favour offshore wind energy.

It was not until January 2005, that the final appeal was rejected by the Supreme Court. It was the Birds Society Egmond that appealed against the environmental consent that was to be issued for OWEZ. The society argued that the methods used to estimate the total number of bird losses were inaccurate and

---

<sup>3</sup> See [www.windopzee.nl](http://www.windopzee.nl) for details of the MEP.

insufficient. The Supreme Court stated that the methods being developed at the very moment will prove to be adequate. Furthermore, the Birds Society questioned the necessity of the project. Here the Supreme Court replied that this stage had passed, and that neither KPD nor current policy documents question the benefits of offshore wind energy. Again, it is uncertain whether this appeal has delayed the project significantly, given the necessary internal preparation that Shell and Nuon had to take.

Even before the KPD, Transmission System Operator (TSO) TenneT was involved in the selection of suitable onshore grid connections. In the location EIA, a suitable grid connection was incorporated in the selection of the site for the first wind farm. The choice for OWEZ to use IJmuiden harbour was confirmed in a 2004 study by the Ministry of Economic Affairs, in which Beverwijk and the Port of Rotterdam were designated as the best feasible grid connection points for future offshore wind farms (Ministry of Economic Affairs 2004). The transformation station for OWEZ will be built in Beverwijk, on the Corus site and near IJmuiden harbour. OWEZ will have its own infrastructure, however; the Corus network will not be used. As Nuon is one of the major electricity suppliers in The Netherlands, the sale of the produced electricity was handled internally.

Although the KPD procedure requires intensive participation between national and local authorities, municipalities hold a certain degree of autonomy in such complex and important spatial and economic developments (see also the section above). The municipality of Velsen was involved directly in the consent procedures, as the electricity cable will reach shore in its IJmuiden harbour. But, as can be seen in Figure 2, the wind farm is located off the shore of Egmond aan Zee (municipality of Bergen). This resulted in the peculiar situation that the municipality that expected visual hindrance was not involved in the consent procedures directly, since the formal procedures onshore only comprised the cable route. Formally, the role of Egmond aan Zee municipality was limited to participating in the environmental consent procedure, in contrast to the role of the municipality of Velsen.

Egmond aan Zee has an impressive coastal zone of high ecological value, several recreational and cultural facilities – and tourism is an important socio-economic pillar. As a consequence, possible visual hindrance was unacceptable to the municipality, or had to come with compensating and/or mitigating measures. Many of these concerns are met in a defined compensation plan.

### ***Compensation***

The original tender document of 2002 contained requirements regarding communication to be fulfilled by NoordzeeWind. The most important were an information centre and compensation for expected ecological impacts. Both were to take place in Egmond. Facing increasing costs, NoordzeeWind is discussing new communication strategies in Egmond with the municipality and concerned ministries. These strategies comprise interactive information devices on the beach and information material in the tourist information centre. Nevertheless, Egmond still aims at achieving a full-fledged visitor centre as a part of their tourism facilities. It is unclear how this will develop in future. The environmental compensation is already taking place. A significant nature conservation area near Egmond is being enlarged, commissioned by NoordzeeWind. Moreover, NoordzeeWind is involved financially in four other small-scale environmental projects.

### ***Site investigation***

Much of the site investigation has been carried out in the course of the second EIA that was done by NoordzeeWind. These investigations focussed on geographical data on the condition of the seabed. This knowledge has not so much determined the type of foundation, but the actual locations of the monopiles. The decision to use monopile constructions instead of gravity foundations was made based on a cost/benefit analysis performed earlier. The most important factor here was the depth of the sea, which would have implied massive concrete foundations. Further data on site investigation will become available at a later stage.

## 2.2.2 Economics

### *Economic and financial issues<sup>4</sup>*

The total investment for OWEZ is over €200 million. At the present time, this sum cannot be divided into different parts of the project. Sharing this information would press the current contract negotiations with subcontractors and suppliers. The same goes for information regarding the investment structure.

As followed from the original tender document of 2002, NoordzeeWind had the prospect of three types of financial support by the government. A €27 million subsidy has been awarded based on a CO<sub>2</sub> reduction scheme. This subsidy had to be permitted by the European Commission in 2005. In return, NoordzeeWind is obliged to execute the Monitoring and Evaluation Programme (MEP, see section 2.1). In addition, NoordzeeWind has to contribute to local and national information strategies. Third, a nature compensation plan is being conducted by NoordzeeWind. In addition to this subsidy, NoordzeeWind will be allowed to deduct up to 44% of its investment expenses from the taxable profits. This fiscal regulation will make investments more profitable at an early stage. Finally, feed-in tariffs have been agreed upon for the first 10 years of operation. These tariffs have been determined at 9,7 cents€ per produced kWh plus the actual electricity tariff. Confusingly, this feed-in regulation is called the MEP regulation, but is not related to the Monitoring and Evaluation Programme.

Table 2-2: Financial regulations and conditions applicable to OWEZ.

	Types of financial regulations		
	State subsidy	Feed-in tariffs	Fiscal incentive
<b>Sum</b>	27 € million.	9,7 cents€ per kWh + actual electricity tariff.	Maximum of 44% of investment costs deducted from tax- able profits.
<b>Conditions</b>	Monitoring and Evaluation Pro- gramme; nature compensation pro- gramme, information and communication activities, to be de- cided upon.	One-time contract, set for 10 years. Based on the MEP regulation of the Ministry of Eco- nomic Affairs.	Net effect unknown, as total investment sum and taxable profits are still un- known.

### **Public**

It is hard to estimate future tax payments by NoordzeeWind or the contribution of the project to local employment. Depending on the communication strategy, which has to be decided upon (see also section 2.1), a minor increase in employment could be expected. As far as the construction stage is concerned, temporary regional effects are anticipated. There does not seem to be much confidence in direct structural contributions to regional employment by OWEZ, although the presence of OWEZ can contribute to the economic profile of the region.

<sup>4</sup> The reader should be aware that the information on finances is confidential. Therefore, the content of this section should not be considered to be complete.

### 2.2.3 Technology

#### *Site organisation and selection of the technologies*

The OWEZ wind farm will comprise an area of approximately 30 km<sup>2</sup>. Surrounding cables and pipelines determine the boundaries of the site, as shown in Figure 6. The area will be closed for shipping (recreational shipping and fishing included). A 500-metre safety zone has been incorporated.

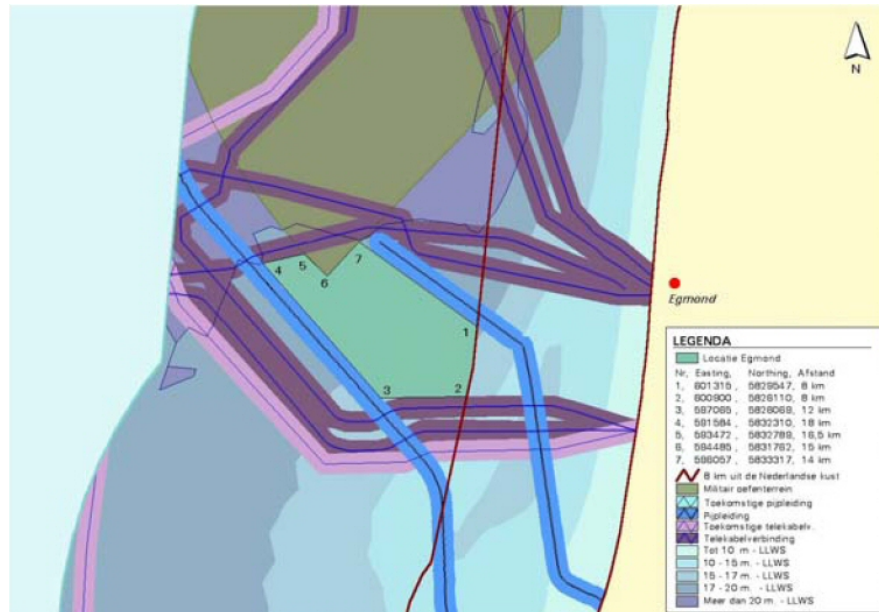

Figure 2-6: Site location and other usages (source: NoordzeeWind 2002).

OWEZ consists of 36 Vestas V90 turbines, built on steel monopile foundations. The water depth at the site varies between 15 to 20 metres. The wind farm consists of four rows at a distance of approximately 1 kilometre. Distance between the turbines will be approximately 600 metres. A 116-metre meteorological mast has already been installed, to measure wind speeds at various levels, temperature, rainfall and humidity.

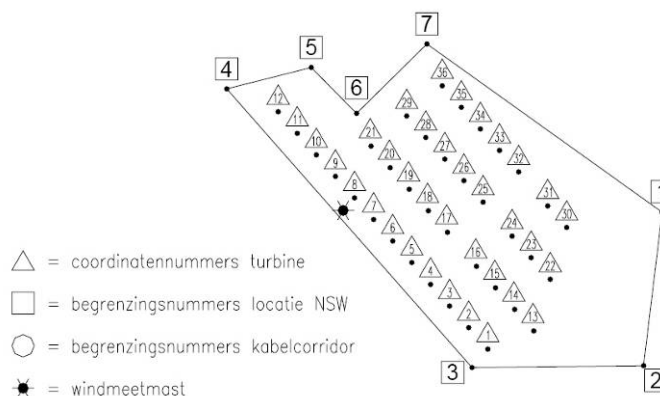

Figure 2-7: Detailed site layout (source: NoordzeeWind 2003a).

The Vestas V90 turbines will be placed on 70 metres monopiles made by Bladt Industries in Denmark. The reasons for choosing the V90 turbines are confidential at this time. The flat seabed and the considerable depths favoured the use of monopiles. This choice was made after the site investigation and a

cost/benefit analysis. The monopiles will be driven approximately 30 metres into the seabed. With an axis height of 70 metres above Mean Sea Level (MSL) and a rotor diameter of 90 metres, the maximum height will be 115 metres.

The definitive site configuration was determined by means of the spatial configuration EIA, which was mandatory in the consent procedures. NoordzeeWind has decided to locate the turbines as far to the west as possible, to reduce visual hindrance, although spatial efficiency could have been higher. The reason for this is the limited capacity that is allowed in the KPD and EIA, conducted some three years ago. In these documents, a total capacity of around 100 MW is established, with an expectation of some 50 wind turbines. Instead of determining a maximum number of turbines, a maximum capacity is determined. Given the technological progress (capacity per turbine has increased considerably), OWEZ consists of fewer turbines than expected originally. As a consequence, the site could have been used more efficiently. Therefore, it would have been more appropriate to determine a maximum number of turbines, instead of a maximum capacity, in the KPD and EIA.

### **Grid connection:**

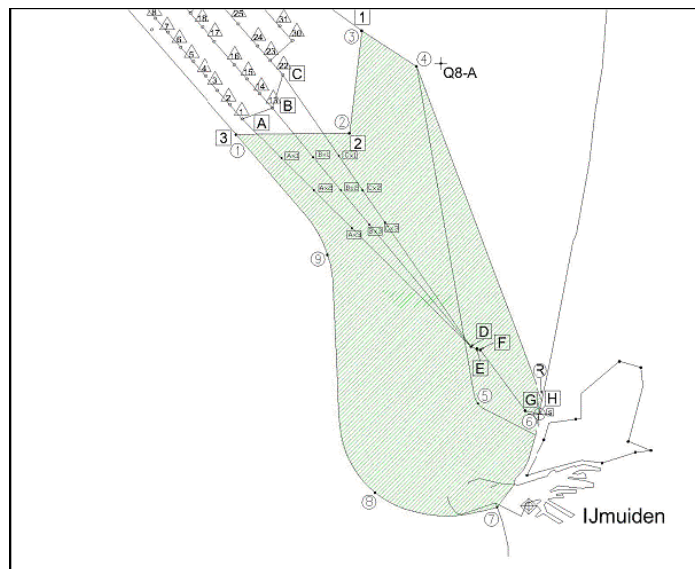

Figure 2-8: Grid connection (source: NoordzeeWind 2003a).

The 36 turbines of OWEZ will be divided in three sections of 12 each. Each 12 turbines will be interconnected as one group by means of a 34 kV sub-sea cable, buried at a depth of two to three metres. The three cables will follow a direct line to the shore, approximately 50 metres apart. Three communication lines and one gas line need to be crossed. The cables will be brought together at point D in Figure 8, approximately 3 kilometres offshore. The total length of the cables will be approximately 43 kilometres. Given the relatively short distance to shore, NoordzeeWind has decided not to build an offshore transformation station (NoordzeeWind 2003b). Instead, 34 kV cables are used and conversion to 150 kV will occur onshore in Velsen. From this substation, the local grid operator Continuon will provide a connection to the 150 kV substation in Velsen, which is connected to the national high voltage grid (Kouwenhoven 2005). This cable will have a length of another 7 kilometres.

## 2.3 Installation and operation phase<sup>5</sup>

### *Installation and grid connection:*

Commissioning and installation of OWEZ is done under the full responsibility of Bouwcombinatie Egmond (BCE). The actual execution is carried out by several subcontractors. The PWA consent has stated several regulations for site preparation, layout, safety and installation requirements. Before the actual erection can take place, NoordzeeWind is obliged to execute a site survey, in order to map the current situation and condition of the seabed. Furthermore, an action plan has to be established in accordance with all relevant authorities, including nautical safety and enforcement services. The planning and time scheme will only become available when OWEZ is operational.

### *Erection*

Originally, NoordzeeWind and BCE intended to erect, assemble and test the wind turbines on land. *Svanen*, a ship owned by Ballast Nedam, would then lift up complete wind mills and transport and install them at the foundations. *Svanen* is a heavy-lift vessel designed for the assembly of pre-fabricated bridges. It was used for the construction of the Oresund bridge, for example. See Figure 2-9 and Figure 2-10.



Figure 2-9: Svanen (source: Ballast Nedam Infra 2005).



Figure 2-10: Original installation concept (source: Ballast Nedam Infra 2005).

Due mainly to technical burdens, this erection concept is no longer considered feasible. For now, it is expected that *Svanen* will install the foundations and transition parts. The tube pole foundations will be driven into the seabed as shown in Figure 2-11. *Svanen* is currently being equipped with the necessary fixtures in the Rotterdam harbour. The transport and erection of the monopiles, turbines and rotor blades will be performed by A2SEA, a Danish company which provides services for the transportation, erection and installation of offshore wind turbines.

---

<sup>5</sup> As stated earlier, very little information on commissioning and operation is currently available.

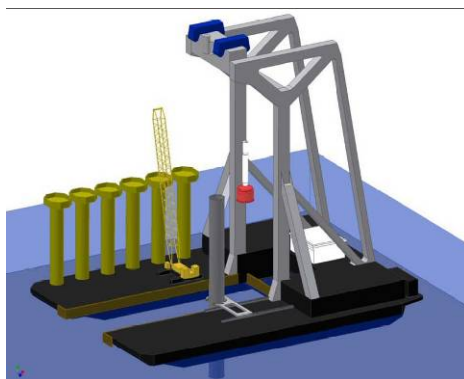

Figure 2-11: Foundation installation by Svanen (source: Ballast Nedam Infra 2005)..

### ***Logistics aspects***

The IJmuiden harbour will be used as the logistics centre. BCE project management is also accommodated in the harbour. NoordzeeWind and BCE began the site preparations towards the end of 2005. BCE has assumed responsibility for supply chain management; no further information on this is available at the present time.

### ***Grid connection***

The available details on grid connection are already stated in section 2.3. BCE has not yet appointed a cable installation contractor.

### **2.3.1 Operation**

IJmuiden harbour will be used as the service and maintenance harbour. Contrary to what is stated in earlier documents and consents, some of the turbine testing will have to be carried out offshore. Data, time schedules and project plans are not yet available.

### ***Dismantling:***

The PWA consent states that NoordzeeWind has to dismantle the offshore wind turbines after an operations period of 20 years following completion. The dismantling strategy is to be determined at a later point in time. The International Maritime Organisation (IMO) resolution of 1989 is expected to be a point of reference. After dismantling, the seabed must be restored to its original condition before the erection of the wind farm. Therefore, NoordzeeWind has already done a benchmark survey of conditions at the site. In addition, it is generally acknowledged that operations can be extended if the conditions 20 years from now are favourable.

### **2.3.2 Critical decisions**

The previous sections have provided a considerable amount of information on the Offshore Wind Farm Egmond aan Zee. In turn, this information raises several questions regarding experiences with the project. Why were certain decisions taken? What went wrong? What factors sped up the planning process and influenced the project positively? Which conditions that were originally considered ancillary turned out to be crucial? What can be learnt from the experiences so far? The major lessons of OWEZ are derived in this section. Project decisions will prove to be intertwined and interdependent.

The critical moments in the process and their consequences serve as valuable lessons for upcoming projects.

### ***Government involvement***

The Dutch government has played an important role in the progress of the NSW or OWEZ project. In addition to the decision to build a demonstration park, the location and ancillary conditions of OWEZ were determined by the co-operating ministries. Interested market partners were only permitted to join the process after site, capacity and research programmes had been determined. The KPD procedure and the first EIA encouraged intensive consultation and harmonisation amongst the relevant authorities at local, provincial and national level. Consequently, decision-making and consent procedures could be settled in a broader framework of agreement and consensus. This has been an important feature in the process, and is characteristic for Dutch infrastructure planning overall.

Although this government involvement has been a positive factor in the project, it remains questionable whether the consensus has sped up the actual project. The mandatory procedures to obtain consents were not shortened by it, as all governmental bodies hold relatively autonomous positions. At first glance, the various moments of participation and the appeal procedures that were followed seem to have obstructed the project. However, no real evidence has been discovered to confirm this impression during the research for this case study. One could argue that NoordzeeWind could have well used the time taken by the appeal procedures for internal preparations such as financing or project arrangement. The same goes for the benchmark environmental research conducted by NoordzeeWind. If this is the case, internal preparations may become the critical factor for determining the progress of a project, rather than bureaucratic procedures. Based on this research, we cannot state that administrative or bureaucratic regulations have seriously frustrated the progress of OWEZ.

One factor that subscribes to this argument is that NoordzeeWind and other private developers have indicated that they favour a leading role by the government in future projects. The fact that a location and ancillary conditions were determined and a tender procedure was followed resulted in a more stable and orderly environment for NoordzeeWind to arrive at an investment strategy. Accordingly, the experiences with OWEZ favour future use of a tender procedure instead of a 'first come, first served' principle.

The OWEZ case also shows that a tender procedure does not necessarily guarantee stable political backing. Especially with regard to finances, a stable political regime is essential. The eligibility for the 27 € million state subsidy, feed-in tariffs and the fiscal regulations have been key conditions for NoordzeeWind. The question as to which financial regulation serves best cannot be answered here; neither can we distinguish a hierarchy or preference. It seems to be more important that such regulations apply systematically: changing conditions to become eligible for financial support seems to be one of the major factors that can thwart a project's progress.

### ***Project management***

The fact that private investors in The Netherlands would favour intervention by the state in locating new wind farms and defining ancillary conditions underlines the fact that offshore wind energy still is a market in which (financial) risks are considerable. In such a situation, market participants seem to favour a more leading role by the government, to reduce uncertainties. The use of a tender system could mitigate a significant portion of these risks.

The choice to use an EPC turnkey contract reflects the preference of NoordzeeWind to transfer some of the risks and responsibilities to a third party. It also reflects the current state of the wind energy industry: various companies each hold very specific knowledge and capacities, all of which have to be incorporated in a single project. As a consequence, project management is challenging. It requires not only adequate risk assessments, but also significant project organisation and experience. Given their experience and background, Ballast Nedam and Vestas are expected to be able to handle these risks

and challenges appropriately. For the case of OWEZ, EPC contracting was the only real option for NoordzeeWind to execute the project. Depending on market developments, other project management structures (most likely multi-contracting) may be considered in future.

### ***Technologies***

The common tool to select the technologies used in OWEZ is the cost/benefit analysis. For example, the use of an onshore transformer station in combination with 34 kV cables simply turned out to be more feasible than an offshore transformer station. The distance to shore is an important factor here. The case study has shown that several decisions regarding the use of technologies, maintenance strategies and equipment are based on internal cost/benefit analyses. This implies that process management should be flexible, to a certain extent. Rapid changes in the offshore industry market also demand a flexible and adaptive project process. For example, NoordzeeWind intended to sign the EPC contract with a joint venture consisting of NEG Micon and Ballast Nedam. When Vestas took over NEG Micon, a wind turbine with a higher capacity became available for the OWEZ project. Therefore, both project management and government authorities have to be capable of dealing with a certain degree of change and flexibility.

Therefore, the decision to use certain technologies (both in the wind farms and in the commissioning phase) in OWEZ might best be described as determined by the state of technology, financial considerations and policy requirements at that particular moment. Another fine illustration of this is the allowed capacity of OWEZ. The original intention of 100 MW, stated in several formal documents, changed over the course of the project, as did the number of turbines. The wind farm that will become operational next year differs significantly from the wind farm that was foreseen three years ago, partly as a consequence of technological improvements. To some extent, governmental policy could accommodate this change. It shows that the tenability of policy statements is limited when a young, underdeveloped industry like offshore wind energy is involved. It shows that policy arrangements and the OWEZ process have allowed the project to benefit from technological innovations, possibly resulting in increased feasibility and profitability. To be able to do so, the project should be managed by both governments and developers in a flexible and adaptive manner.

### ***Other projects and future developments***

OWEZ is not the only offshore wind farm in the Dutch North Sea. Nevertheless, the project only seems to take other initiatives into account in the Monitoring and Evaluation Programme (MEP): most of the MEP results will become available for other projects. The use of shared infrastructure has only been considered briefly for OWEZ, although the fully approved Q7 wind farm is relatively close. It seems to be too early for such far-reaching co-operation or co-ordination.

This kind of co-ordination is complicated by the significant changes in wind energy policies and North Sea-related policies in recent years. The tender procedure used for OWEZ has been replaced by a 'first come, first served' principle. In 2005, this resulted in over 70 submitted proposals. In turn, the handling of these initiatives has been postponed, financial regulations are being revised and the 'first come, first served' principle is actually being reconsidered. This situation seems to be far from the desired, stable environment in which the government would allow the offshore industry to evolve naturally.

## **2.4 Lessons Learnt**

If there is one thing that characterises the Dutch OWEZ project, it is the fact that the project is a new branch of policy, surrounded by uncertainties and provisional policy arrangements. Offshore Wind Farm Egmond aan Zee is a pilot project, designed to generate knowledge, data and experience to the offshore sector. Lessons can and will be drawn from the project, providing policy-makers with infor-

mation to improve current policy instruments. Government, market and public are to benefit from the experiences gained so far, as well as those expected in the coming years.

Keeping recent experiences in The Netherlands in mind, it seems fair to state that direct governmental involvement in selecting sites for offshore wind farms and defining accompanying ancillary conditions is crucial. Market developments have revealed and underscored this need. Moreover, the KPD procedure resulted in consensus among relevant authorities. An understanding emerged between authorities and market parties creating a favourable project environment. This has proven to be one of the major benefits of the adopted approach.

In close harmony with this approach, stable and structural financial support should be available. The actual kind of support seems to be subordinate to the structural presence of it. The state of affairs with the current proposals clearly shows the impeding consequences of the absence of stable financial side-conditions.

A certain degree of flexibility in both project management and in the execution and interpretation of legal procedures has proven to be beneficial to the progress of OWEZ. This is shown clearly by the example of the stated maximum capacity of the park in the EIA documents, which was changed during the preparation stages of OWEZ. As a consequence, the capacity that will be installed is higher than that foreseen in 2002. Expected yields will be higher as well. On the other hand, the stated maximum could not prevent the inefficient utilisation of the current site. NoordzeeWind was not allowed to build more than 36 turbines (3 MW). As a consequence, the site is not exploited to its maximum: the installed capacity could have been higher within the same boundaries. Since higher yields might well reduce governmental support, it is in the interest of both developers and the government to instil a certain degree of freedom and flexibility in the decision-making process.

Environmental considerations do not seem to have put a significant burden on the OWEZ project; adverse impacts hardly excluded any options beforehand. The majority of the efforts and considerations with regard to environmental issues has not impeded the project; they were used more to examine and evaluate upcoming developments. The Monitoring and Evaluation Programme is a good example: it aims at generating necessary data to improve decision-making, not at imposing restrictions on the programme. A good explanation for this approach is the current lack of a full-fledged knowledge base for assessing the impact of offshore wind farms. And in cases where an environmental impact was projected, it has simply been compensated for. To accommodate future applications and to fully benefit from offshore potential, it seems indispensable to improve and expand current knowledge on both environmental consequences and the management of offshore wind farms.

This case study has shown that offshore wind energy in The Netherlands is a young, not-yet-mature industry to which both government and market have to adapt. It has also shown how several decisions have had a lasting impact on the project's progress, both positively and negatively. Some of these were critical, in that they played a major role in determining future possibilities. Others were no more than 'topics to be decided upon' and did not redirect or affect the project significantly. The case study has also shown that strong involvement by the government can contribute significantly to the realisation of an offshore wind farm. Offshore Wind Farm Egmond aan Zee has taken advantage of the attitude and policies of the involved Dutch ministries. Likewise, the Dutch government will benefit from the experiences with OWEZ. This case study research has hinted at the benefits of a tender system for the coming years. It remains to be seen whether this will eventually be realised.

### 3 Thornton Bank (Belgium)

#### 3.1 General

##### 3.1.1 Project description

Thornton Bank is the first offshore wind farm project to be realised in Belgium. The site selection and project proposal was done by a private company, C-Power, and not by the government. C-Power is a joint enterprise, set up by the various private Belgian companies listed in Table 3-1, to develop, install and operate the wind farm.

The proposal was accepted by the government and was promoted to demonstrate offshore wind energy utilisation in Belgium. The originally planned location was close to the coastline. Due to environmental concerns, the government decided to shift the wind farm area further out into the sea and to designate an area specifically for offshore wind farms. The Thornton Bank project lies within this area.

The increased distance to shore had a severe impact on the economic viability of the project, and thus the government agreed to improve the situation by subsidising the grid connection by 30% and rendering guarantees for the energy sales price.

The separation into different project phases was also influenced by governmental request, a pilot phase was requested in order to analyse the impact of the wind farm on the environment.

Table 3-1: General description of Offshore Wind Farm Thornton Bank<sup>6</sup>.

Project description Thornton Bank	
Project name	C-Power farshore wind farm on the Thornton Bank
Country / region	North Sea, Belgium
Owner / Investor	C-Power NV, Scheldedijk 30, 2070 Zwijndrecht, Belgium
Developer	C-Power NV, Consortium of four Belgian companies: <ul style="list-style-type: none"> <li>• Interelectra</li> <li>• Ecotech Finance</li> <li>• Socofe</li> <li>• Dredging International</li> </ul> and one French company <ul style="list-style-type: none"> <li>• SIIF Energies</li> </ul>
Operator	C-Power NV
Location, geographical position	27– 30 km to Belgian Coast
Area	13,79 km <sup>2</sup> : section A=4,99 km <sup>2</sup> ; section B=8,80 km <sup>2</sup>
Water depth	10 – 24 m
Distance to shore	27 – 30 km
Operators website	<a href="http://www.c-power.be">http://www.c-power.be</a>

<sup>6</sup> Information by private communication and from [www.c-power.be](http://www.c-power.be)

### 3.1.2 Technical data

The Thornton Bank offshore wind farm is planned to be build in three phases, with only a small number of turbines (six) in the pilot phase and a final expansion to 60 turbines in 2010.

The size of the turbines has not been determined yet; the selection of manufacturer and turbine rating depends on the suitable technologies available during project realisation. A building permit has been requested for 60 wind turbines with an installed capacity of between 3.6 MW and 5 MW.

Table 3-2: Technical Data of Offshore Wind Farm Thornton Bank.

Technical data Thornton Bank	
Total MW	Pilot phase 21,6 MW First expansion phase 120 MW in total Final phase 300 MW in total
Number of Turbines	6 in demonstration phase (2006/2007), 24 in first expansion phase (2009) and 60 in final phase (2010)
Turbine manufacturer and rating	3,6 MW to 5 MW
Hub height	80 or 85 m above sea level
Rotor diameter	100 – 120

The planned wind farm lies in an area designated by the government for offshore wind farm installation (see Figure 3-1). The area lies outside the 12-nmi zone, south of the main sea traffic routes and north of the traffic routes to Belgian harbours. The wind farm is split up into two sub-areas (see Figure 3-2), with a 6 x 6 and a 4 x 6 WTG installation geometry. The wind farm area lies on a sand bank, the Thornton Bank, which is surrounded by other sand banks.

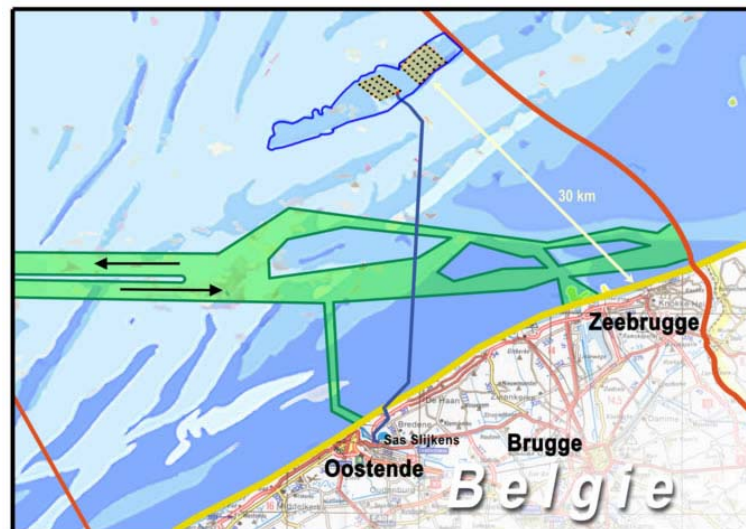

Figure 3-1: Geographical location of the wind farm Thornton Bank.

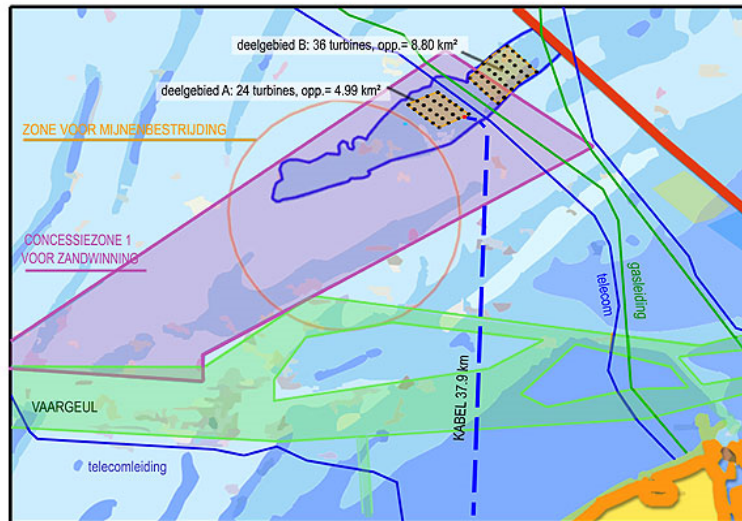

Figure 3-2: Closer look at the wind farm area.

### 3.1.3 Time frame

The project schedule was delayed by one year due to problems in setting up the financing scheme. At the present time, all permits have been obtained and the economic viability is given. As depicted in Table 3-3, the demonstration phase will run from 2006 to 2007, with the construction of six turbines as well as the first wind-measuring mast and the first electricity cable. The second phase, with the construction of 18 turbines and the offshore transformer station, will run in 2008 – 2009. The final construction phase, with 36 turbines, will be done in 2010, along with the installation of the second wind-measuring mast and second electricity cable.

Table 3-3: Time schedule for Thornton Bank.

Time schedule	
Submission of application	August 2002
Approvals	All permits received by 2005
Planning phases, time schedule	
Installation start of the pilot phase, 6 WTGs, 1 <sup>st</sup> wind measurement mast and 1 <sup>st</sup> 150 kV-sea cable	2006/2007
Start of operation of the pilot phase	2007
Installation of second phase, construction of 18 turbines and the offshore transformer station	2008 – 2009
Installation of final phase, construction of 36 turbines, 2nd wind measuring mast, 2nd electricity cable: 150 kV (40 km)	2010

Currently all permits required for the offshore installation process have been received. The engineering for the offshore foundations is in progress. The business plan has been approved by the financing bank and the company is ready to start the investment. The manufacturing is planned to start in the second half of 2006 and the contracts are under negotiation. The turbines for the first phase should be ready installed and start operation in 2007.

Decisions for three contracts are in progress, for:

- foundation
- supply and erection of turbines
- electrical infrastructure.

## 3.2 Project planning phase

### 3.2.1 Planning, approval and communication

#### ***Project management:***

The Thornton Bank project was initiated by five companies (see Table 3-1). These five companies formed C-Power, a private company, to take over the complete project management and development, as well as subsequent ownership and operation of the wind farm.

#### ***Planning (legislative) and approval:***

The first wind farms in Belgian waters were planned close to the coast. The government decided to designate an area specifically for offshore wind energy utilisation. Due to environmental concerns, this area was shifted 30 km out to sea. The government designated a concession area and launched a tender for offshore wind farm operation. C-Power was the only remaining consortium out of the eight companies which submitted project proposals for the development of a large-scale offshore wind farm in the North Sea. The application was made for two separate wind farm sites, as described in the previous section.

The application for the offshore wind farm building permit and operating license had to be made to the Federal Minister responsible for the Marine Environment. The guidelines of the 'Royal Decree of 7th September 2003' had to be followed.

A big advantage for the approval process in Belgium is the "one-stop office approach". The applying party only had to communicate with one office, even though different ministries and offices had to approve the various project applications. This office was responsible for the complete approval process and had to manage and arrange the application process with all legal bodies affected. In addition, the office was also responsible for the onshore and offshore approval inside and outside the 12-nmi zone.

The project application was submitted in August 2002. The commission for regulation from electricity and gas (CREG) gave its consent in April 2003. In June 2003, the Federale Overheidsdienst Economie, the K.M.O., Middenstand En Energie and a ministerial decision awarded a domain license (domeinconcessie) to N.V. C-Power – for the installation of the Thornton Bank offshore wind farm and for the exploitation of its electricity production.

#### ***Approval procedure for offshore cable:***

The approval for the sea cable route had to be granted by the Federal Minister for Energy, under consideration of the "Royal Decree of 12 March 2002". The submission was made in October 2003 and permission was obtained in February 2004. The permit for the 150 kV–sea cable between the offshore transformer platform and the public 150 kV electricity grid on the mainland stipulates that the cable must be buried in the seabed.

The Federale Overheidsdienst Economie, K.M.O., Middenstand En Energie and a ministerial decision of 13 February 2004 awarded a license for the installation of two electricity cables of 150 kV to N.V.

C-Power, to connect the wind farm transformer station to the utility grid, as well as for electricity cables of 36 kV for the internal wind farm interconnection.

***Approval procedure for onshore cable:***

The onshore cable, which connects the landing point of the offshore cable with the utility grid, also required approval by the Federal Minister responsible for Energy (road license) and by the Ministry of the Flemish Community, Town and Country Planning Administration, Housing and Monuments and Landscapes (AROHM) – under consideration of the “Royal Decree of 26 November 1973 “ and the “Decree of 18 May 1999 “. The submission was made in October 2003 and permissions were received in March 2004.

The onshore cable has a total length of 3,8 km and is planned and approved entirely as an underground cable.

***Approval procedure for grid connection:***

To connect the offshore wind farm to the utility grid, the technical and financial terms and conditions of the network connection had to be agreed upon with ELIA, the network operator. The capacity of the high-voltage overhead line to which the wind farm will be connected is sufficient to pick up the 300 MW installed power of the turbines.

Two studies were performed, at the end of 2002 and in the summer of 2004, to analyse the available capacity-related and technical issues of the grid connection. Based on the outcomes of these analyses, an agreement with the network operator was reached and the order for grid connection was placed in September 2003. The works began in April 2004.

***Embedding in spatial planning:***

The original planning of the offshore wind farm involved building the plant near the coast. The decision to designate an area for offshore wind energy utilisation was then taken by the Belgian government. Based on environmental considerations, this area was shifted further out into the sea, to Thornton Bank, the next sand bank.

A concession area was designated. The government launched a tender for the wind farm installation, C-Power ultimately won.

***Environmental impact assessment:***

The basic requirement for the offshore wind farm building permit and operation license is the EIA. The EIA includes site investigations by vessels, for example, to count birds, fish, etc. The initial monitoring run was scheduled from October 2003 to 2005. During this 2-year programme, the zero-situation had to be recorded, in order to determine the site conditions before any installation and operation activities began.

Later, the installation period has to be covered by a second monitoring programme, to investigate the impact of the installation works on avifauna and the marine environment. After operations commence, the offshore wind farm will be monitored by a governmental agency during its entire lifetime, paid for by the wind farm operators.

***Stakeholder involvement:***

The stakeholder involvement was performed in the usual way for large building approvals. Within a time period of 60 days, interested parties could submit their concerns or comments to the responsible department in the Federal Ministry for the Marine Environment.

**Media strategy**

In addition to the publications made in the approval process, C-Power operates a Web site<sup>7</sup>, which presents comprehensive information and documents about the project, the application and approval procedures, construction and technical issues, environmental impact assessment, time frame etc.

The public was further informed by press conferences and press articles (a list of papers is published in the newsletter on the C-Power homepage) and interviews in television and radio news, as well as in political debates. In the coastal region, public information campaigns were also performed.

The main messages of these events were information regarding

- how the European target for renewable energy can be met
- Belgium's aim of generating 6% of its electricity from renewable energy sources by 2010 to fulfil its Kyoto obligation
- that wind energy is capable of making the most economic and realistic contribution at present

In addition, C-Power also described how their initiative to build an offshore wind farm in Belgian coastal waters fits into the context of these European and Belgian commitments. The C-Power project on Thornton Bank represents one-third of the total outstanding Belgian obligation, still to be realised by 2010.

The public presentations helped to keep the level of public acceptance very high and had a positive effect on the opinions of policy makers as well.

**Site investigation:****Geological investigation**

In 2004 an intensive soil investigation campaign was performed, which led to adjustments concerning the design and budgeting. The soil investigation is the basic investigation for selecting the foundation type and design. Accordingly, the results can have a drastic impact on the economic feasibility of the project.

In April 2004 C-Power started with a soil investigation for the first phase of the wind farm installation, which concentrated on the locations of the first six wind turbines. In addition, detailed soil investigations were also performed for the entire cable route, from the wind farm to shore.

Three ships were used to perform these investigations: the Coastal Surveyor 2, the Vagant Jack-up platform and the Multiship Commander with Side Scan Sonar

---

<sup>7</sup> [www.c-power.be](http://www.c-power.be)



Figure 3-3: Multiraship Commander, used for site scanning with Sonar<sup>8</sup>.



Figure 3-4: Vagant Jack-up platform used for soil investigations.

### ***Wind speed measurements***

Also in 2004 a measurement met mast was set –up, to determine the wind conditions at the project site.

### **3.2.2 Economics**

#### ***Economic and financial issues:***

The economic viability of an off-shore wind energy project strongly depends on the geographical and geophysical conditions: distance to shore, water depth and soil conditions. For the Thornton Bank project, the shift of the wind farm further into sea had a negative impact on the project economics.

The result of sea ground investiga-

tions, as well as the later decision of the government to shift the project further into sea, led to a decrease in economic viability. The costs for foundations and for grid connection rose severely. As a reaction to the worsened economic situation, the government decided both to increase the value of green certificates and to support the grid connection financially.

The government requirement to install a first pilot phase with a limited number of turbines had also a negative effect on the grid connection cost. The cable, which is laid in the first phase, will have the capacity to transport the energy from 30 wind turbines, which means it will be sufficient for the first and second project phases. For the pilot phase, however, this means economic viability is not achieved

<sup>8</sup> [www.ship-photo.de](http://www.ship-photo.de) and members.lycos.nl

without the state subsidies for the grid connection. The costs of the cable connection amount to 20% of the total project cost and more than 35% of the total cost of the pilot phase. The costs, which are depicted in Table 3-4, show the large difference in specific costs (€/kW) between the pilot phase and the final phase, which results from the high grid connection cost and low installed wind farm capacity for the pilot phase.

Table 3-4: Economic figures for Thornton Bank.

<b>Economic figures</b>	
Investment costs	
pilot phase	100 mil.€
final phase	500 mil.€
Specific investment costs	
pilot phase	4630 €/kW
final phase	1667 €/kW
Subsidies for grid connection	33 % grid cost, maximum 25 mil.€
Specific investment costs considering subsidies	
pilot phase	3472 €/kW
final phase	1583 €/kW
Feed-in tariff	10,7 ct€/kWh + actual feed-in tariff

As the costs for the grid connection for the relatively small wind farm from the first phase were rather high (and in fact were the main impediment to project realisation), the board of ministers decided to co-finance 1/3 of the cable costs with a maximum of 25 million €, with the sum to be distributed over five years

In addition, a higher value for green certificates could be negotiated, to compensate for the higher costs imposed by the increased distance to shore. A value of 107 EUR/MWh was set by the government for the entire project lifetime of 20 years. The green certificate reimbursement is paid on top of the feed-in tariff for energy production. As the wind farm has to participate in the electricity market, the price will vary severely. The participation in the energy market requires a forecast of energy production for the next 24 hours. As the variation in the energy forecasted will be larger than for conventional power plants, a balancing range of 30 % is allowed for the Thornton Bank project, instead of the usual 10 % for conventional power generation.

The distribution of the different project costs is depicted in relation to the total costs, separately for phase 1 and phase 2, in Figure 3-5. The share of the turbine cost, which is exceeded largely by ancillary costs such as grid connection (including ELIA, the utilities, subsidy) and development costs in phase 1 become nearly half of the total costs for phase 2, while the ancillary costs become relatively smaller. We therefore see that the costs per installed MW for wind power will decrease rapidly with a growing project size.

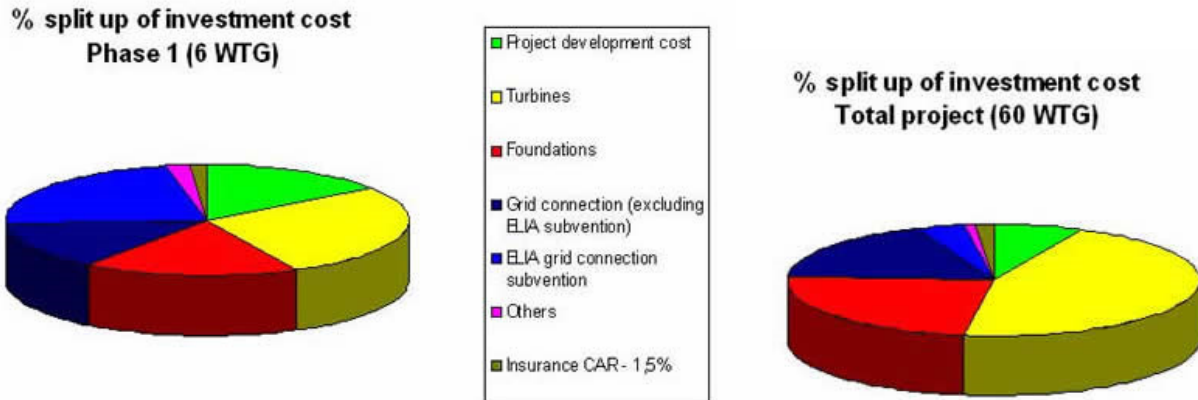

Figure 3-5: Distribution of project costs for phase 1 and phase 2.

### 3.2.3 Technology

#### ***Selection of the technologies:***

C-Power applied for and received permission to install 60 wind turbines with a capacity of 3.6 MW minimum to 5 MW maximum. The technology and type of turbine is still unclear.

The consulting company Wint was assigned by C-Power to prepare a study to examine the feasibility of different foundation types for the Thornton Bank location. This preliminary study mainly focussed on the economic and technical analysis of monopile and gravity foundations. The soil investigations carried out at the Thornton Bank location finally led to the decision that only gravity would be technically viable; even so, the costs of this foundation are high due to the water depth at the location.

The spacing of the turbines is selected to be five to seven times the rotor diameter.

#### ***Grid connection:***

The transmission technology chosen for the Thornton Bank wind farm will be HVAC on a 150 kV voltage level. The grid connection – consisting of the three partitions internal cabling, sea to shore and onshore cable – will have the following data:

- The internal cabling between the single turbines and the offshore transformer station will be realised by 36 kV submarine cables with a total length of 50,75km, see Figure 3-6.
- The connection between the offshore transformer station and the onshore landing point will be done by 3-phase 150kV submarine cables with a length of 35,95 km each, see Figure 3-8.
- The further connection from the landing point to the 150 kV high-voltage grid at Slijkens in Bre-dene will be realised by six mono-phase underground land cables with a length of 3,3 km each, see Figure 3-9.

The installed grid connection line will be underground sea and land cable. The cable landing will be performed by a horizontal drilling underneath the coastal sand dunes; see Figure 3-7. A tunnel will be drilled offshore from a jack-up platform towards the onshore landing point, inland of the sand dunes. The sea cable will be drawn through the tunnel from land.

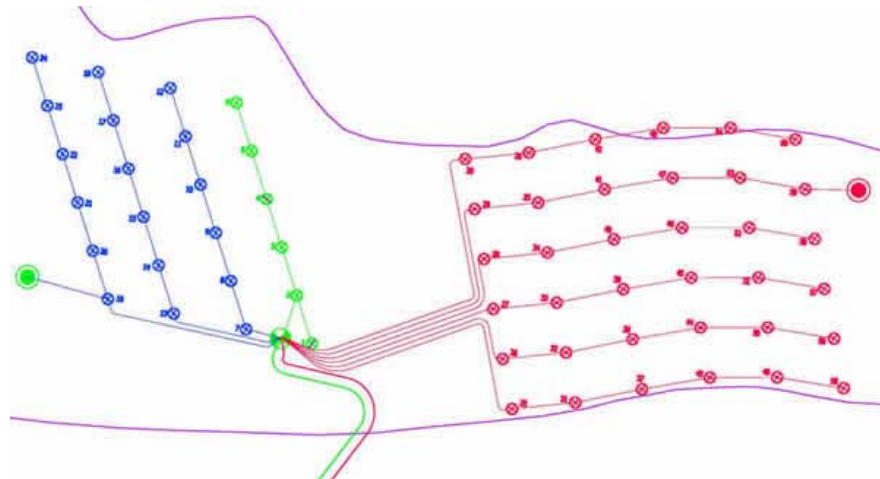
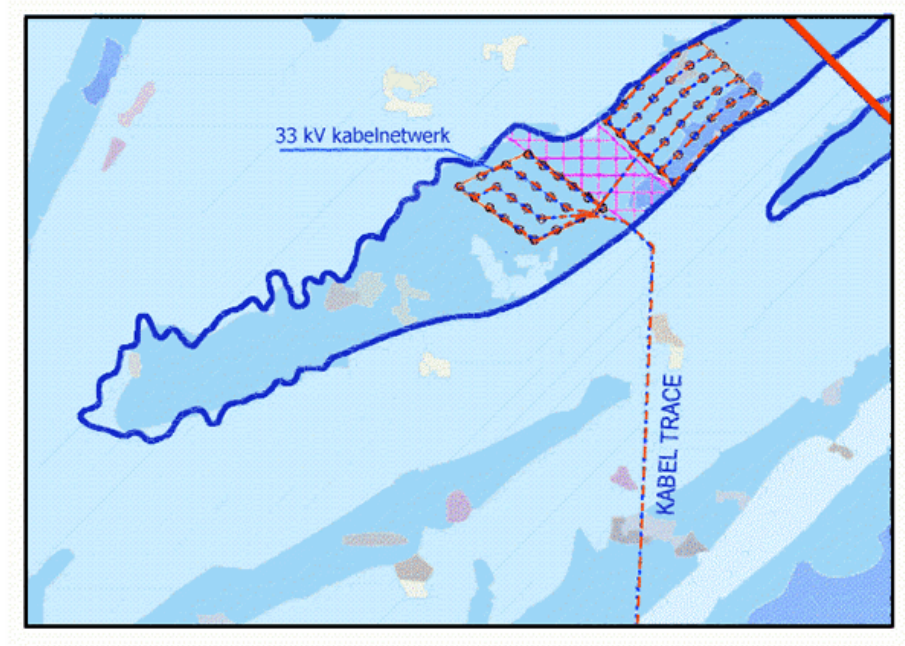

Figure 3-6: Inter-array cabling in the wind farm. The wind turbines are connected via a 30 kV sea cable to the offshore transformer station.

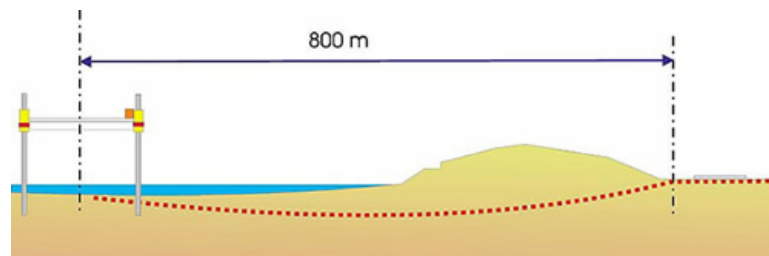

Figure 3-7: The cable landing will be done by a vertical drilling below the sand dunes at the sea coast.

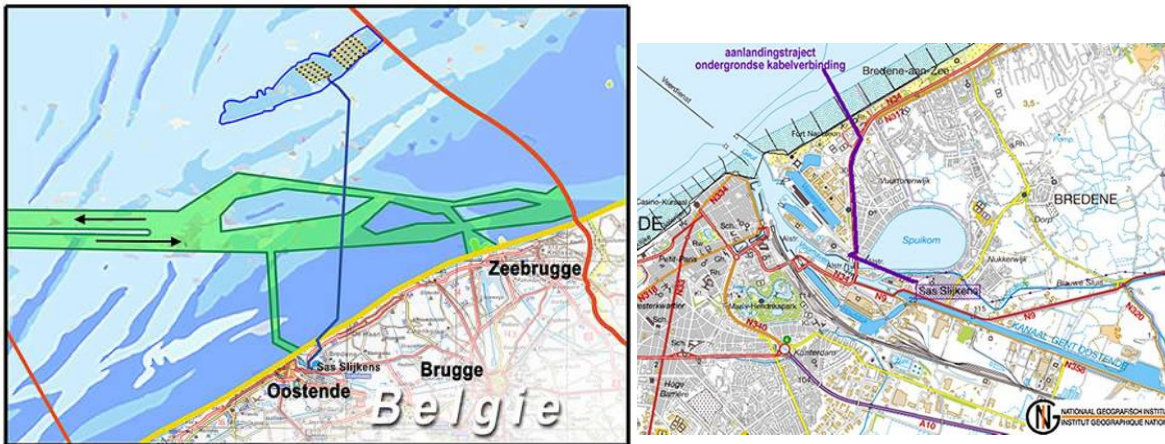

Figure 3-8: The route of the sea cable from the offshore wind farm to land (left) and from the landing point to the onshore substation (right).



Figure 3-9: The grid connection point at the high voltage (150kV) substation at Slijkens in Bredene, Oostende.

### 3.3 Installation and operation phase

The C-Power consortium is managing the complete procurement and installation process. The orders will be placed in a multi-contractual procedure only for one part of the installation works; the other part will be covered by partners already in the consortium. Tenders will be requested for cable delivery and laying and for turbine procurement and installation.

During the installation process, detailed environmental monitoring process is required: 5 persons will work on this continuously. Monitoring will be performed by a government agency over the facility's full operational lifetime; the investigations will be financed by C-Power.

### 3.4 Lessons learnt

Three issues had a large impact on the viability of the Thornton Bank offshore wind farm project. The decision of the government to shift the wind farm area further out to sea led to increased costs for the grid connection, as did the decision to request a pilot phase with a small number of turbines. The third impeding issue was the lack of information on the soil conditions at the Thornton Bank. Earlier site

investigations could have revealed the need to use more expensive foundations at an earlier stage, but these higher expenses could not have been avoided due to the governmental decision to locate the wind farm where it did. This unfavourable situation was the result of a lack of experience with off-shore wind farms and could not be foreseen. The financial adjustments by the government helped to rectify this situation.

Thus the major lesson learnt for C-Power is to conduct the site investigation at an early stage and to follow a complete investigation program in order to obtain as much soil data as possible, as a basis for the further engineering.

## 4 Borkum West (Germany)

### 4.1 General

#### 4.1.1 Project description

Borkum West was the first offshore wind farm projects began in Germany. The initiators, the PROKON Nord Energiesysteme GmbH, tried to find a location without competing utilisation or nature preserve conflicts. The result was an area between the two main traffic routes in the German Bight. The Borkum West project was designed with a comparatively small pilot phase, consisting of 12 turbines of 5 MW each. Borkum West was the first offshore wind farm in Germany to receive a building permit by the Bundesamt für Seeschifffahrt und Hydrographie (BSH), the Federal Maritime and Hydrographic Agency. Due to problems in gaining approval for the grid connection sea cable, the project was delayed considerably.

Looking at the current situation in Germany, where the overall process of offshore wind farm installation is stalled by grid connection and financing issues, the Federal Ministry for Environment (Bundesministerium für Umwelt, Naturschutz und Reaktorsicherheit = BMU) decided to support the construction of the first offshore wind farm in Germany by establishing a test wind farm project. The supporting measure was to buy the planning, approval and utilisation rights of the pilot phase of the wind farm from the developer, Prokon Nord, and offer the wind farm to potential offshore wind farm developers or manufacturers. The wind farm rights of the pilot phase were transferred to a newly established foundation “Stiftung der deutschen Wirtschaft für die Nutzung und Erforschung der Windenergie auf See (Offshore-Stiftung)” with the task of managing the installation of the first German offshore wind farm. The major wind farm is still owned and developed by Prokon Nord.

Table 4-1: General description of Offshore Wind Farm Borkum West

Project description Borkum West	
Project name	Borkum West
Country / region	Germany, Lower Saxony
Owner / Investor	Prokon Nord Energiesysteme GmbH
Developer	Prokon Nord Energiesysteme GmbH
Operator	Prokon Nord Energiesysteme GmbH
Location, geographical position	The planned site is located approximately 45 km north of the island of Borkum outside the 12 sea mile zone within the Exclusive Economic Zone of Germany, in between the ship traffic disjunction area
Area	
Water depth	30 m
Distance to shore (km)	45 km
Operators website	<a href="http://www.prokonnord.de">www.prokonnord.de</a>

#### 4.1.2 Technical data

The Borkum West offshore wind farm was planned to be built in two phases: a pilot phase with only 12 wind turbines and a second extension phase involving an additional 196 turbines (see Table 4-2). The technical data of the project will change in the future. Due to the changed ownership, the current situation is, that turbines will be installed and operated by three different companies, a group of four turbines by each party. As it is planned that these companies shall be the three wind turbine manufacturers with 5 MW offshore-turbine technology, different technologies will be installed in each of the three turbine groups. The electrical infrastructure shall be used corporately by the single wind farm operators and will be installed and operated by a separate infrastructure company.

Table 4-2: Technical data of Borkum West Offshore Wind Farm.

Technical Data Borkum West	
Total	Pilot phase 60 MW Extension phase 1000 MW
Number of Turbines	Pilot phase 12 Extension phase 208
Turbine manufacturer and Wind farm capacity	Originally planned Multibrüd, 5 MW Now probably 3 different types of 5 MW turbines
Expected annual output	Pilot phase 260 GWh/a Extension phase 4300 GWh/a
Hub height	approx. 90 m
Rotor diameter	minimum 116 m

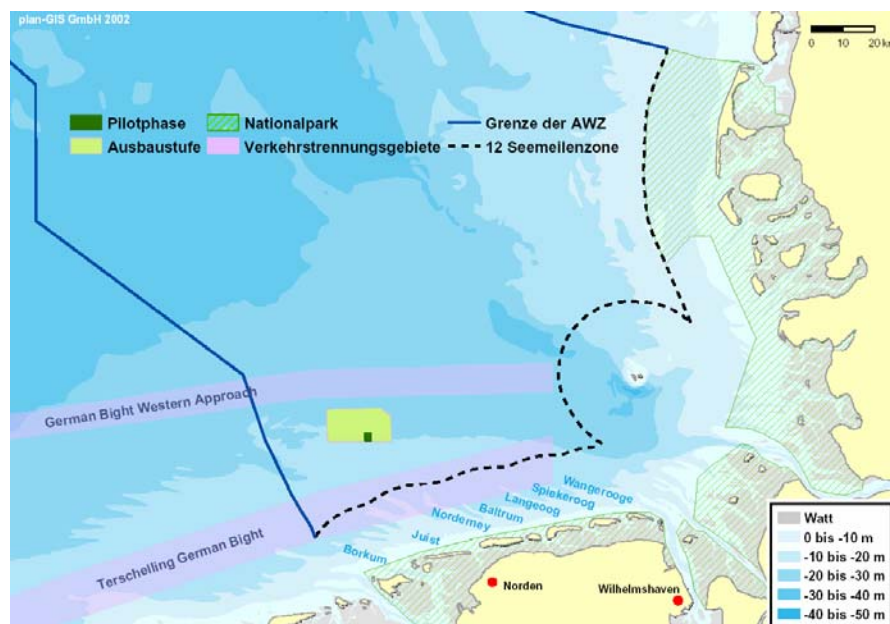

Figure 4-1: The wind farm area is planned outside the 12 sea mile zone within the exclusive economic zone (Ausschließliche Wirtschaftszone = AWZ) of Germany. The area lies between the two important traffic separation zones. In the pilot phase only 60 MW are planned to be installed, in the completion phase a total of 1000 MW.

### 4.1.3 Time frame

Initial pre-planning of the Borkum West wind farm began in 1998. Official project planning started in 1999. Due to various delays in getting the necessary consents for the grid connection for the offshore wind farm, the first one applied for in Germany, the time schedule had to be rearranged. The current time schedule is depicted in Table 4-3.

The developer, Prokon Nord, began early to set up an investigation programme to cover all items of an EIA. In September 1999 Prokon Nord submitted the first formal application for a building permit in the EEZ to the responsible agency, Bundesamt für Seeschifffahrt und Hydrographie (BSH), the Federal Maritime and Hydrographic Agency.

Table 4-3: Current schedule of the Borkum West project<sup>9</sup>.

Time	
In 1998	Start of pre-planning
In 1999	Start of planning phase
September 2000	Start of the investigation programme
In 2003	Originally planned start of operation
May - October 2006	Start of building phase concerning cable routes, accompanying monitoring process Erection of foundations and wind turbines of the pilot phase Accompanying monitoring of the building phase
until May 2008 / 2009	Accompanying monitoring of the operational phase
2008 / 2009	Planned start of establishment of the extension phase
2011 / 2012	Offshore Wind farm "Borkum-West" is finalised

On 16 May 2000, the first application hearing at the BSH was held in Hamburg, together with all interested stakeholders and public agencies. At this hearing, the investigation programme for the EIA investigations was defined.

This investigation programme for the EIA started in September 2000 with a detailed site screening programme. In April and October 2001, the results of a pre-investigation by Germanischer Lloyd, a risk analysis concerning ship safety, were presented to the BSH. Partial approval was granted in July 2001, based on the documents submitted so far.

With the results from the previous investigation programme, the building permit for the wind farm was granted by BSH on 9 November 2001. Borkum West was the first offshore wind farm in Germany to receive a building permit from the BSH and the first offshore wind farm world-wide to receive a wind farm building permit in the exclusive economic zone of a coastal state. Prokon Nord intended to build the wind farm in 2003.

Nearly in parallel to the wind farm approval process, an application was made to the regional administrative board for the 12-nmi-zone, the Bezirksregierung Weser-Ems, as well as to BSH, regarding the grid connection. The approval process for the sea cable through the 12-nmi zone turned out to be

<sup>9</sup> Information gathered from [www.prokonnord.de](http://www.prokonnord.de)

rather complicated, leading to the current situation: the cable should be laid only in co-ordination with other projects. As this co-ordination is quite complex with respect to the technical and financial demands, the cable laying will be delayed until the process is complete.

The application hearing for the sea cable route through the EEZ was held on 20 February 2001. The approval for the sea cable through the 12 - nmi-zone was granted by the Bezirksregierung Weser-Ems on 30 April 2002, the approval for the EEZ was granted by BSH on 15 December 2004.

## 4.2 Project planning phase

### 4.2.1 Planning, approval and communication

The initiators tried to find a location without competing utilisation or nature preserve conflicts. The result was an area between the two traffic separation zones in the German Bight, taking into account the following main precautions:

- keeping a sufficient distance to both ship traffic routes, to minimize the risk of ship collisions
- no avifaunistic or otherwise biologically specifically important area
- location north of the 54<sup>th</sup> degree of latitude to avoid conflicts with local fishermen
- large distance to the East Frisian islands, to avoid interference with tourism concerns.

#### *Planning (legislative):*

#### *Types of approvals needed:*

The permissions required to build the offshore wind farm and to lay a sea cable are listed in Table 4-4. As the wind farm area lies in the EEZ, permission to install the wind farm is required from the BSH. Several permits are also required for the laying of the sea cable: one permit to lay the cable in the EEZ and another permit to lay the cable in the 12 - nmi zone. As the cable will cross shipping routes and tideways, a permit is required from shipping authorities, as well as for the “land lease” of the seabed in the 12 - nmi zone. Down the path, a permit to cross dikes and small waters has to be obtained from regional authorities, as well as for the crossing of the National Park area.

The main expertises requested by the approval procedure were:

- Environmental Impact Assessment (EIA): at least two years of investigations of benthos, fish, sea mammals, birds, biotope mapping, data assessment, Fauna-Flora-Habitat (FFH) impact assessment.
- Ship collision risk analysis
- Development of temperature profiles in the seabed around sea cables
- Scan of sea floor to investigate the suitability of the sea bottom for wind farm installations.

Table 4-4: Required permissions for the sea cable

Approval	Responsible Authority
Building permission for the pilot phase	BSH
Permission for laying and operating the cable in the seabed by the authorising agency for river- and navigation-specific police approval	Wasser und Schifffahrtsverwaltung des Bundes (Federal Water and Shipping Authority)
Lease contract to use the 12-nmi zone for laying a sea cable	Wasser und Schifffahrtsverwaltung des Bundes (Federal Water and Shipping Authority)
Water and Dike Permission, approval to cross dikes and waters	Bezirksregierung Weser-Ems (Regional Administrative Board)
Exemption from the prohibitions of the National Park	Bezirksregierung Weser-Ems (Regional Administrative Board)
Permission for laying the sea cable in the EEZ	BSH
Consent for grid connection	E.On Netz GmbH (network operator)

#### ***Approval procedure for wind farm site:***

Approvals for any kind of installations in the German EEZ have to be granted by the Federal Maritime and Hydrographic Agency, BSH. The approval process is based on the German decree for sea installations (Seeanlagenverordnung).

The application for Borkum West was submitted in September 1999. Because, Borkum West was the first offshore wind farm requesting building permission in the EEZ, no specific investigation schemes existed in the “Seeanlagenverordnung” at the time. The developer, Prokon Nord, had to define this investigation programme itself. The first application hearing was held on 16 May 2000, to define the investigation programmes that the applicants had to carry out in order to receive a building permit. The BSH and involved stakeholders discussed and adapted the approval needs, which BSH then defined formally.

The later offshore wind farm applications for the subsequent projects had also to come up with their own concepts for the investigation programme. A standard investigation concept<sup>10</sup> (StUK) was launched by the BSH in December 2001, and has been obligatory since. This standard investigation concept is based on the experiences gained within the first projects.

In April and October 2001, the results of a pre-investigation by Germanischer Lloyd, a risk analysis concerning ship safety, was presented to the BSH. Partial approval was granted in July 2001, based on the documents submitted so far.

#### ***Approval procedure for grid connection:***

As mentioned above, the permission for laying the sea cable requires several different permits from different boards. The sea cable permit for the EEZ was declared to be dependent on the Exemption from the prohibitions of the National Park, as approval of the latter is far more complex. The exemption from the prohibitions of the National Park is the basic requirement for the permission of the sea

<sup>10</sup> Standarduntersuchungskonzept für die Untersuchung und Überwachung der Auswirkungen von Offshore Windenergieanlagen auf die Meeresumwelt (StUK), Bundesamt für Seeschifffahrt und Hydrographie, Hamburg und Rostock, 2003.

cable route in the 12-nmi zone. The optimal route of the cable in the 12-nmi zone was determined during the approval process.

The most difficult part in determining the cable route is the crossing of the National Park “Wattenmeer” and/or of the shipping routes from and to the coast. All coastal area along the German North Sea coast falls under one of these two designations; there are no sea areas without the restrictions of the National Park or the shipping zones.

***Embedding in spatial planning:***

In the discussions to find the cable route with the least impact on the various competing utilisations, the government of the State of Lower Saxony elected to carry out a spatial planning procedure. This spatial planning was performed by the regional administrative board.

The spatial planning process relied on the detailed planning provided by the developer. Prokon Nord had performed an analysis of eleven cable routes in total, of which seven were investigated in-depth. The seven investigated routes are depicted in Figure 4-2. From these initially proposed routes, two remained as the least conflicting:

- a) the route across the island of Norderney, crossing the National Park
- b) the route through the river Ems, leading along the shipping routes to the harbour of Emden

Route b) was strictly rejected by the shipping authority, “Wasser- und Schifffahrtsdirektion Nord” (WSD), leaving only the Norderney route as a possible solution. Moreover, it turned out during detailed investigations, that option b) would lead to a long route in parallel to the boundaries of the National Park. The result would be a far larger impact on the National Park by option b) than by directly crossing the south of Norderney with only a short distance as proposed in option a).

Prokon Nord originally planned the Norderney cable route for four cable systems: one for the 60 MW pilot phase and the other three systems for the 1000 MW extension phase. While the first cable was planned to be a three-phase AC high-voltage cable, the additional three were planned to be bi-polar cables for high-voltage DC (with IGBT rectification) connection.

In fact, the spatial planning process of the regional administrative board was confronted with applications by other offshore wind farm developers. The board decided to include these additional projects in the spatial planning process for Borkum West. This turned out to be a major drawback for Prokon Nord: the cable route was finally approved, but only for the three-phase AC cable of the pilot project. Other cable systems in this route will be approved by the board, but for the pilot phases of the further developers. For Prokon Nord, this results in a thoroughly opaque situation regarding the planning of the extension phase, as the extensive efforts already made to find the appropriate cable routes will have to be repeated for the second construction phase.

The permission to lay the sea cable in the 12-nmi zone was granted in autumn 2004, and the BSH granted permission for the cable route in the EEZ in December 2004.



### **Environmental impact assessment**

An environmental impact study was performed for each of the analysed cable route variations, and each for two types of grid connection technology. The EIA was carried out for each route for

- a) the pilot phase with 110-kV HVAC
- b) for the extension phase with a bi-polar HVDC system

The EIA paid particular attention to the electric and magnetic fields, as well as the heat development in the seabed around the cable, see Figure 4-3.

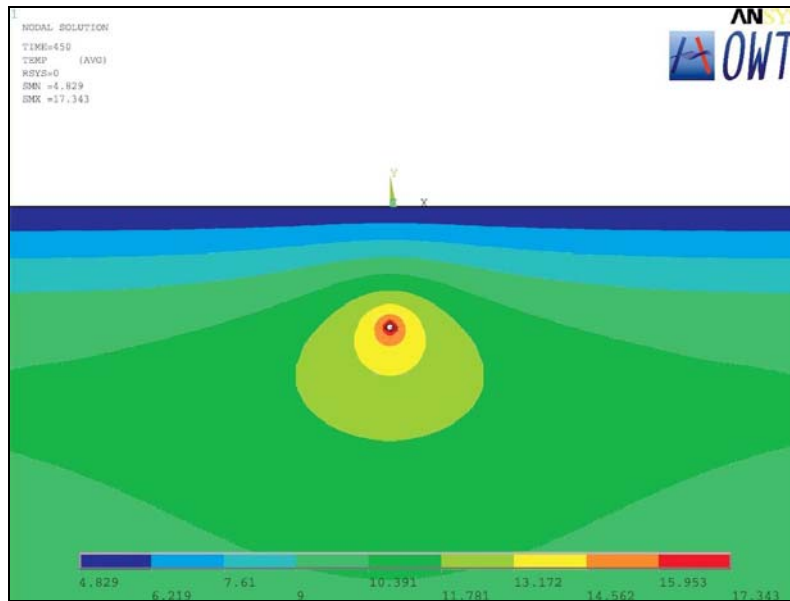

Figure 4-3: Heat distribution around the AC cable planned for the pilot phase (after 450 days, during winter)<sup>12</sup>.

Environmental investigations were performed from late summer 2000 until May 2003. The pilot phase serves as the basis for the environmental impact assessment concerning the final extension phase.

#### **Traffic safety and collision risk analysis:**

Due to the large distances to the traffic separation zones, any issues regarding safety and ease of the ship traffic have been resolved. A hindering effect from land radar, signal lights and navigation marks can be excluded. Moreover, the installation of radar reflectors and sonar

transponders is envisaged.

#### **Conflicting area utilisation:**

Within the intensive pre-planning activities, all competing utilisations in the proposed area that could possibly be affected by the project development were considered. Coast fishery will not be affected, due to the large distance to the coast and being above the 54° latitude (coastal fishery ends and deep-sea fishing starts at 54° latitude).

Moreover, the long distance of 45 km to the next of the East Frisian islands will prevent any impacts on tourism activities. Ecologically worthwhile areas such as designated Important Bird Areas, National Parks or other areas of special protective character (like the Borkum-Reef-Ground – Borkumriffgrund – for example) are not affected. A project plan close to ecologically valuable, sensitive areas of the Wadden Sea was rejected at the start of the planning phase.

<sup>12</sup> OWT, Offshore Wind Technology GmbH, Leer, Germany

**Stakeholder involvement:**

The approval process for the offshore wind farm by the BSH includes the involvement of all relevant public agencies and stakeholders. Involved are local communities, regional administration, tourism, fishery, sports associations, nature and environmental organisations, utilities and network operators, military and public agencies like mining, ship traffic, aeronautics, environment, nature, dikes etc. The application was made publicly and was discussed with invited stakeholders at an application hearing. In total more than 50 different stakeholders are involved in the consenting process

The required investigations, site screening and monitoring programmes were influenced by the hearing participants.

**Site investigation:**

The investigation programme determined for the Borkum West wind farm was the basis of and complies with the Standard Investigation Programme (StUK) of the BSH from 2003. This concept requires site screening of the avifaunistic and marine environment. Birds, fish, sea mammals and benthos have to be investigated within the framework of this concept, according to the following schedule:

- Basic assessment: two consecutive years of investigations without interruptions
- Installation phase: continuous monitoring
- Operation phase: after operations commence, the wind farm environment has to be monitored for three to five years.

The area to be investigated is the entire wind farm area, plus a reference area of the same size. The reference area will be investigated to allow comparison between the wind farm area and an area with the same marine conditions, but not impacted by any kind of installations. The reference area has to lie in the same sea region, with similar conditions (stream, water depth, type of sediment, distance to shore, spectrum and density of species), but must not be influenced by the wind farm.

The investigations were carried out at the wind farm site and reference area by a research vessel. The site screenings were carried out by a lot of different professionals, as the Alfred Wegener Institute für Polar- und Meeresforschung (AWI) Bremerhaven, the Vogelwarte Helgoland, the Forschungs- und Technologiezentrum Westküste, Büsum, BioConsult SH, Husum, Nautik Nord, Kiel – just to mention the major ones. Surveys have been done in different campaigns all over the year in the time period from August 2000 to May 2003. The mainly deployed vessels were:

- Eltra: 30 m ship, a former deep-sea fishing boat
- Aurora: a buoy-laying ship of 35 m length, with improved positioning gear
- Victor Hensen: 39 m, research ship, 25 days of scientific work; economic speed 10 kts, see Figure 4-4.
- Ems Pull II, 25m, sea-going tug.

In addition, 15 flights were conducted with small aircraft, to count birds and sea mammals.



Figure 4-4: Research ship Victor Hensen (Source: Prokon Nord).



Catching benthos



Van Veen catcher for sediment probing



Photo: sledge



Picture from sea bottom



Catching fish by beam trawl



Catching fish by bottom trawl

Figure 4-5: Pictures from site screening investigations (Source: Prokon Nord).

Site scans were carried out by Nautik Nord to determine the seabed profile and homogeneity of the seabed soil, see Figure 4-6. The seabed sediment is scanned to a depth of up to 30 to 40 m, providing a picture of the soil.

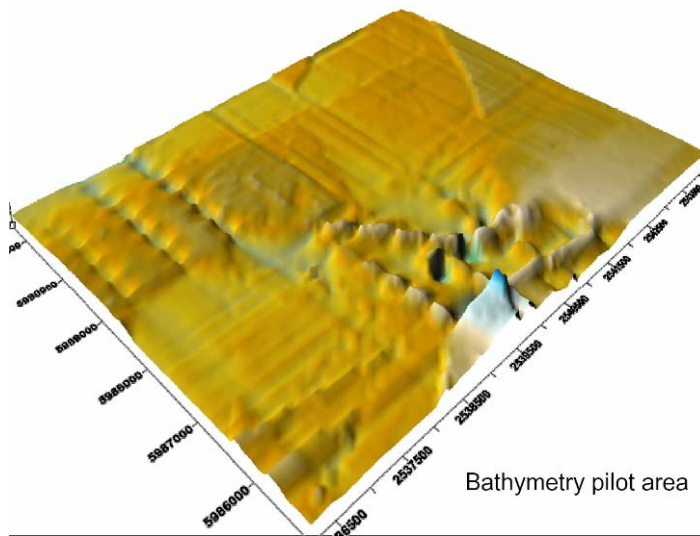

Figure 4-6: Plot of the seabed surface recorded during a site scan (Source: Prokon Nord).

Measurements of meteorological conditions were not carried out, as the offshore research platform “Fino I” lies within the vicinity of the wind farm area. The research platform was installed by the Federal Environmental Ministry, BMU, and is operated by Germanischer Lloyd. Fino I’s objective is to assess the basic meteorological and marine conditions for offshore wind farm development. The measurement data are available from Germanischer Lloyd, the measured meteorological parameters and an image of the platform are shown in Figure 4-7.



Meteorological parameters	Measurement height
Wind speed	100, 90, 80, 70, 60, 50, 40, 33 m
Wind direction	90, 70, 50, 33 m
Temperature	100, 70, 50, 40, 33 m
Humidity	100, 50, 33 m
Air pressure	100, 20 m
Global insolation	33 m

Figure 4-7: Research platform “Fino”.

### 4.2.2 Economics

#### *Economic and financial issues:*

The financial figures of the Borkum West wind farm were calculated at the beginning of the planning phase and remained largely unchanged (see Table 4-6 for figures). The specific costs of the pilot phase amount to approximately 2300 €/kW, more than twice the price of current onshore wind farm projects.

Table 4-6: Economic figures of the pilot phase.

<b>Item</b>	<b>costs</b>
Wind turbine ready installed	9 mil.€
Total wind turbine costs	108 mil.€
Grid connection	30 mil.€
<b>Total wind farm cost</b>	<b>138 mil.€</b>
Specific price per kW	2'300 €/kW

According to the developer, the project is economically viable, assuming a standard wind farm financing scheme (which basically implies interest rates at the same level). If the financing banks increase their interest rates to cover a higher risk level, economic viability may still be given, but at a level which is no longer interesting for investors. To overcome this situation, a state guarantee to cover the loans would help substantially. The economic situation may improve in the extension phase, as the specific cost for grid connection may come down due to the larger capacity of the sea cable.

### 4.2.3 Technology

#### *Selection of the technologies:*

From the start of the project planning, it was clear that the largest turbines available on the wind energy market should be used. The turbines under development were of the 5 MW size, pitch-controlled and speed-variable, with a rotor diameter of around 110 m. The plans relied on this size. When Prokon Nord took over ownership of the Multibrid offshore wind turbine technology from manufacturer Pfleiderer Wind Energy GmbH in November 2003, this turbine became the preferred type in the project planning for Borkum West. The first 5 MW Multibrid turbine has been running as a prototype at Bremerhaven, Germany since August 2004.

With the transfer of ownership of the Borkum West pilot phase to the Offshore Foundation, the selection of turbine types will change. The size will very likely remain 5-6 MW, but three different turbine types from three different manufacturers will be installed.

#### *Tripod foundation:*

To select the most suitable foundation and undersea construction, several different types were principally investigated at first (see Figure 4-8). These support structures were subject to static (century wave, 50-year gust, etc.) and dynamic load calculations and especially investigated with respect to fatigue effects induced by the turbine. In consequence, it turned out that the tripod-type support structure tends to be the most economical solution for the site.

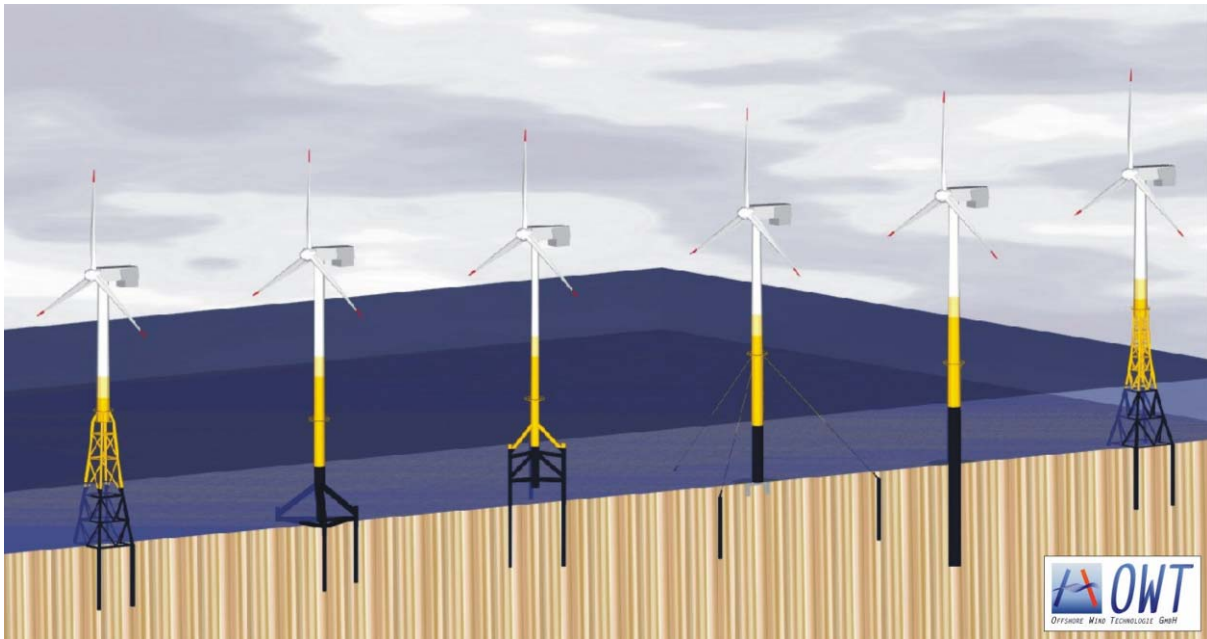

Figure 4-8: Different foundation types<sup>13</sup>.

***Pre-testing of techniques:***

The prototype of the Multibrid turbine has been in operation since August 2004. According to the developers, the turbine shows high reliability – around 99% in the past month.

***Grid connection:***

Different transmission technology has been chosen the pilot and extension phases. The transmission system for the pilot phase will be HVAC, with a medium voltage level of 36 kV for the wind farm internal network and a high voltage level of 110 kV for connection of the wind farm to the onshore grid. The substation for transforming medium voltage to high voltage will be at sea; all wind turbines will be connected to this substation. From the substation, the HVAC sea cable will lead to shore. The planned cable route is depicted in Figure 4-10.

---

<sup>13</sup> OWT, Offshore Wind Technology GmbH, Leer, Germany

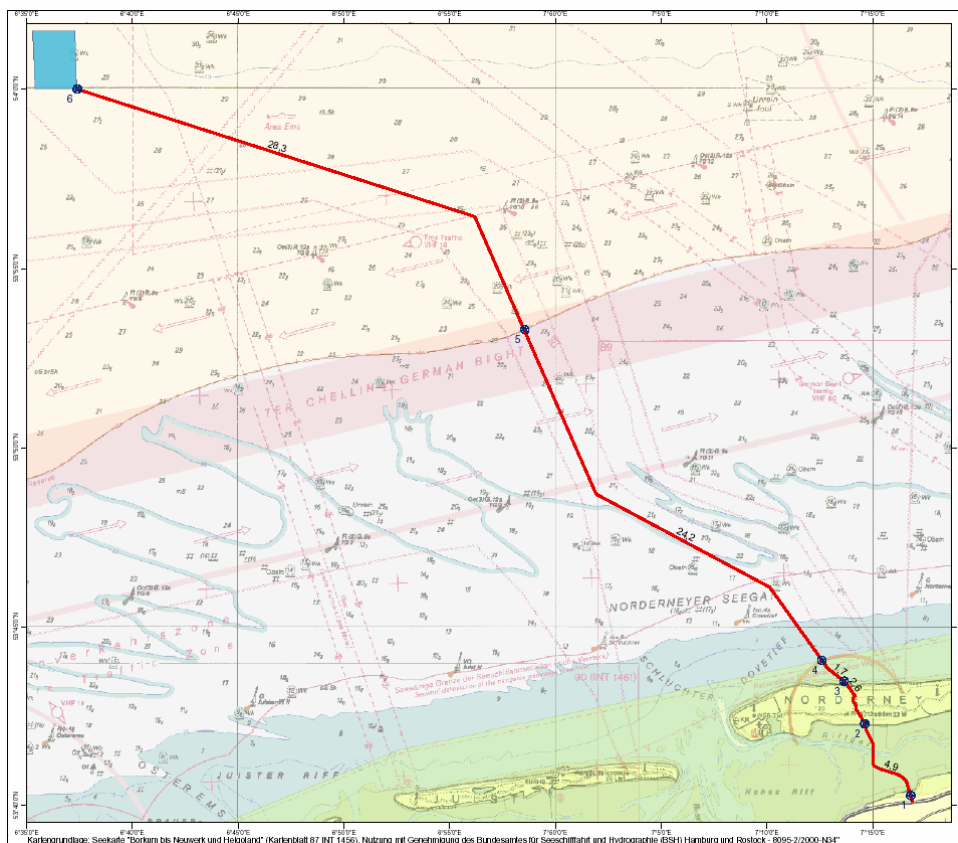

Figure 4-9: Planned cable route to connect the wind farm (blue rectangle in the upper left corner) with the onshore connection point.

From the landing point, a small village, Hilgenrieder Siel, the onshore route will lead to the high voltage interconnection network at Emden Borsum. The distances to bridge are:

- 70 km for the offshore cable
- 45 km for the onshore cable.

Due to the higher losses of the HVAC system, a bi-polar HVDC transmission will be chosen for the extension phase. In this case, the 36 kV AC of the wind farm internal network will be converted into a high-voltage direct current. The sea cable will be a bi-polar DC cable, transporting the energy to the point of common coupling, where the DC voltage is again converted to high-voltage alternating current.

Each of the turbines in the offshore wind farm will be equipped with an individual transformer, to transform the low voltage of the wind turbine generator into the 36 kV voltage of the wind farm internal network.

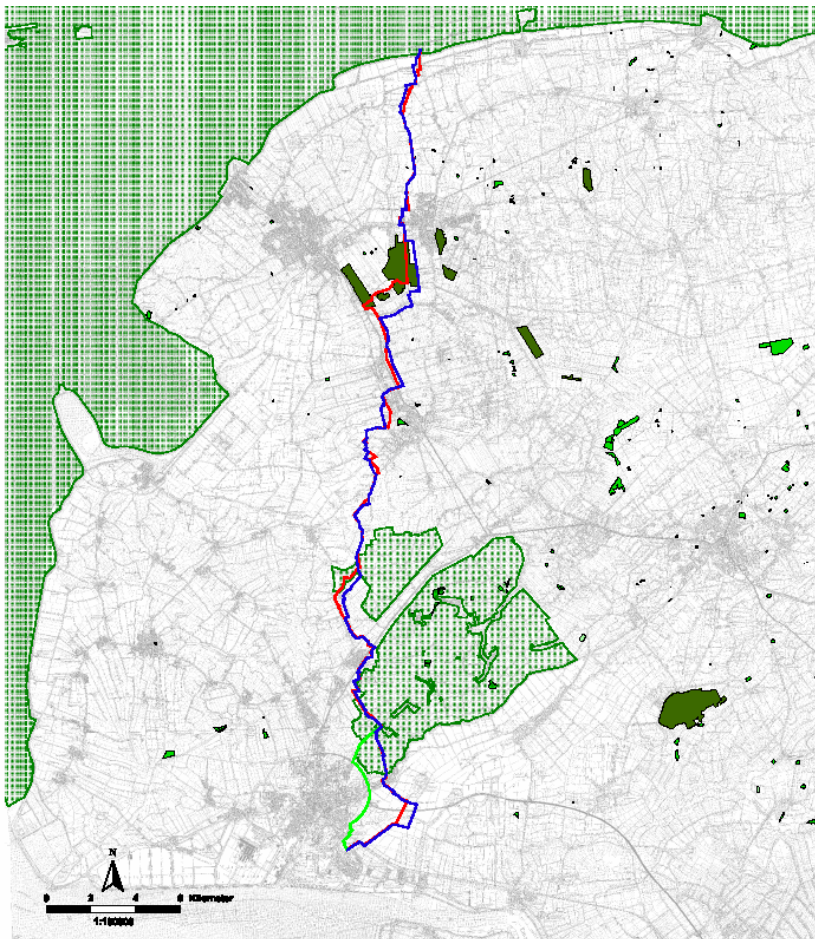

Figure 4-10: Onshore cable route.

### 4.3 Installation and operation phase

The Borkum West wind farm was scheduled to start operation in 2006. Following the changed ownership and operational concept, however, the actual start of installation activities has not been decided yet. As described above, the wind farm will be split up into three groups of four wind turbines each, with each group having a different turbine type. Separate operations are also being considered, as the wind farm is seen as test site for offshore turbines from different manufacturers.

### 4.4 Lessons learnt

#### *Site selection:*

The early planning stage tried to avoid areas with potentially competing utilisation and nature preserve conflicts. Therefore, the 12-nmi zone was excluded, to avoid conflicts with tourism-oriented East Frisian North Sea islands such as Borkum., Juist and Norderney. The area between the shipping routes of the German Bight was selected, but also with care: a maximum distance to both routes was pursued. The Borkum West area was then selected and deemed to have a minimum of conflicts with nature and environmental impact.

From today's point of view, the initiators of the project must acknowledge that later project developments were carried out with less caution, with a shorter distance to the shipping routes and/or within the 12 - nmi zone.

**Site investigation concepts:**

The first offshore wind farm approvals for the EEZ were based on investigations which were developed by the applying parties in agreement with the BSH, and which were modified and adapted during the discussions with the involved stakeholders. From the experiences gained from the definitions and performance of the investigations, two standard investigation concepts were launched in 2003 by BSH (see also Figure 4-11):

- “Standarduntersuchungskonzept für die Untersuchung und Überwachung der Auswirkungen von Offshore Windenergieanlagen auf die Meeresumwelt (StUK), Bundesamt für Seeschifffahrt und Hydrographie, Hamburg und Rostock, February 2003” for the investigation and monitoring of the impact of offshore wind turbines on the marine environment
- “Standard Baugrunduntersuchung, Mindestanforderung für die Gründung von Offshore Windenergieanlagen und die Verlegung der stromführenden Kabel, Bundesamt für Seeschifffahrt und Hydrographie, Hamburg und Rostock, August 2003” for the definition of the minimum requirements for the foundation of offshore wind turbines and for the laying of the conducting cables

These two standards today are the basic guidelines for the approval process of offshore wind farms in Germany, which all applicants are required to follow.



Figure 4-11: Standard concepts for EIA and site and seabed investigations.

**Concept:**

The concept of the Borkum West initiators of building the wind farm in two separate phases, a pilot phase and an extension phase, very soon became a basic requirement of BSH for further projects. An ongoing issue is still whether the size of the wind farm, as planned by Prokon Nord, is too small to be an economically viable project or if it is the best economic solution for a pilot project.

***Technology:***

Based on the state of planning, no major changes in the planned technology are needed yet. The technological approach was straightforward.

## 5 Butendiek (Germany)

### 5.1 General

#### 5.1.1 Project description

The Butendiek project was planned from the start as a co-operative wind farm, owned by private parties in the region and leaving most of the economic benefits in the state of Schleswig-Holstein. This ownership concept is similar to the concepts of a large number of onshore wind farms in Germany (and of course in Denmark). The project aimed to obtain complete financing for the planning phase, as well as a large amount of equity capital for project realisation, on a private basis.

Table 5-1: General description of Butendiek Offshore Wind Farm.

Project description: Butendiek	
Project name	Offshore Bürger-Windpark Butendiek
Country / region	Germany, Schleswig-Holstein
Owner / Investor	OSB Offshore-Bürger-Windpark Butendiek GmbH & Co. KG
Developer	OSB Offshore-Bürger-Windpark Butendiek GmbH & Co. KG
Operator	OSB Offshore-Bürger-Windpark Butendiek GmbH & Co. KG
Location, geographical position	The wind farm is located west of the North Frisian island of Sylt, south of the Danish border; position 54°N 50'; 7°50'
Area	34 km <sup>2</sup>
Water depth	16 – 20 m
Distance to shore	34 km
Operators website	<a href="http://www.butendiek.de">www.butendiek.de</a>

#### 5.1.2 Technical data

Table 5-2: Technical data of Butendiek Offshore Wind Farm.

Technical data: Butendiek	
Total MW	240
Number of turbines	80
Turbine manufacturer and rating	Planned Vestas, 3 MW
Hub height (m)	80
Rotor diameter (m)	90

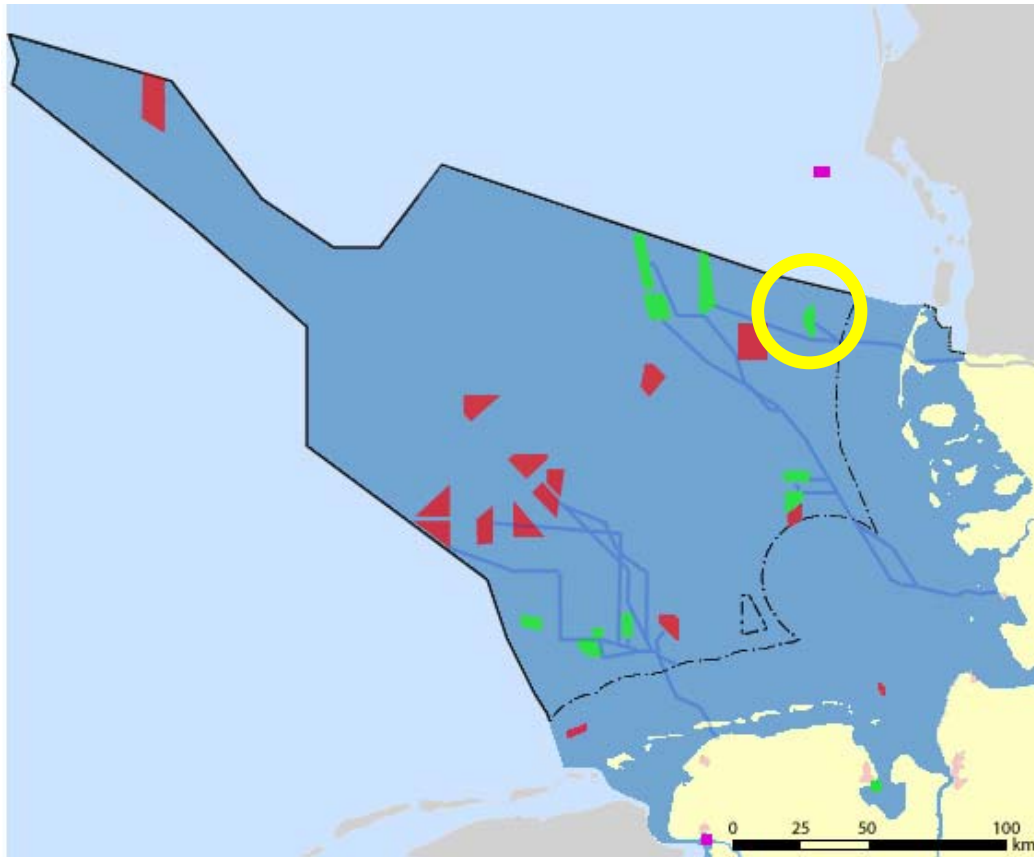

Figure 5-1: Planned offshore wind farm within the German EEZ, the location of Butendiek is indicated by a yellow circle<sup>14</sup>.

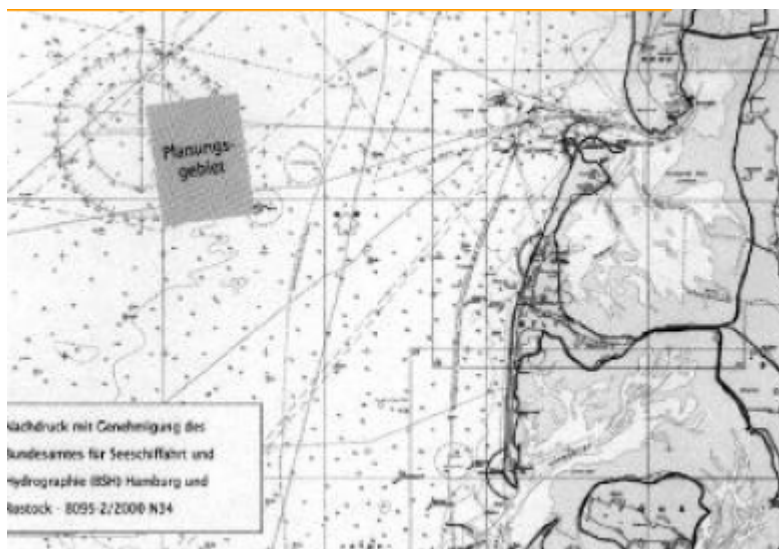

Figure 5-2: Geographical position of Butendiek wind farm.

<sup>14</sup> [www.offshore-wind.de](http://www.offshore-wind.de), German Energy Agency

### 5.1.3 Time frame

The project so far is separated into two phases, planning and installation.

In phase one the proposal was subject to a project hearing in July 2001. Approval for the building of the wind farm was given in December 2002 by the Federal Office for Shipping and Hydrography (BSH) in Hamburg. The planning phase will end with the contract negotiations and the financing covenant, which is foreseen for the second half of 2005.

In phase 2, the project was scheduled to switch to the construction phase. This was foreseen for summer 2006. The finalisation of equity and outside capital allocation was planned for autumn 2005, but had been postponed to mid 2006 at the time this report was prepared, due to problems with the financing banks.

The completion of the wind farm is scheduled for autumn 2007.

Start of planning	Spring 2000
Planning phases, time schedule	Autumn 2000
Installation start	Soonest 2007/8
Start of operation	Soonest 2008

The approval phase for the wind farm has already passed the main subjects. The Butendiek wind farm, including offshore and onshore cable route, will receive full permission by spring 2006. The installation phase of the wind farm could therefore start in 2006, but the project is currently experiencing problems with economic viability due to major constraints in the financing scheme.

## 5.2 Project planning phase

### 5.2.1 Planning, approval and communication

#### *Project management:*

The OSB Offshore-Bürger-Windpark Butendiek GmbH & Co. KG was initiated by nine private parties who live and work in Schleswig-Holstein. These individuals are already involved in management and/or consulting and technical design for public wind farms.

The pre-project planning was performed by the nine initiators of the project. The planning phase was then performed by OSB Offshore-Bürger-Windpark Butendiek GmbH & Co. KG. The banks Kreditanstalt für Wiederaufbau (KfW) and HSH Nordbank Kiel were awarded a contract to work out the financing scheme. F+Z (Bilfinger Berger) and Vestas conducted joint planning for the installation phase.

To increase public acceptance, public hearings were held at different locations and on various occasions.

#### *Planning (legislative):*

The wind farm site was subject to an approval procedure. At the start of the project, the Butendiek proposal was reviewed by the relevant public agencies and stakeholders. In the next step, a first approval hearing was held, stating that different investigations – such as a collision risk analysis – should be performed.

The project approval was associated with a request to perform an Environmental Impact Assessment with a focus on birds, fish, common porpoises and benthos. As Butendiek also started with the approval process early, the concepts for the EIA and the related investigation programme had to be

designed by the project team itself. The concept was presented to the BSH and had to be revised in some details, but as it was similar to the Borkum West project, the Butendiek concept also served as input to the StUK defined by the BSH.

The investigations should be performed during the planning, building and start-up phase of the wind farm. During the three-year planning phase (2001-2004), all relevant environmental impact parameters were investigated in the proposed wind farm area, as well as in an additional reference area.

***Approval process for grid connection:***

The offshore cable will lead from the wind farm eastwards to the island of Sylt. It will cross Sylt on its southern end and follow the Hindenburg Damm, the connection dam between the island and the coast. The onshore cable will lead along the border to Denmark, to connect to the utility high voltage grid at Böxlund. Cable length:

- Offshore: 50 km
- Onshore: 50 km

The cable has to cross three districts and ten communities. Several public hearings were held with the affected communities and landowners, five hearings on Sylt and approximately 190 more on the mainland.

On Sylt, the route will bypass Campen and Sylt East, as these communities are against the offshore wind farm. The City of Westerland will sign the land lease and utilisation contracts in next future. The price for land lease is the same along the route.

The permits required for the offshore cable are:

- Building permission for the pilot phase
- Permission for laying the cable in the seabed by the authorizing agency for river and navigation-specific police approval
- Lease contract to use the 12-nmi zone for laying a sea cable
- Water and Dike Permission, approval to cross dikes and waters
- Exemption from the prohibitions of the National Park
- Permission for laying the sea cable in the EEZ
- Consent for grid connection

The permits required for the onshore cable are:

- Nature conservation approval by the state administration
- Permissions to cross federal, state, district and community roads
- Permissions to cross dikes and rivers
- Permission to cross train tracks
- Approval by the agency for protection of historic buildings and monuments

The main permission is the approval by the Nature Conservation Agency, which is in process and is expected in early spring 2006. Contingent on this approval, the other permissions will also be received early next year.



Figure 5-3: Offshore cable route across the North Frisian island of Sylt.

#### **Site investigation:**

In the framework of the EIA, numerous site-screening investigations were performed by vessels and aircraft. Two ships from a Danish shipping company based in Esbjerg were used primarily for the screening tours. Basically, radar measurements and visual inspections were employed to count resting birds and sea mammals. Butendiek was the first company to use small aircraft for this purpose, a method which proved to be quite efficient and was used by other developers as well.

An additional seabed survey was carried out by means of drillings and a conic penetration test (CPT). The tests were primarily performed by a jack-up platform owned by Mohiba, an offshore company (see Figure 5-4). Additionally CPTs were carried out by special vessels from Fugro, The Netherlands.



Figure 5-4: Drilling and conic penetration test with a platform from Mohiba.

A site scan with sonar devices was performed using small 30 m boats from the Danish shipping company.

## 5.2.2 Economics

### *Economic and financial issues:*

The financing of the project planning and the project itself was supposed to be based widely on money from private parties from the region in Northwest Schleswig-Holstein. The project planning is based completely on private money, while the project itself is supposed to have an equity capital of 25%.

To collect the 5 € mil. required for the planning phase (see Table 5-3), 20,000 shares with a par value of 250,-€ each were sold to private people. Due to the delay in developing the project, an additional amount of 1mil.€ was needed to finance the extension period. This additional amount was paid solely by the nine project initiators.

Table 5-3: Project costs.

Item	Total Costs
Project planning	5 mil.€ plus additional 1 mil.€
Planned project costs	420 mil. €
Specific costs	1750 – 2100 €/kW

To financing the total project, the shareholders have to pay in an additional amount. These single shares of € 4,750.00 from each of the 20,000 shareholders will provide the complete equity capital for the entire project realisation (see Table 5-4).

The planning period was kept lean, in order to avoid high costs. Project management and administration were performed with a minimum of financial effort: most of the work was done unpaid by the initiators, merely office rent and one secretary had to be paid. The major share of the planning was dedicated to the investigations and expertises for the approval process. To avoid having to collect higher shares from the shareholders for the extension of the planning phase, the initiators paid the additionally required 1 mil. € themselves.

Table 5-4: Shares by private people for planning and project equity capital.

	Number of shares	Shares	Cost
Planning	20000	250	5'000'000 €
Project equity	20000	4'750	95'000'000 €
Total equity capital		5'000	100'000'000 €

The financing of the complete project cost of 420 mil. € is based on 24% equity capital from the shareholders and outside capital of 76% (see Table 5-5). Therefore, a second contribution of € 4,750 is required from each of the shareholders.

For the moment, as long as project continuation is on hold, the project initiators will not request any more capital from the shareholders, which means the shares will remain the same until realisation begins.

Table 5-5: Equity and outside capital for the total project financing.

	Share	Cost
Equity share	24 %	100 mil. €
Outside financing	76 %	320 mil. €
Total project financing		420 mil. €

### ***Project financing***

The reason why the project is on hold is its financing. The project was originally planned with specific costs of 1400,-€/kW. Today, however costs have risen above 2000,-€/kW, due to a variety of reasons including:

- a) The costs for turbine have increased due to rising raw material and energy costs for steel (mainly foundation and tower), copper (sea and land cable) and oil (manufacturing).
- b) The market situation for wind turbines on the German market has changed drastically: Germany, formerly the most important market for turbine manufacturers, has lost attraction, as wind energy is booming around the world; feed-in tariffs are higher in several countries (e.g. Italy).
- c) Outside financing by banks is far more expensive than was supposed in recent years.

The former two items are due to the global market situation and are beyond the influence of German finance and politics. The latter item is the result of increased demands by banks that all possible risks be covered by expensive guarantees and by higher interest rates for the loans. The interest rates demanded from the banks lie far above those for onshore wind farms. While onshore wind farms currently pay interest rates of around 3%, twice that amount – 6% – is demanded for offshore wind farm financing.

### **5.2.3 Technology**

#### ***Selection of the technologies:***

Butendiek selected the Vestas V90 wind turbine. The standard type has been specially modified, based mainly on the experiences gained by Vestas in the Horns Rev project. Modifications will be made for:

- condition monitoring system: improved features
- encapsulated cooling
- oil-cooled transformer (the air-cooled transformer used in the Horns Rev turbines had significant insulation problems)

The foundations were planned as monopiles with a total length of 70 m:

- foundation / tower adaptor at a height of 20 m above sea level
- water depth 20 m
- foundation depth in the seabed 30 m

**Grid connection:**

The wind farm will be connected to the high-voltage line at Böxlund, in the district of Flensburg. The sea cable was to cross the island of Sylt, where a connection to a substation will be made to establish a new power supply for the island.

The transmission technology utilised is HVAC; the voltage levels of the connection system are listed in Table 5-6.

Table 5-6: Grid connection voltage levels.

Component	Voltage level
Wind farm internal network	33kV
Offshore cable connecting to the utility network	155kV
Grid connection level	400kV

All cables have to be buried at varying depths: 0,8 m for the wind farm internal network, 1,5 m for the sea cable in normal seabed and 3 m in specific areas such as reefs.

## 5.3 Installation and operation phase

### 5.3.1 Installation and grid connection

The wind farm installation will be performed by the companies F+Z and Vestas, the cable will be laid by SAG and NSW. The companies will hire subcontractors to perform various subtasks.

Esbjerg Harbour is intended to be the installation base. OSB will take over operation and technical management.

## 5.4 Lessons learnt

### *Project financing:*

One of the major obstacles in realising the Butendiek, as well as further wind farms in Germany, lies in the poor ratio between project costs and reimbursement. The increased costs for wind turbines and offshore foundations is one factor, and can be influenced only marginally. The offshore wind farm developers currently are searching for cheaper alternatives for building offshore foundations, e.g. by introducing concrete foundations.

The second factor, expensive demands from banks that all possible project risks be covered by expensive guarantees and high interest rates, is subject to potential solutions by German finance and politics. Several strategies to improve the financial situation of German offshore wind farms are being discussed:

- a) Lowering interest rates to the current standard values for industrial projects of 3% (instead of 6%)
- b) A dedicated subsidy programme paying 2 to 3 ct/kWh, in addition to the EEG granted reimbursement
- c) Adaptation of the tariffs defined in the EEG to a cost-covering amount (e.g. 12ct/kWh)
- d) A shift of the common coupling point of the utility grids to the outer side of the islands in the German Bight or directly into the offshore wind farm areas

e) State financing guarantees, to lower risks and thus reduce interest rates and insurance fees  
These solutions either increase reimbursement or lower costs (by lowering risks). Butendiek wind farm cannot be realised at the present time: in the current situation, shareholders would gain only minor reimbursement – equivalent to an annual return of just 3% – connected with a comparatively high risk. This level would not even be attractive for onshore projects; yields of 10% are demanded for offshore projects, to account for the higher risk.

***General offshore wind farm development in Germany***

Despite the development of offshore wind farms in other countries such as Denmark and Great Britain, the costs for German projects are higher. These higher costs result from the long distances to the coastline (and to the point of common coupling), with cable lengths of up to 100 km, and from the greater water depths in the German Bight.

## 6 Greater Gabbard (United Kingdom)

### 6.1 General

#### 6.1.1 Project description

The Greater Gabbard Offshore Wind Farm is located in the Outer Thames Estuary (see Figure 6-1). The British government has identified this region as one of the three strategic areas for the second round of offshore wind farm development in the UK. The wind farm shall be commissioned in 2009.

The wind farm is located 23 km off the Suffolk Coast, at two shallow sandbanks known as the Inner Gabbard and the Galloper. The site lies both inside and outside UK territorial waters. Wind farm planning foresees up to 140 turbines with an installed capacity of 500 megawatts. The cables shall be brought ashore via a new, adjacent onshore substation. It shall be connected to the existing 400 kV line at Sizewell, near Leiston in Suffolk.

Table 6-1: General description of the Greater Gabbard Offshore Wind Farm.

Project description	
Project name	Greater Gabbard Offshore Wind Farm
Country/region	United Kingdom, Outer Thames Estuary
Name of owner	Greater Gabbard Offshore Winds Ltd (GGOWL) – Joint venture of Airtricity Ltd. and Fluor Ltd.
Name of developer	Greater Gabbard Offshore Winds Ltd
Location	Outer Thames Estuary, off the Suffolk Coast
Area in km <sup>2</sup>	147 km <sup>2</sup>
Water depth range	3.6 m to 8 m (Inner Gabbard) 2.4 m to 10 m (the Galloper) 20 m to 50 m (off the banks)
Distance to shore	23 km (12 nautical miles)
Operator's website	<a href="http://www.greatergabbard.com">www.greatergabbard.com</a>

#### 6.1.2 Technical data

Table 6-2: Technical data of the Greater Gabbard Offshore Wind Farm.

Technical data	
Total installed capacity	500 MW
Energy generation per year	1,750 GWh per annum
Estimated average mean wind speed	8.50 to 9.50 m / s (predicted) at 80 m AMSL
Number of turbines	up to 140
Rating of turbine	3-7 MW

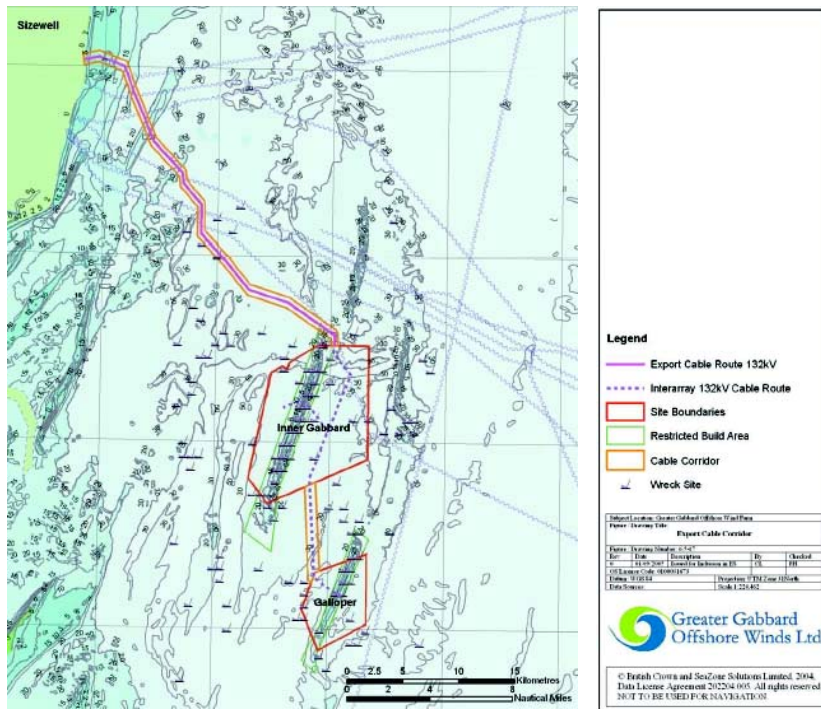

Figure 6-1: Location of the Greater Gabbard Offshore Wind Farm and route of export cables from wind farm to Sizewell<sup>15</sup>.

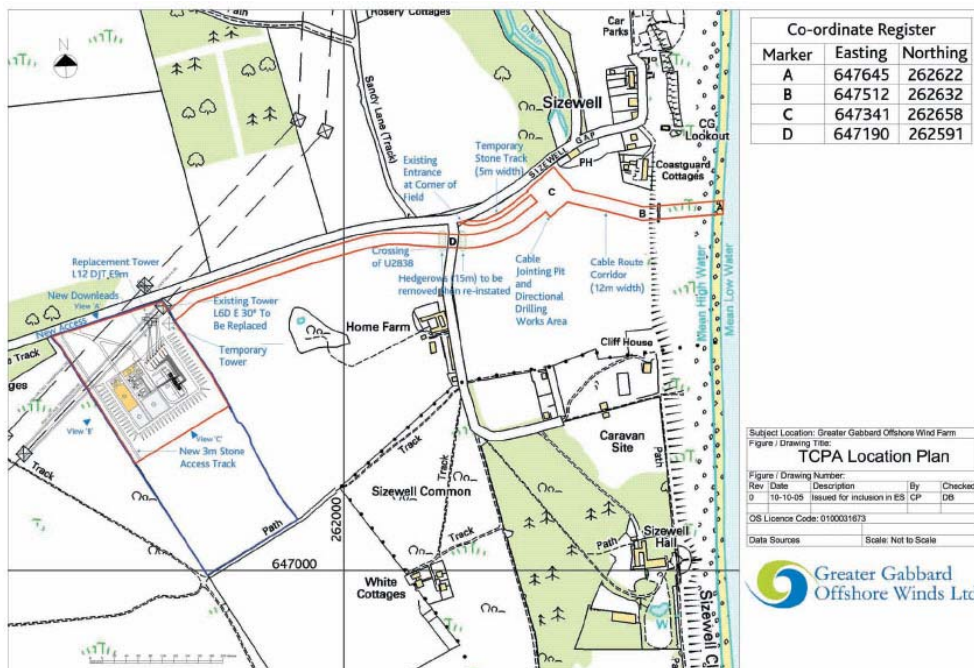

Figure 6-2: Location of onshore cable and onshore sub-station at Sizewell of Greater Gabbard Offshore Wind Farm<sup>16</sup>.

<sup>15</sup> Greater Gabbard Offshore Winds Ltd “Environmental Statement - Greater Gabbard Offshore Wind Farm”, October 2005, figure 6.5-17

<sup>16</sup> Greater Gabbard Offshore Winds Ltd “Greater Gabbard Offshore Wind Farm – Non Technical Summary”, October 2005

### 6.1.3 Time frame

GGOWL published the environmental statement in October 2005.

Greater Gabbard Offshore Winds Ltd has entered into a 50-year lease with the Crown Estate for the wind farm site.

The construction of the wind farm is anticipated to last 36 months:

- Construction will begin onshore in 2007 and offshore in 2008.
- Commissioning of the project will be completed in 2009.

The following timetables for the construction phase are taken from the environmental statement (see Figure 6-3).

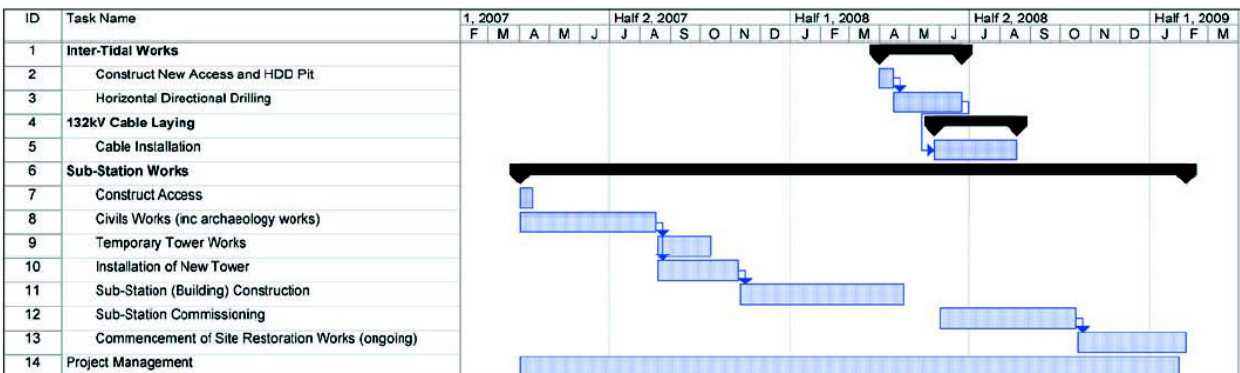
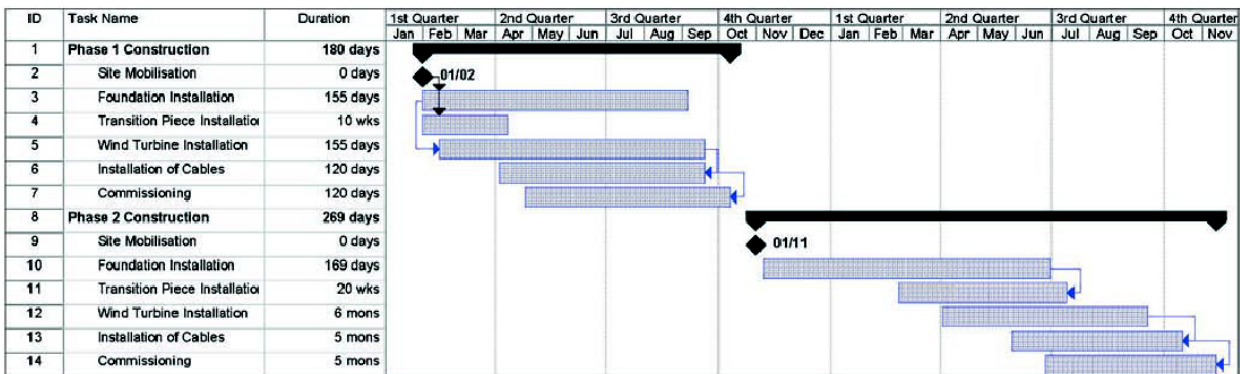

Figure 6-3: Timetables for onshore and offshore works of Greater Gabbard Offshore Wind Farm <sup>17</sup>.

## 6.2 Project planning phase

### 6.2.1 Planning, approval and communication

Greater Gabbard Offshore Winds Ltd (GGOWL) is a joint venture of the companies Airtricity Ltd and Fluor Ltd. Airtricity has a proven track record in the development, construction and operation of wind

<sup>17</sup> Greater Gabbard Offshore Winds Ltd “Environmental Statement - Greater Gabbard Offshore Wind Farm”, October 2005,

farm projects; it launched the first phase (25 MW) of its offshore wind farm, located on the Arklow Bank off the east coast of Ireland, in May 2005.

#### Contracts and involved companies

The companies and institutions supporting Greater Gabbard Offshore Winds Ltd in the development of the environmental statement, and in obtaining statutory consents, are listed in Table 6-3.

Table 6-3: Companies and institutions supporting Greater Gabbard Offshore Winds Ltd in approval procedures<sup>18</sup>.

Name of Company / Institution	Subject
Project Management Support Services Ltd	Coordination, development and support of environmental impact assessment
SeaRoc	Engineering co-ordination, navigation risk assessment
British Trust for Ornithology	Ornithology
Centre for Marine and Coastal Studies	Benthic ecology, fish, marine mammals and onshore ecology
Subacoustech	Sub-sea noise
Maritime Archaeology Ltd	Marine archaeology
ABPmer	Coastal processes
Danbrit Ship Management Ltd	Commercial fisheries
Enviros	Offshore landscape and visual assessment
Eversheds	Legal support
Rambøll	Offshore conceptual foundation design
Sinclair Knight Merz	High-voltage system design, onshore landscape and visual assessment
Metoc	Sub-sea cables, export cable route
ISVR Consulting	Noise

#### ***Planning (legislative):***

Greater Gabbard Offshore Wind Farm requires the statutory consents listed in Table 6-4 below.

The consent regime for offshore wind farms has changed due to the provisions of the 2004 Energy Act: it is now possible to extend the consenting regime and related legal matters beyond UK territorial waters. A special regime for the construction and operation phase of the wind farm can be declared in safety zones and renewable energy zones: non-project vessels can be prohibited from coming too close to technical infrastructure and construction works. Trawling, anchoring and dredging within a defined area of structures (such as turbines, substation platforms and met masts) can be prohibited.

Greater Gabbard Offshore Winds Ltd will be applying for safety zones prohibiting entry for non-project vessels. The zones shall have a 50 m radius around each wind turbine structure, offshore sub-

<sup>18</sup> Greater Gabbard Offshore Winds Ltd “Greater Gabbard Offshore Wind Farm – Non Technical Summary”, October 2005

station and met mast platform. In addition, trawling, drift netting, aggregate extraction and dredging or anchoring (for non-project vessels) within 500 m of any wind turbine, substation platform or met mast will be prohibited.

Table 6-4: Permits Needed for Greater Gabbard Offshore Wind Farm<sup>19</sup>.

Subject	Legal Basis	Granting Authority
Construction and operation of the wind turbines, offshore transformer stations and met masts	Section 36 of the Electricity Act 1989	The Department of Trade and Industry (DTI)
Navigation extinguishment declaration	Section 36A of the Electricity Act 1989	
Overhead electric lines from substation to neighbouring existing 400 kV power line	Section 37 of the Electricity Act 1989	
Safety zones	Section 95 of the Energy Act 2004	
Installation of foundations of offshore structures, rock armouring, scour protection etc	Section 5 of the Food and Environment Protection Act 1985 Part II	The Department for Environment, Food and Rural Affairs (DEFRA)
Obstruction to navigation works	Section 34 of the Coast Protection Act 1949	
Planning permission for on-shore substation and cables	Section 57 of the Town and Country Planning Act 1990	Suffolk Coastal District Council

### ***Selection of site:***

Greater Gabbard Offshore Winds Ltd selected the site for the following reasons:

- Good wind resources
- Distance from shore reduces likelihood of visual impact
- Low maritime recreation usage
- No significant bird concentrations in the immediate vicinity of the site
- Few sites designated for nature conservation near the wind farm location
- Onshore electrical infrastructure is strong
- Candidate ports for construction and operations nearby
- Seabed properties for support structures are good
- No known marine archaeological sensitivities in the immediate vicinity
- Relatively little fishing activity in the vicinity of the site
- No Ministry of Defence or Civil Aviation Authority objections

<sup>19</sup> *ibid*

***Environmental impact assessment:***

Greater Gabbard Offshore Ltd published an environmental statement in October 2005. The scope of the Environmental Impact Assessment (650 pages) covers the period from commencement of the first phase of construction, through the operational phase, to completion of operations and decommissioning. It describes in detail:

- The need for the onshore and offshore works
- The process of site and cable route selection
- The design, construction, operation and eventual decommissioning of the wind farm, onshore and offshore cabling, onshore substation and connection to the onshore transmission grid
- Ancillary works
- Environmental impact assessment
- Assessment of alternative cable landfalls, on-land routes and substations
- Appropriate mitigation and monitoring measures.

Greater Gabbard Offshore Winds Ltd also published a non-technical summary, aimed at providing information to non-technical and non-specialist readers.<sup>20</sup>

An environmental management system is expected to be implemented corresponding to the different aspects of construction activities. An onshore environmental management system will also be implemented. The offshore system will include the following:

- Environmental management system
- Environmental management plan
- Monitoring protocol
- Incident-reporting and non-conformance procedure
- Emergency response plan
- Collision risk management plan
- Marine pollution contingency plan
- Dropped objects and materials recovery plan
- Archaeology plan
- Noise, dust and vibration management plan
- Waste management plan

***Commercial navigation and risk assessment:***

Greater Gabbard Offshore Winds Ltd conducted a navigation survey to account for measured shipping activity in the region. It modified the site boundary of the wind farm to account for measured shipping activity in the region. Greater Gabbard Offshore Winds Ltd undertook a navigation risk assessment on the revised site boundaries, and risk reduction measures have been identified. The highest risks posed in each of the major categories of collision, drifting, grounding, construction and access are:

- A vessel on a planned passage through the Inner Gabbard / the Galloper gap is forced to leave its planned track and enter the wind farm and collides with a tower or rotor
- A vessel becomes disabled, drifts into the wind farm and collides with a tower

---

<sup>20</sup> ibid

- A vessel grounds on the Inner Gabbard or the Galloper and either swings with the tide and strikes a tower or one of her salvaging tugs strikes a tower
- A construction vessel drops or drags its anchor over an unburied cable and damages it
- A member of the maintenance crew slips between the boat and the boat landing ladder (on a turbine) and is injured

**Media strategy:**

Greater Gabbard Offshore Winds Ltd quotes official papers and speeches to facilitate general political support of renewable energies and climate protection. The environmental statement contains excerpts of the following:

- Government White Paper “This Common Inheritance” (1990)
- The Royal Commission on Environmental Pollution in its report “Energy – the Changing Climate” (June 2000)
- Climate Change Programme in November 2000
- Energy White Paper “Our Energy Future – Creating a Low Carbon Economy” (2003)
- Statement of Prime Minister to Parliament on 11 July 2005 on the G8 Summit at Gleneagles

Greater Gabbard Offshore Winds Limited substantiates the wind farm with the need to reduce emissions of greenhouse and acid rain gases and to move towards a more sustainable future. Wind energy is a means of generating electricity which:<sup>21</sup>

- does not produce emissions of greenhouse or acid rain gases (produced electricity avoids the equivalent of an annual offset of more than 1,000,000 tonnes of carbon dioxide)
- produces electricity for domestic demand of 415,000 homes (1,750 GWh per annum)
- does not produce toxic waste products
- is not dependent on finite reserves of fossil fuels and
- is inherently sustainable

**Stakeholder involvement:**

The scoping report provided a description of the proposed development, information on the site location and an overview of environmental issues, and was sent to organisations listed in Table 6-5.

Greater Gabbard Offshore Winds Ltd utilised the following methods of communication in the Round 2 process:

- Direct consultation meetings / briefings
- Project introductory briefing to local and regional consultees, October 2004, Aldeburgh
- Pre-application briefing for officers and members of relevant councils, September 2005, Woodbridge.
- Project website [www.greatergabbard.com](http://www.greatergabbard.com)
- Project brochure with key project information developed in October 2004 (brochure has been distributed to consultees and the general public at events, meetings and on request)
- Public exhibition at the Jubilee Hall, Aldeburgh, on 23 October 2004. Elements:
  - Greater Gabbard project “story board” display

- General offshore wind farm information video
- Model wind turbine
- Greater Gabbard project brochure
- Greater Gabbard FAQ sheet
- Project developer information brochures (Airtricity / Fluor)
- Public questionnaire

Press releases titled as follows:

- Monday, October 17, 2005, “Greater Gabbard Offshore Winds Ltd Apply For Consent:  
”Greater Gabbard Offshore Winds Limited (GGOWL), an Airtricity and Fluor joint venture, today submitted an application for development consent for the construction of a 500 MW offshore wind farm to be located 25km off the coast of Suffolk around the Inner Gabbard and Galloper sandbanks. The application was submitted to the DTI, DEFRA and Suffolk Coastal District Council (SCDC) and follows the awarding of an Agreement for Lease by The Crown Estate in December 2003”
- Friday, October 29, 2004, “Response pleases wind turbine firm:  
”Officials behind a project to build one of the largest wind farms in the world off the Suffolk coast were delighted with the response when they put their proposals on view to the public.”
- Tuesday, October 26, 2004, “Wind farms exhibition feedback ‘encouraging:  
”OFFICIALS behind a project to build one of the largest wind farms in the world off the Suffolk coast were delighted with the response when they put their proposals on a public display. More than 150 people attended the exhibition on Saturday at Aldeburgh’s Jubilee Hall when details of the £700 million project to build 140 giant turbines 26 miles out to sea were displayed by Irish firm Airtricity.”

Table 6-5: Distribution of Environmental Impact Assessment scoping report for Greater Gabbard Offshore Wind Farm<sup>22</sup>.

Organisations		
Association of Sea Fisheries Committees of England and Wales	Essex County Council	Ramblers Association
Babergh District Council	Essex Wildlife Trust	Receiver of Wreck
Brightlingsea Harbour Commissioners	Friends of the Earth	Renewables East
British Helicopter Advisory Board	GE Wind Energy	RMC Marine
British Marine Foundation	Global Renewable Energy Partners	Royal Commission on the Historical Monuments of England
British Sub Aqua Club	Government Office for East of England	Royal National Lifeboat Institution

<sup>21</sup> Greater Gabbard Offshore Wind Ltd, “Why Wind”, [www.greatergabbard.com](http://www.greatergabbard.com), October 2005

<sup>22</sup> Greater Gabbard Offshore Winds Ltd “Environmental Statement -Greater Gabbard Offshore Wind Farm”, October 2005

British Telecom	Greenpeace	Royal Ocean Racing Club
British Trust for Ornithology	GT UK	Royal Society for the Protection
CEFAS	Hanson Aggregates	Royal Yachting Association
Chamber of Shipping	Harwich Haven Authority	Sea Mammal Research Unit
Council for the Protection of Rural England (Central and Essex)	International Chamber of Shipping	South Coast Shipping
Countryside Agency	Joint Nature Conservation Committee	Suffolk Coast and Heaths Unit
Cruising Association	Kent and Essex Sea Fisheries Committee	Suffolk Coastal District Council
DEFRA Sea Fisheries Inspectorate	Maldon District Council	Suffolk County Council
Department for Culture, Media and Sport	Marine Conservation Society	Suffolk Preservation Society
Department for Transport – Ports Division	Maritime and Coastguard Agency	Suffolk Wildlife Trust
Department of Environment, Food and Rural Affairs – Marine Consents and Environment Unit	MoD Defence Estates	Tendring District Council
Department of Trade and Industry	National Air Traffic Service	Thanet District Council
Directorate of Airspace Policy	National Federation of Fishermen's Organisations	The Crown Estate
East of England Development Agency	National Federation of Sea Anglers	Trinity House Lighthouse Service
East of England Regional Assembly	National Grid Transco	UK Hydrographic Office
East of England Tourist Board	Nautical Archaeology Society	Waveney District Council
Eastern Sea Fisheries Committee	Port of Felixstowe	Whale and Dolphin Conservation Society
English Heritage	Port of London Authority	Wildlife and Wetlands Trust
English Nature	Port of Lowestoft	World Wildlife Fund
Environment Agency	Port of Ramsgate	

### 6.2.2 Technology

This chapter's information are taken from Greater Gabbard Offshore Winds Ltd "Environmental Statement -Greater Gabbard Offshore Wind Farm", October 2005.

Preliminary dimensions of the turbines are not expected to exceed a maximum tip height of 170 m above mean sea level, with a nominal 105 m hub height and 130 m rotor diameter (details see Table 6-6). Details of the turbine technology are under development.

Table 6-6: Properties of representative current and future generation wind turbines for Greater Gabbard Offshore Wind Farm <sup>23</sup>.

Turbine Rated Capacity (MW)	Rotor Diameter(m)	Maximum Hub Height (m)	Rotation per Minute (rpm)	Minimum Air Gap at MHWS (m)
3	90	80	19 (max)	22
3.6	108	90	5 to 13	22
4.5	120	95	13 (max)	22
5 (and ~ 7)	130	105	7 to 12	22

***Selection of the foundation type: gravity, monopile, tripod:***

The environmental statement presents three options for foundations: driven steel monopile, driven steel multi-pile and concrete gravity base.

The installation of the driven monopile support structure option is expected to take between 4 and 6 hours. For a multi-pile structure with 3 piles, the time is expected to be 2-3 hours for each pile. The pile will have a maximum wall thickness of 95 mm, a weight up to 775 t and ground penetration will be 45-50 m below mudline. The predicted underwater sound power level for a 6.5 m diameter pile is predicted to be 288 dB re 1µPa @ 1 m, although the final level will depend on pile thickness, impact energy and ground conditions. The airborne noise emissions (sound power level) during piling are expected to be 137 dB(A).

The installation of the concrete gravity base starts with removing the tip of the seabed to a level where undisturbed soil is encountered. A excavation depth of 2 m is assumed. Stone will be deposited into the hole to form a level base. A crane barge will be used to install the concrete gravity base, which has width at base of 36 m, a concrete mass of 4'600 t and will be weighted with 11'500 t of sand/stones.

The volume of scour protection material is estimated to 1'432 m<sup>3</sup> per monopile and 2'847 m<sup>3</sup> per gravity base structure.

The final layout for Greater Gabbard is not yet decided, because not all information is available at present. The following principles will be followed:

- The co-ordinates of the two turbine array areas, interconnecting cable corridor and export cable route are fixed.
- Within these areas, there will be specified no-build / restricted-build areas (around known archaeology, sandbanks and cable crossings).
- Minimum distances between the turbines 650 m for energy yield reasons.
- Positions of the transformer platforms and the wind turbines may be moved to account for differing electrical connection designs.

***Grid connection***

Greater Gabbard Offshore Winds Ltd considered three grid connection locations: Bradwell (in Essex), Bramford and Sizewell (both in Suffolk). Sizewell was selected because of its sufficient spare capacity in the network and because it posed the shortest route to shore. In addition to few biological designations and top economics, no new permanent overhead lines or significant upgrades are required.

<sup>23</sup> ibid

The onshore components required to transmit the electricity generated by the wind turbines to the point of connection with the electricity transmission system, as well as the installation of such components, are described in detail in the environmental statement (cable landfall, cable jointing bays, cabling to connect the cable jointing bays to the onshore electrical substation, temporary 800 m single circuit overhead line diversion, substation features with up to four 400/132 kV transformers and 400/132 kV switchgear).

Up to four offshore transformer platforms collect the cables and transform the turbine interconnection voltage to potentially 132kV for transmission ashore by up to four export cables (cable length approximately 42 km, see Figure 6-1). Data from two geophysical surveys, a shallow geotechnical survey and grab samples were used to select the cable route.

The total length of inter-array (potentially 33 kV) cables at the Greater Gabbard Offshore Wind Farm is around 200 km (configuration depending on the final turbine layout, weight of cable in air is 35 kg / m, buried depth 1,0 m).

The Inner Gabbard and the Galloper arrays will be linked by (potentially 132 kV) cables (weight 61 – 77 kg / m, buried depth 1 – 1,5 m).

### **6.3 Installation and operation phase**

Greater Gabbard Offshore Winds Ltd aims to start offshore installation in 2007 and commence operation in 2009. Details of the planning are summarised in the environmental statement. They are not cited here.

### **6.4 Lessons learnt**

500 MW offshore wind farm Greater Gabbard is scheduled to go online in the year 2009.

The Greater Gabbard project and other offshore wind farms in Rounds 1 and 2 have strong political support in the United Kingdom. Official papers and statements emphasise the general political support for renewable energies and climate protection: Government White Paper “This Common Inheritance” (1990), The Royal Commission on Environmental Pollution report “Energy - the Changing Climate” (June 2000), Climate Change Programme (November 2000) and Energy White Paper “Our Energy Future - Creating a Low Carbon Economy” (2003) and Statement of Prime Minister to Parliament on 11 July 2005 at the G8 Summit at Gleneagles.

Greater Gabbard Offshore Winds Ltd (a joint venture between Airtricity Ltd and Fluor Ltd) has elaborated an ambitious strategy to involve stakeholders. High public acceptance is targeted, so information regarding the environmental and technical details of the wind farm have been published in the environmental statement. Communication is organised by an project briefing to local and regional consultees, pre-application briefing for officers and members of relevant councils, a project brochure, a public exhibition and a very informative website ([www.gretergabbard.com](http://www.gretergabbard.com)).

The project team has proven track record in wind farm projects, including the offshore wind farm Arklow Bank in the Irish Sea. Experiences will be brought forward to the Greater Gabbard project.

Greater Gabbard Offshore Winds Limited substantiates the wind farm with the need to reduce emissions of greenhouse and acid rain gases and to move towards a more sustainable future. The economy of east England will benefit from the £ 700 million project.

The distance from shore (23 km) reduces the likelihood of visual impact. The site has low maritime recreation usage. No significant bird concentrations in the immediate vicinity of the site are expected.

Greater Gabbard Offshore Winds Ltd proposes mitigation measures for possible environmental impacts and risk reduction measures for ship collision and accidents.

Greater Gabbard Offshore Ltd published an environmental statement in October 2005. The scope of the Environmental Impact Assessment (650 pages) covers the whole project (offshore and onshore works). The period from commencement of the first phase of construction, through the operational phase, to completion of operations and decommissioning is described in detail, which will help speed up the planning and implementation process.

## 7 Horns Rev (Denmark)

### 7.1 General

The first wind farm built in the open waters of the North Sea is the Horns Rev wind farm, located on the Danish west coast close to Esbjerg harbour (see Figure 7-2 and Figure 7-1).

Horns Rev was part of the Danish Offshore Action Plan established in 1997, pointing out five offshore areas for wind farm installation. Based on feasibility studies for each of the sites, it was decided to install a demonstration project at each location. At that time, a vision for the development of 4,000 MW of offshore wind power in 2030 was declared. The utility companies Elsam and Eltra were required by state decree to jointly build the Horns Rev wind farm. According to this decree, Elsam - as a production company - was requested to build the offshore wind farm and the internal offshore network, while Eltra - as a transmission company - was requested to build the offshore platform and the transmission grid. The ownership borderline is the medium-voltage side of the platform transformer.



Figure 7-1: View of the Horns Rev wind farm.

#### 7.1.1 Project description

Project description: Horns Rev	
Project name	Horns Rev
Country / region	Denmark (DK)
Owner / Investor	Danish transmission system operator Eltra and Denmark's largest heat and power producer Elsam
Developer	Elsam (wind farm, foundations, internal cabling) and Eltra (offshore transformer substation, sub-marine cable to land, onshore cable to general transmission grid)
Operator	Elsam
Location, geographical position	The offshore wind farm is located on the Danish west coast, close to Esbjerg harbour, south of the Horns Rev reef.
Area	20 km <sup>2</sup> (4 x 5 km)
Water depth	6 – 14 m
Distance to shore	The distance from the north-easternmost turbine to Blåvands Huk on the west coast of Denmark is approximately 14 km. The turbines are arranged in ten rows of eight turbines.
Operators website	Elsam <a href="http://www.elsam.com">http://www.elsam.com</a>

## 7.1.2 Technical data

Technical data: Horns Rev	
Wind turbine type	Vestas V80 – 2 MW
Number of turbines	80
Wind farm capacity	160 MW
Expected annual output	600 GWh/a
Rotor diameter	80 m
Hub height	70 m
Weight, blade	6.5 t
Weight, nacelle	79 t
Weight, tower	160 t
Weight, foundation	180-230 t
Total weight per wind turbine	439-489 t
Cut-in wind speed	4 m/s
Full power output from	13 m/s
Cut-out wind speed	25 m/s
Mean wind speed at 62 metres' height	9.7 m/s
Depth of water	6-14 m
Distance from shore	14-20 km
distance between wind turbines	560 m
Wind farm site	20 km <sup>2</sup>
Project costs	DKK 2 billion / EUR 278 million



Figure 7-2: Geographical map showing the location of the Horns Rev wind farm at Esbjerg.

### 7.1.3 Time frame

A tight time frame was calculated for the entire Horns Rev project. Generally, the schedule could be adhered to if procurement, assembly and installation were performed in due time. However, the commissioning phase had to be prolonged due to problems after installation. The individual steps of the overall project are listed in Figure 7-3, along with the planned time schedule. Due to the extended commissioning phase, the project was completed in mid 2003 instead in late 2002 as originally projected. The individual steps of the planning and installation phases are listed subsequently.

**Planning phase:**

- Initial planning was already covered by the early screening process for offshore wind farm locations, resulting in the Offshore Action Plan. The results formed the basis for the further approval process.
- In spring 1999, an extensive measurement programme was launched to survey wind and sea conditions. In May 1999, the first measurements were made and sea measurements commenced a short time later, in June of the same year.
- On 15 June 1999, Elsam and Eltra received permission to begin pilot studies for the project.
- In March 2001, the Danish Energy Agency approved Elsam’s and Eltra’s application for permission to establish a wind farm at Horns Rev in the North Sea, west of Denmark.

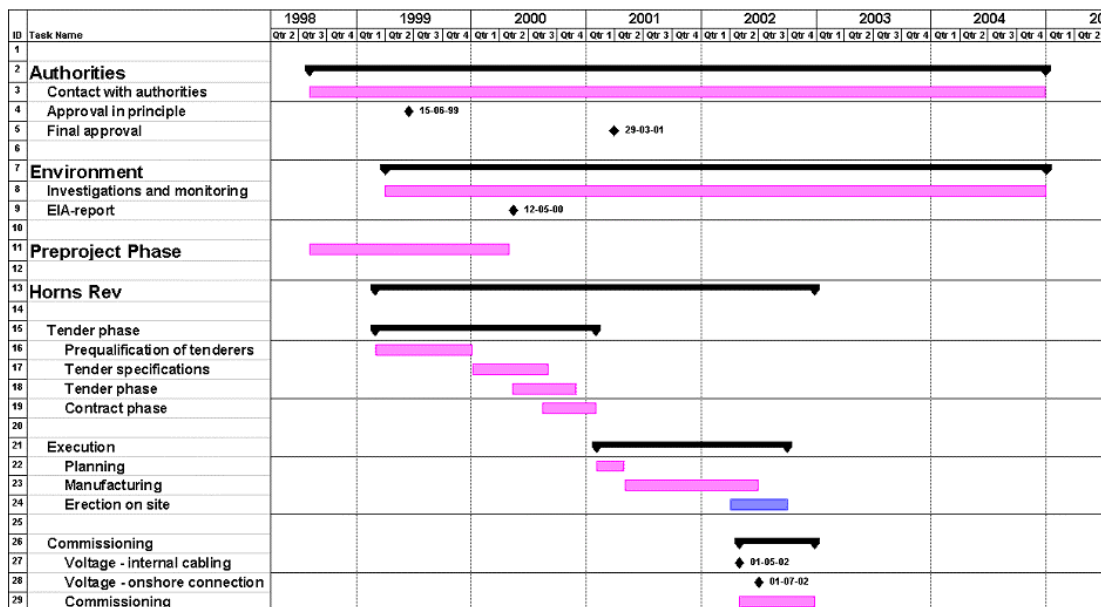

Figure 7-3: Timetable of the planning and installation process in Horns Rev.

**Procurement and installation phase:**

The planned time schedule for the overall installation process is depicted in Figure 7-4. The various installation works are performed largely in parallel, including production of the different components (towers, nacelle, rotor blades) and production and installation of the internal wind farm cables. Moreover, the process of procuring and installing the components of the offshore/onshore high-voltage connection is performed in parallel to the wind farm development.

Despite of these largely parallel processes, the individual site works, as described in Figure 7-5, had to be performed sequentially, due to the simple reason of the limited capacity of the contracted transport

and installation vessels. The plan was to install the 80 turbines in 6 stages of 14 (last stage 10 turbines) each. The single steps are as follows:

- First foundation pile driven on 30 March 2002. Transition piece fitted on the last foundation on 3 August 2002.
- First turbine erected on 7 May 2002. Last turbine erected on 21 August 2002. The 1200-tonne transformer platform was placed on the piles on 16 April 2002. All the piles were in place by Easter 2002.
- The 150 kV sub-marine cable was pulled up on the platform on 9 May 2002, and subsequently terminated in the 150 kV substation.
- First cable laid in park on 19 May 2002. Last cable laid between the turbines on 23 August 2002.
- The connection onshore went on line on 27 June 2002, performed by Eltra. The connection work was performed until May 2002.
- The first turbine commenced operations 29 July 2002. All the turbines were in operation by 11 December 2002.
- The wind farm was commissioned on 7 July 2003.

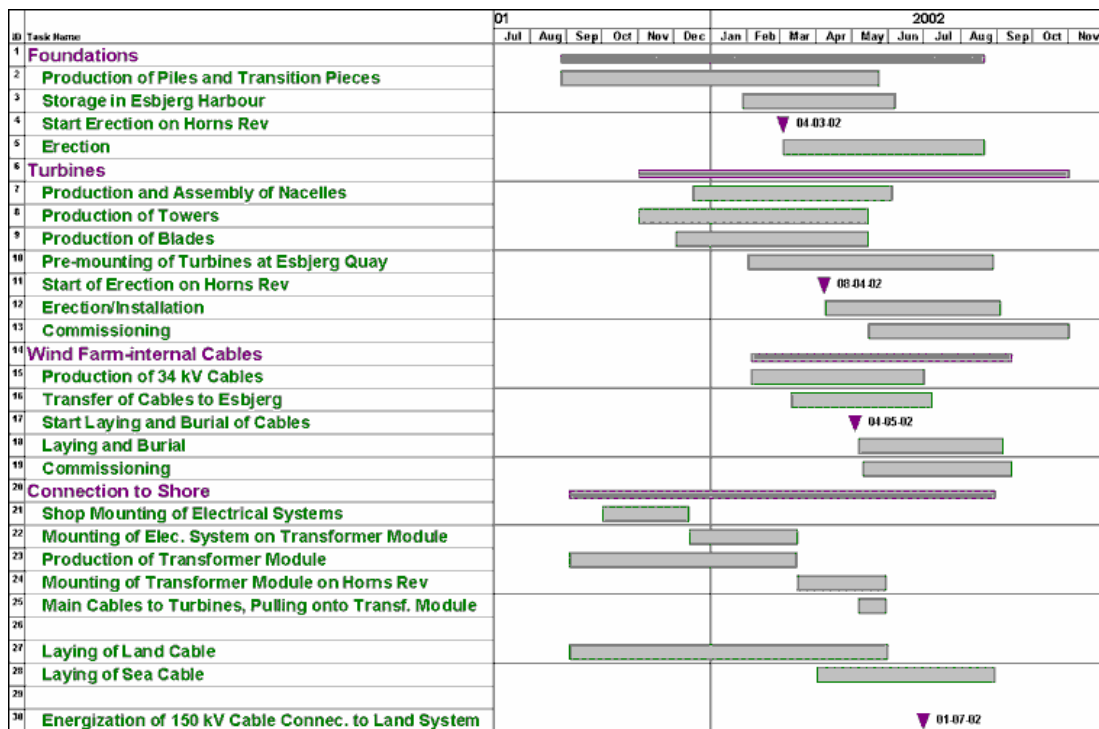

Figure 7-4: Timetable of the production and installation process only.

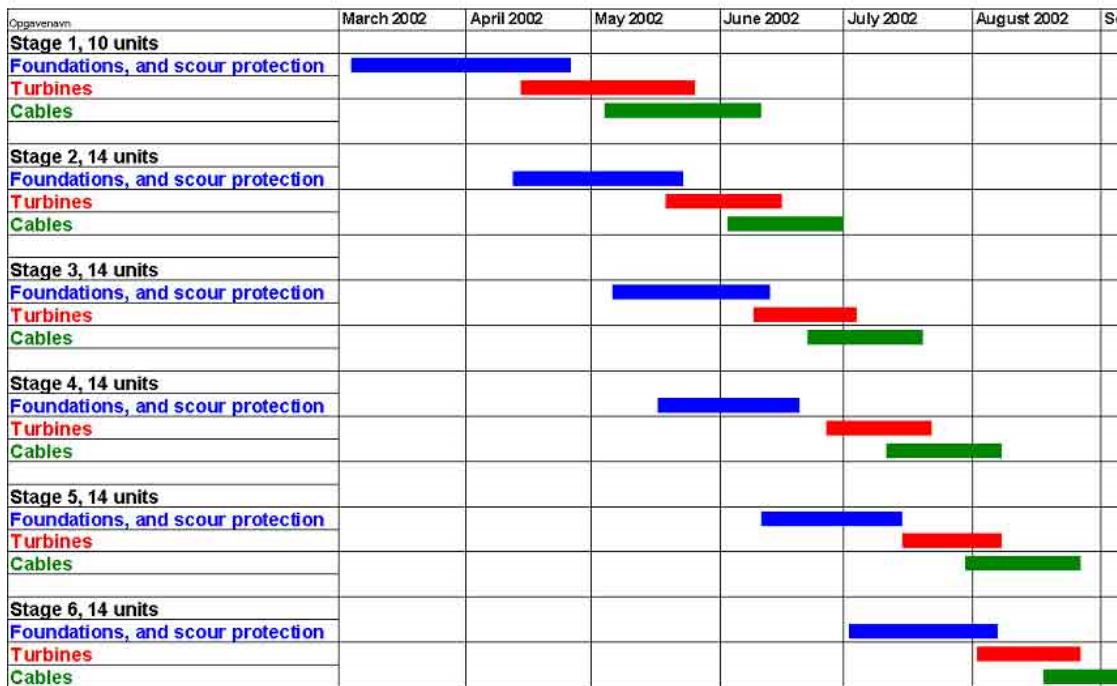

Figure 7-5: Time schedule for site works.

## 7.2 Project planning phase

### 7.2.1 Planning, approval and communication

**Project management:**

At the beginning of the offshore wind energy considerations in Denmark, a screening process for offshore wind farms was initiated in the early 80s. The outcome was a report pointing out the most suitable locations for offshore wind energy. A visual impact study was conducted in parallel. As a result of the initial planning, two test plants were planned and erected: Vindeby and Tunø Knob.

The result of the screening process was the establishment of an Offshore Action Plan, to investigate environment, economic and technical issues. Furthermore, a recommendation was made to set up five pilot offshore wind farms. The Ministry of Energy and Environment decided to install these first five large offshore wind farms and to set up the required economic framework (see Figure 2-1).

After the first two of these wind farms were installed (Horns Rev and Nysted), the newly elected government cancelled the further development of the remaining three.

A compromise was found between the new government and the wind industry: to build two extensions to the existing wind farms, Horns Rev 2 and Nystedt 2, instead.

For project management, Elsam established a project committee, formed from resources from Elsam and Elsam Engineering. This project committee was responsible for the complete planning, tender, contracting, installation and operation phases of the project. Elsam Engineering is a subsidiary of Elsam, responsible for most of Elsam’s engineering tasks. It has undergone several name changes and was formerly known as Techwise and Elsamproject.

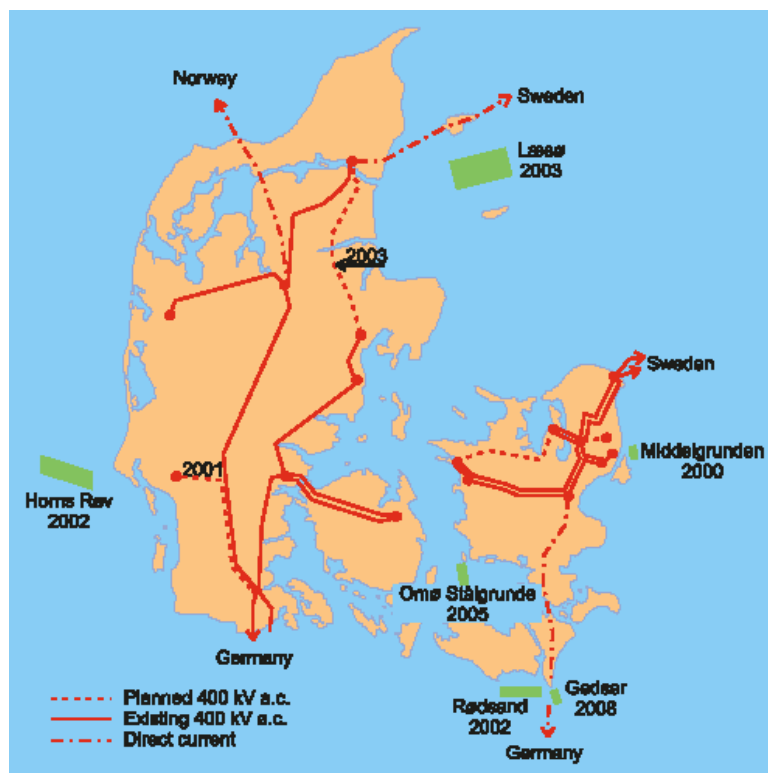

Figure 7-6: Locations for offshore wind farm identified in the national screening process.

### **Media strategy:**

Elsam basically has a strategy for developing and implementing renewable energy sources, and the Horns Rev project was promoted according to this strategy. Rules for press contact were laid down for the project team in the project manual. In the framework of the approval process led by the Danish Energy agency, a public hearing by DEA and Elsam was held with all local stakeholders and interest groups. Elsam participated in local information initiatives and also took the lead in informing more broadly about the project, including extending invitations to two press tours during the construction phase.

The main message was that Elsam had decided to invest in the first real, large-scale offshore wind farm because this business area had significant development opportunities. The effect of this information dissemination was great interest from Northern Europe and North America – from both public media such as TV stations and specialist media within the wind business.

### **Internal communication:**

As the complete management consisted solely of Elsam and Elsam Engineering, internal project communication could rely completely on existing, long-term organisation schemes within and between the companies. Generally, the project team was located at Elsam headquarters and site management was situated close to the site itself. Formal management was organised through regular project team meetings

### **Conflict management / mediation:**

The authorities managed discussions with external groups. Elsam was obliged to reach agreement with the fishermen regarding compensation. This was achieved through negotiation.

So far, mediation of conflicts has not been necessary. All conflicts that arose have been resolved through negotiations within the contractual framework. All contracts have an arbitration clause.

***Planning (legislative):***

The approval process for wind farm site was more or less already covered by the early screening process. This screening procedure dealt with all relevant issues in order to select the most appropriate sites for offshore wind farm installation. Accordingly, nature and environmental issues were covered, along with ship traffic, fishery and military demands and areas.

The main issues in the approval procedure were:

- an EIA report
- a public hearing
- planning consents with local stakeholders
- a building permit
- a production permit

Only one authority responsible for the approval process of the offshore wind farm including the sea cable: the Danish Energy Agency (DEA). DEA is responsible for approvals regarding power plants outside the coastline. DEA had to grant permission, after soliciting any concerns or objections from other authorities. The complete approval process was organised by DEA. The project team had only to deal with DEA; communication with DEA was good and problem-free.

As a result of the screening process, there were no conflicts in area utilisation. The previous screening process resulted in the identification of suitable areas with little or no interference with conflicting utilisations or nature and environmental demands. While a conflict for the Laesø site was discovered during the further planning process, no further conflicting utilisations were identified for Horns Rev. The only conflicting utilisation that had to be dealt with was fishery; compensation to fishermen had to be agreed upon. Also the visual impact of the Horns Rev wind farm was subject to public discussions.

No separate project planning or development plan was required specifically for the Horns Rev wind farm, as the previous screening process more or less already covered the spatial planning. The combined screening process was performed for the entire Danish coastline, to identify and document the most suitable and least conflicting areas.

***Type of expertises and investigations needed:***

Besides the investigations already performed during the previous screening process, investigations had to be performed for archaeological, environmental and safety reasons. Thus, investigations were performed to ensure that no archeologically important sites lied within the project area. All investigations and expertise desk studies required to cover the environmental assessment scope defined by the authorities were performed. The environmental impact assessment was obligatory, and covered the wind farm itself as well as the grid connection. A ship collision study was carried out as part of the EIA.

**Site investigation:****Standard of investigation programme**

In spring 1999 an extensive measurement programme was launched to survey wind and sea conditions. The first measurements were made in May 1999 and later, in June of the same year, sea measurement commenced. The investigation programme comprised:

Environmental impact assessment	1 year
Geographical investigation program	1 year
Oceanographical investigation program	Start June 1999, 2 years
Geological investigation program	3 months x 2 (preliminary, detailed)

**Environmental impact assessment**

All parameters defined in the EIA scope were covered:

- Sea floor flora and fauna
- Monitoring of fishes
- Monitoring porpoises
- Monitoring seals
- Monitoring birds

The investigations were carried out by research teams on vessels and airplanes, depending on the investigation issue.

**Oceanographical investigation**

The sea-measuring system consists of two wave riders, which constantly measure the movements of the sea surface. It also consists of an acoustic Doppler radar, which measures current, water depth, temperature and salinity from the seabed.

**Meteorological investigation:**

A square lattice mast equipped with measuring devices has been erected close to the reef, on a single ø1700 mm pile, as a stand-alone solution. It measures wind speeds and directions at four levels, temperature, atmospheric pressure, influx of light and registration of lightning. The measurements are made at the following four levels: 62, 45, 30 and 15 metres above DNN. A presentation of the stored and processed data is transferred from the database to an Internet-based Geographical Information System (GIS).



Figure 7-7: Measurement tower at Horns Rev (Source: ELTRA).

***Geological investigation:***

Geological investigations (cone penetration and seismic measurements) were performed to provide a reliable picture of the sea soil at the wind farm site. After the determination of the wind farm layout, eight drillings were made at each WT site, to secure a reliable basis for planning and offers during the tender process.

***Documentation of data:***

A presentation of the stored and processed data was transferred from the database to an Internet-based Geographical Information System (GIS).

## 7.2.2 Economics

### *Economic and financial issues:*

Costs	
Total cost (wind farm and connection to grid)	278 million €
Installation cost = CAPEX (foundations, internal cables and turbines)	238 million €
Production cost	O&M costs commercial confidential
Cost per turbine	2,97 million €
Internal grid cost	Included above
Offshore cable and conversion system cost	40 million € for the interconnection to the mainland grid
Onshore grid connection cost (from landing point to utility grid)	Included above
Specific costs:	without grid connection: 1488 €/kW with grid connection: 1738 €/kW
Estimated annual energy production	600 GWh/a
Capital and investment structure	Balance sheet financed
Amount and form of subsidies	EIA paid by the transmission system operator
Feed-in tariff and contract period	Elsam is guaranteed to obtain a selling price of DKK 0.33 per kWh for the power produced during a fixed number of full-load hours (42'000), equivalent to approx. eleven years of production + DKK 0.10 environmental premium.

The government asked Elsam to build and operate the Horns Rev offshore wind farm. In return, a fixed feed-in tariff would be paid. The amount of this tariff had to be agreed upon in negotiations between Elsam and DEA. The difficulties encountered during these negotiations were due to a difference of opinion regarding the necessity of company profits between a privately operating enterprise and a government agency acting in public administration.

### *Influence on employment:*

Influences on local employment are limited to the operation of a control room in Esbjerg, the staff for operation and maintenance of the wind turbines and for transport to the wind farm site.

### *Tax payments:*

Local tax payments are not expected by the local government.

## 7.2.3 Technology

### *Selection of the technologies:*

The selection of the technologies was based on the outcomes of the tendering and engineering process. Specifications were set for the turbine size and basic demands, but the selection was based on a wide range of technical, economic and financial security reasons.

The turbine selected was the Vestas V80, with a foundation formed by a single monopile. The monopile is made of a steel tube and is driven into the ground by a rammer. Figure 7-9 illustrates the turbine. The turbine spacing was chosen as 560 in both directions, based on a wind direction distribution that revealed no clear preferable orientation for the wind farm main spacing direction (see Figure 7-8). The wide distribution from Northeast to South demands an equal-distance spacing for both wind farm axes.

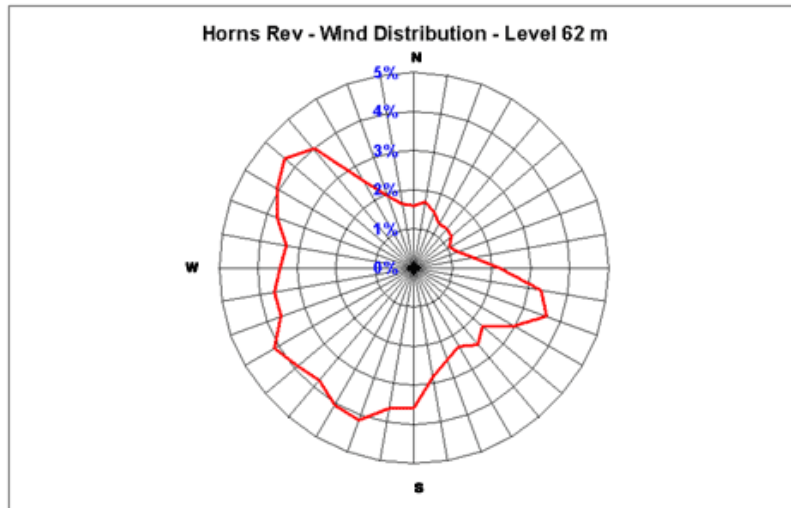

Figure 7-8: Frequency distribution of wind direction. The wide distribution from Northeast to South gives no main orientation for the wind farm spacing (Source Elsam).

#### ***Pre-testing of techniques:***

The Vestas V80/2 MW prototype turbine was planned to be tested in an onshore location prior to offshore installation. The prototype was erected in Tjæreborg on 5 December 2001. A test of an offshore location with a single turbine was not planned.

#### ***Grid connection:***

As described previously, the first demonstration wind farms in Denmark were selected according to various parameters. One of these parameters was the distance to the electricity transport network, to keep the projects easier and cheaper. Accordingly, because Horns Rev is one of these wind farms, the distance to the high voltage line is relatively short. The co-operation with Eltra, which was obliged by the government to build and own the offshore connection cable, was good and free of problems. The border between Eltra and Elsam property is the energy counter at the busbar of the medium-voltage level of the offshore transformer station.

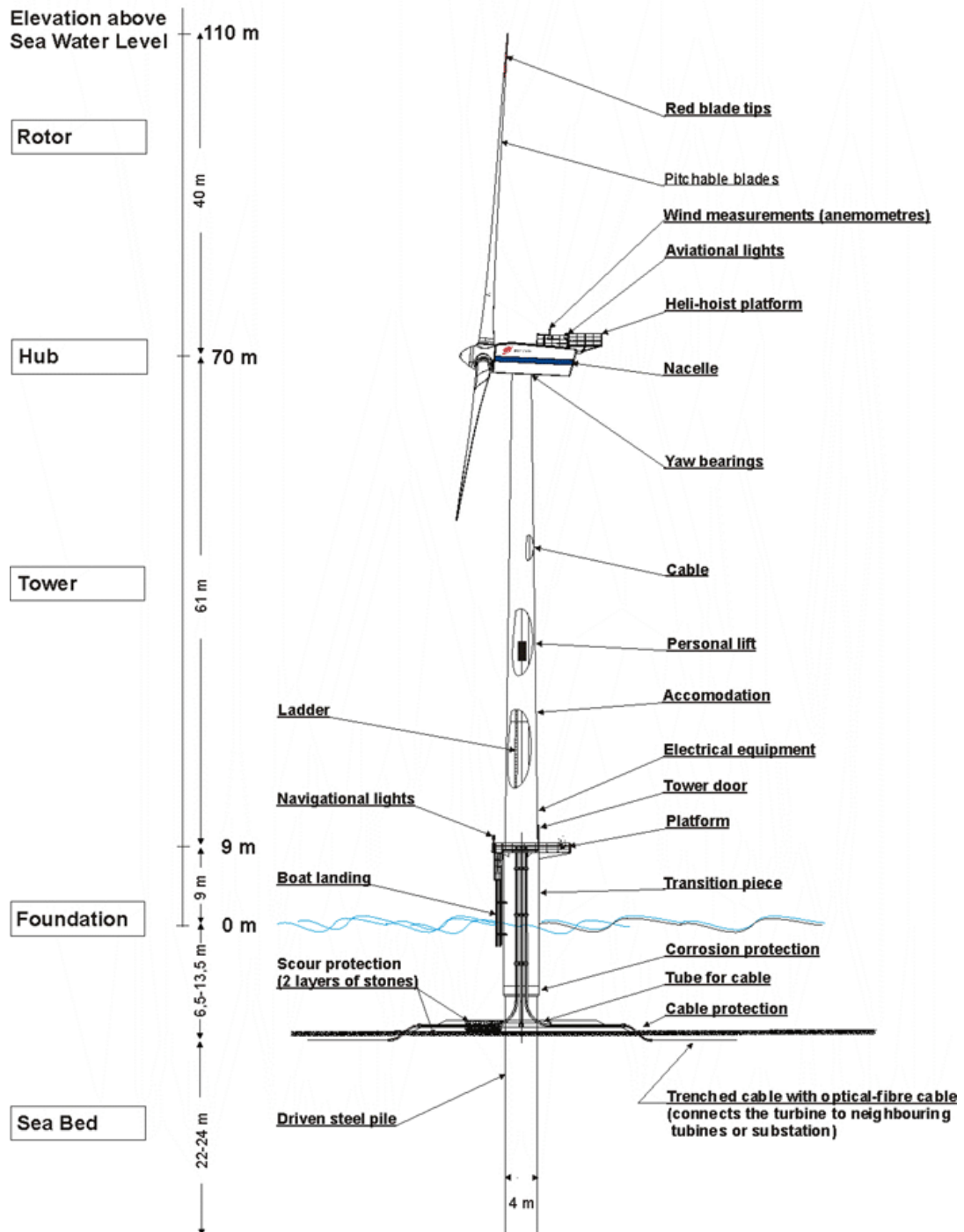

Figure 7-9: The Vestas V80 wind turbine selected for the Horns Rev offshore wind farm (Source: Elsam).

Due to the relatively short distance to land, a high-voltage –alternating current (HVAC) system was chosen as the grid connection system. The transfer voltage level was selected based on the voltage level of the given electrical network onshore; the offshore cable connects directly to the 150 kV network onshore. The medium-voltage level of the wind farm internal network is transformed to the high-

voltage level by a transformer station directly at sea, located in the wind farm area. The connection is made to the Karlsgaarde substation (see Figure 7-10).

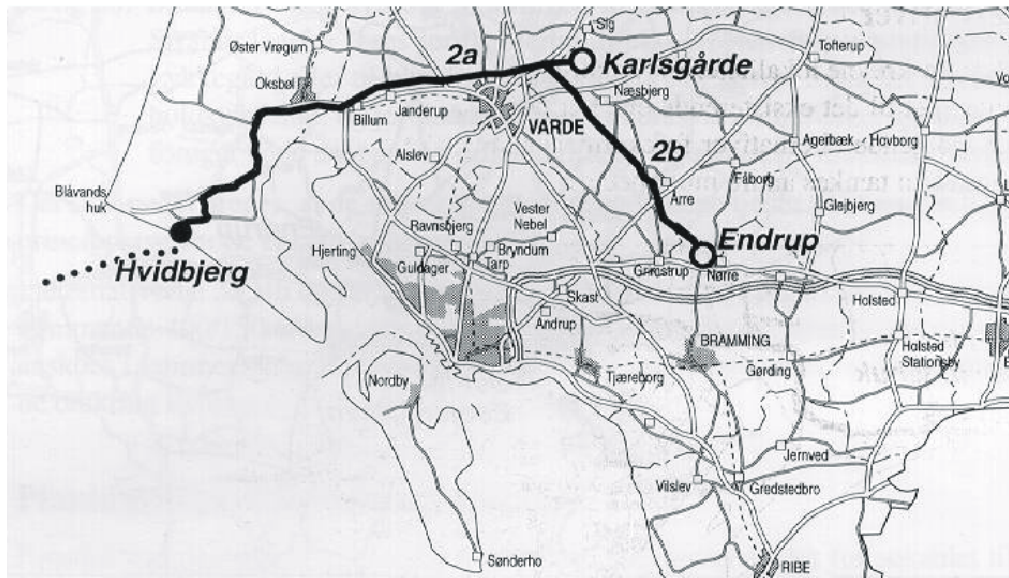

Figure 7-10: Route of power line on land (Source: ELTRA).

The schematic electrical diagram of the entire Horns Rev grid connection, from the medium voltage of the wind farm internal network to the high-voltage connection to point of common coupling to the onshore utility transport grid, is depicted in Figure 7-11. The individual components of the grid connection are described below:

*Transmission technology (HVAC, HVDC):* The connection of the offshore wind farm to the point of common coupling onshore is realised by a 3-phase HVAC connection at 150 kV (see Table 7-1). The sub-marine cable was, at the time, the first 3-core XLPE cable in the world for 150 kV (NEXANS, Norway). Each conductor consists of 630 mm<sup>2</sup> copper. The cable onshore is a 1200 mm<sup>2</sup> aluminium conductor with a 95 mm<sup>2</sup> copper screen. The three cables are laid in triangle and the screens are cross-bonded.

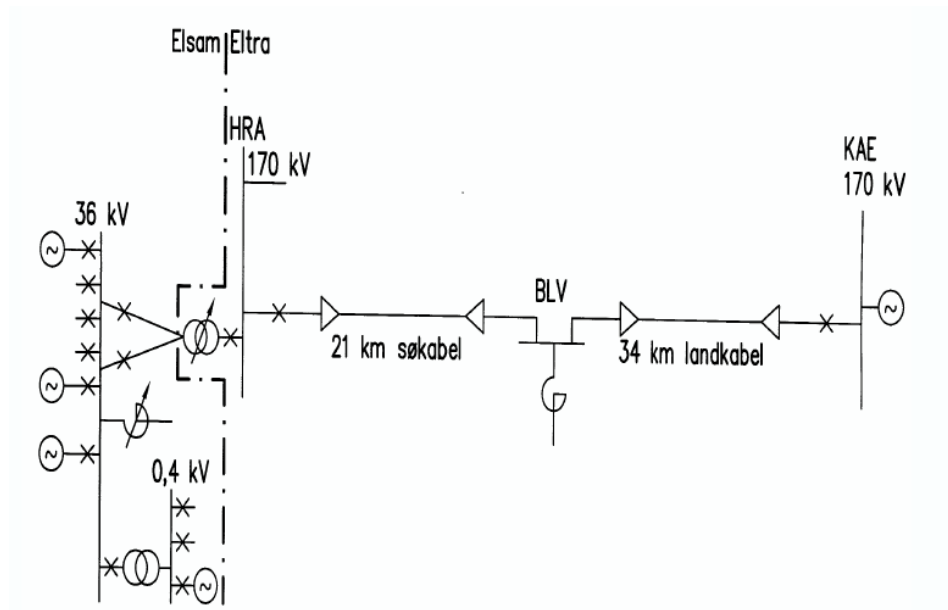

Figure 7-11: Schematic diagram of the Horns Rev grid connection, showing in example the single turbines, medium voltage switches, transformer stations from 36 kV to 170 kV, the 21 km sea cable and 34 km cable on land to the 170 kV connection point (Source: ELTRA).

*Wind farm interconnection:* The voltage level of the wind farm interconnection is at 36 kV medium tension. The cable interconnect the single turbines with the substation from 36 kV to 150 kV. The connection is split up into five groups, each group consisting of two branches with eight turbines each, see Table 7-2. The substation is located in the north eastern part of the offshore wind farm.

*Distance to grid:* The sub-marine cable leading from the substation to the coastline is about 21 km long and ends in a cable transit station 1200 m behind the coastline at Blåvand. From here 34 km land cables lead to the 150 kV grid and are connected via a normal open-air bay at the Karlsgaarde substation.

*Transformer/converter station:* All cables, wind turbines and onshore connection, are connected to the substation located northeast of the offshore wind farm. The substation is placed on three foundation piles, each with a diameter of 1-2 m. The platform consists of a steel structure of approx. 20 × 28 m, which is placed approx. 14 m above the sea surface and has a building height of approx. 7 m. The capacity of the transformer is 160 MVA, 36/150 kV. 36 kV and 150 kV switchgear.

*Cable route and depth:* The cables in the wind farm were laid from a cable ship. The cable was embedded into the seabed at 1,0 to 1,5 m.

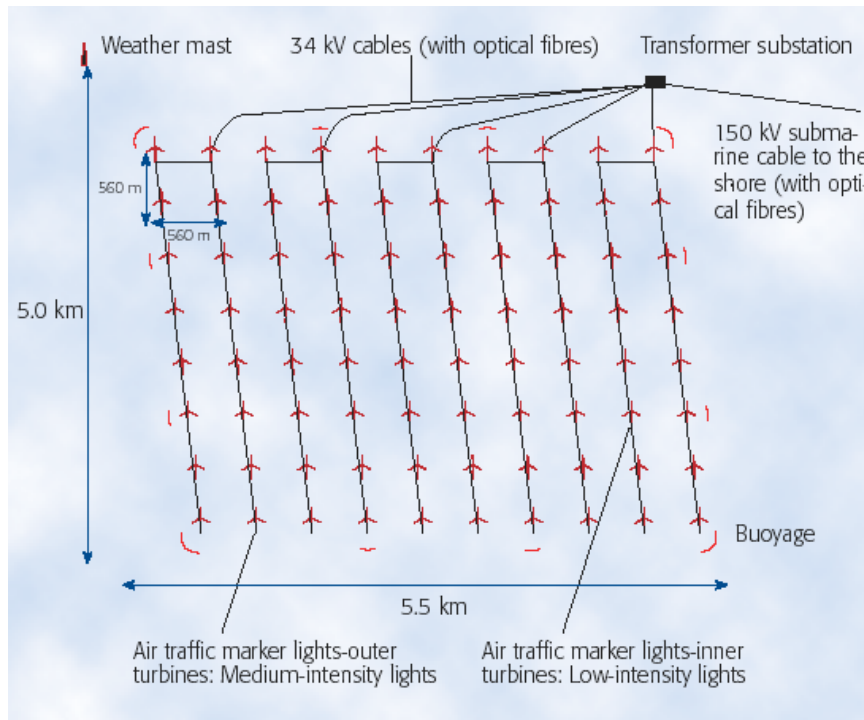

Figure 7-12: Cabling of Horns Rev wind farm (Source: Elsam).

Table 7-1: Technical data of the connection offshore wind farm to shore.

<b>150 kV Sub-marine Cable to Horns Rev</b>	
Connection between	Horns Rev-Blåvand
Producer	Nexans (Alcatel)
Place of production	Halden (Norway)
Diameter	192 mm
Weight	71 kg/m
Length of right-of-way	Approx. 22 km
Max. water depth	26 m
Trenching depth in seabed	1 m nominal
Trenching depth in surf	3 m nominal
Cable-laying vessel	H.P. Lading
Laying	Beginning of May 2002
Trenching	May/June 2002
The cable was the world's first three-conductor PEX cable for 150 kV	

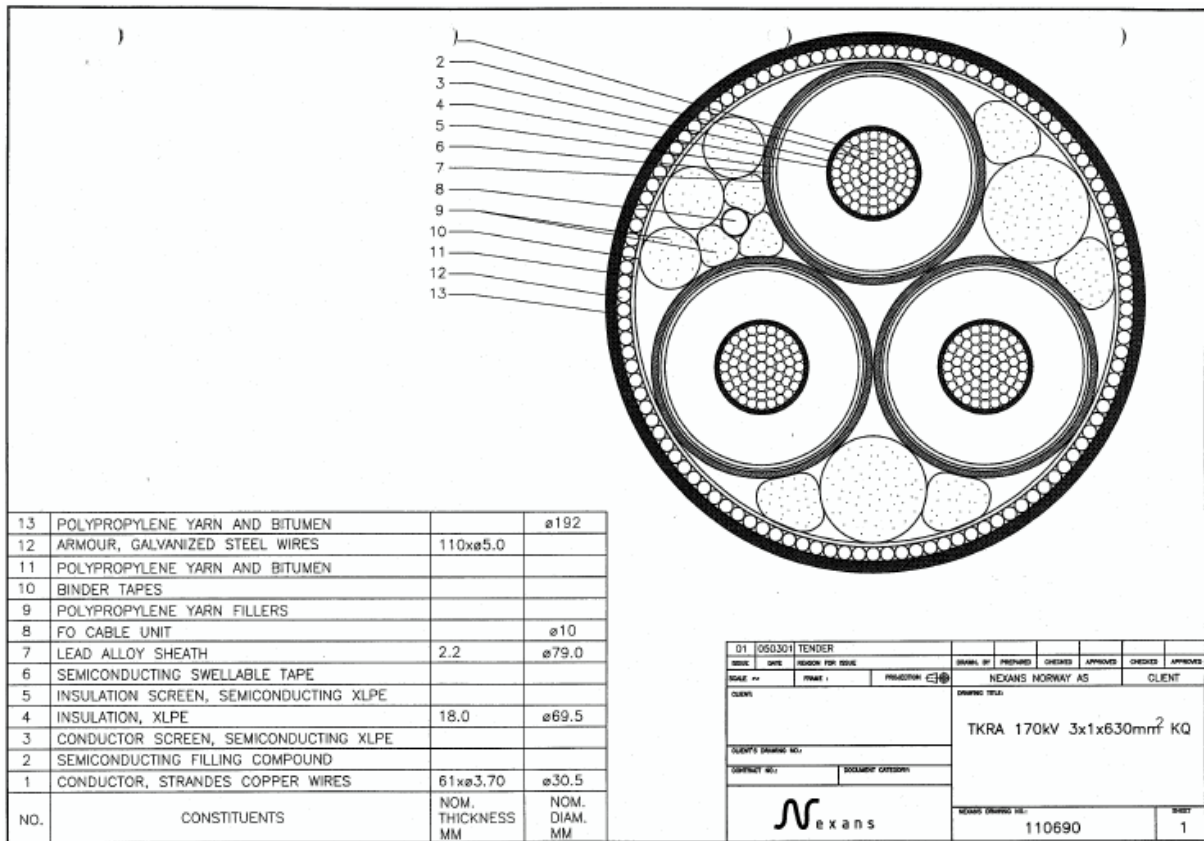

Figure 7-13: Sub-marine cable (Source: Eltra).

Table 7-2: Technical data of the grid connection onshore.

<b>150 kV Underground cable to Horns Rev</b>	
Connection between	Blåvand-Karlsgrårde
Supplier	ABB
Place of production	Karlskrona
Type	1200 mm <sup>2</sup> PEX-AL-LRT
Diameter	90 mm
Weight	8.7 kg/m
Drum length	1200 m
Drum diameter	3.0 m
Screen coupling	Cross-bonding
Laying configuration	Close tri-foil formation
Length of right-of-way	Approx. 34 km
Construction period	September 2001-May 2002

## 7.3 Installation and operation phase

### 7.3.1 Procurement

The project was designed on a multi-contractual concept, not as an Engineering, Procurement and Commissioning (EPC) project (turnkey). A turnkey project was deemed to be more expensive, as the turnkey provider has to take more risks.

To achieve lower costs for developing and building the offshore wind farm, the project was performed in a multi-contractual scheme. Therefore it was the task of the project manager to manage, negotiate and order the individual items separately.

The tendering process aimed to receive the offers for all the separate construction units at one time, so the tenders for all project components were conducted in parallel.

The difficulty arising from this process was the mutual interaction between the different project and construction parts. For example, the loads on a WT are strongly dependent on the technology selected for the turbine type. In turn, the turbine loads have a considerable impact on the foundation design, and the dynamics loads on the rotor and drive train lead to dynamic loads on the tower and the complete foundation structure. All this interaction must be considered in the separate selection and contracting process for the wind turbines and the foundations.

The first step in solving this complex process was a pre-tender phase, a first round with a limited number of selected manufacturers. After this first step, the remaining manufacturers were asked for tenders in a second round. The aim of this tendering process was to identify suitable suppliers at an early stage of the project. Finding the best time to determine suppliers is a tricky process, which has to balance the conflict between better competition and reliable technical solutions. Selecting a supplier later means getting a cheaper price. But selecting a supplier earlier means a better overall process for technical management and engineering, as the individual components from the different suppliers can be tuned to a better joint solution.

To allow an optimal solution, Elsam Engineering had to control the interfaces between the different suppliers and manage the complete engineering process. To determine the technical parameters at the interface from one project component to the other requires excellently skilled staff in the engineering company, as well as for the administrative management process. The management process for offshore wind farms is rather more complex than for onshore wind farms, but it is not as complex as building a conventional power plant.

One of the most challenging questions was the amount of weather risk that each supplier should share. Bad weather is, of course, the most unforeseeable and most obstructive problem. Compared to onshore wind farms, wind speed is more likely to hinder the installation of towers, nacelles and rotor blades. Moreover, high waves and rough waters have the potential to disrupt any part of the wind farm installation process.

### 7.3.2 Installation and grid connection

#### ***Erection:***

In the general installation concept, it was determined that Elsam and Eltra would perform the installation and monitoring work, but would also contract supply companies to at least deliver components, and perhaps also guide the transport and installation of the components.

The substation and the wind turbines were installed in separate processes. Different installation vessels were used for pile-driving, substation installation and wind turbine erection. The pile-driving tasks were performed using a jack-up platform from Ballast Nedam with a heavy-duty ram, to drive the

monopile into the seabed, see Figure 7-14. Turbine installation was conducted by the crane vessel “Ocean Hanne”, owned by the company A2SEA.



Figure 7-14: Pile driving (left) and installation of the transition piece (right) was carried out by jack-up platforms from Ballast Nedam (Source: Gunnar Britse).

Component	Contractor
Foundation construction and installation	Elsam contracted MTHS Entreprenør A/S
Tower construction and installation	Elsam contracted Vestas Scandinavian Wind Technology and A2SEA
Cable construction and installation	Eltra contracted Nexans
Transformer construction and installation	Eltra contracted Alstom
Responsibility for grid connection (on and offshore)	The sub-marine cable was installed by Eltra, which was in charge of making the produced power available to the grid. Triple-core 150 kV cables with sub-marine armouring was used. Land cable were ABB type.
Turbine construction and installation	Elsam contracted Vestas Scandinavian Wind Technology

The substation was installed by the “Asian Hercules”, crane hooked the 1,150-tonne substation and transported it to the Horns Rev site (see Figure 7-15).



Figure 7-15: Left: “Asian Hercules” delivering the 1200-tonne substation (Source: ELTRA). Right: The ready installed 36 kV to 150 kV substation (Source: Gunnar Britse). The medium voltage cables from the turbines are connected to this substation.

The offshore cable laying was performed in spring 2002<sup>24</sup>: “The cable ship Henry P. Lading was chosen for the cable-laying operation, as it could get closer to the coastline at Blåvand than any of the other alternatives. With the strong sea currents in mind, it was important not to have more cable than absolutely necessary laying on floats in the sea. The cable was pulled ashore on 7 May 2002, and the laying of the cable then took three days and it was pulled up at the platform on 9 May 2002 in the evening.”

The laying of the onshore cable lasted from September 2001 to May 2002.

During installation, a construction vessel destroyed one of the interconnection cables in the wind farm: the anchor hit the cable, which laid unprotected on the seabed. The costly repair was performed by a Dutch specialist company; the EUR 2 million repair costs were covered by insurance. This accident turned out to be the biggest event in the construction phase.

#### ***Harbour logistics:***

The supplier of the turbine foundations accomplished its task excellently, the company had gained vast experience during construction the Great Belt bridge. The logistics in the harbour were unproblematic, the company leased enough harbour space for their works and hired sufficient services.

The situation was quite different for the turbine manufacturer. Having no experience in this field, Vestas ordered harbour space which turned out to be



Figure 7-16: The crane vessel “Ocean Hanne” was used for turbine transport and installation (Source: Gunnar Britse).

<sup>24</sup> Offshore Work on the 150 kV Substation and the Sub-marine Cable, Eltra , 23.10.2003

far too small for the assembly volume determined in the project schedule. The harbour area (Figure 7-17) was used for assembly and preparation for shipment of towers, nacelles and rotor blades – as well as a harbour quay for loading the components onto the transport ships at the same time. It was originally planned to prepare four turbines at the same time and ship them together. Due to the bottleneck in the harbour logistics, however, only two turbines were shipped at a time.



Figure 7-17: Turbine assembly area in the harbour and shipping out of the harbour (Source: Gunnar Britse).

The offshore transport and installation was performed by offshore services provider A2SEA, Denmark. From the view of A2SEA, the most important lesson learnt lies in the underestimation of the onshore harbour logistics. An area of 5000 m<sup>2</sup> was planned for turbine installation. After installation commenced, it became readily apparent that a drastic enlargement was required: at least additional 10000 m<sup>2</sup>, and preferably 20000 m<sup>2</sup>.

In fact, the onshore harbour logistics turned out to be the biggest bottleneck in an otherwise smooth project process. One of the major outcomes is the recognition that harbour logistics should be planned and be fully contracted in all details far in advance of the installation. Another major learning factor was that for a harbour like Esbjerg, the work and assignments connected to an offshore wind farm project are seen as an unique business, which will not be repeated with the extension of the installation phase in subsequent years. Therefore, as long as only a limited number of turbine installations is expected for a harbour, the wind farm installation is a secondary-priority business compared to long-term activities such as container shipping and other continuous naval business.



Figure 7-18: Installation of tower (left) and rotor blades (right) (Source: Gunnar Britse).

***Grid connection and transformer station:***

A large floating crane was used to perform the pile-driving for the transformer platform. After a template was placed and the protective layer of stones on the seabed was laid out, piling operations started. However, the weather turned out to be so rough that it was impossible to drive the piles vertically within the required tolerances. So operations were stopped and a new set-up with a jack-up was planned for the early spring of 2002.

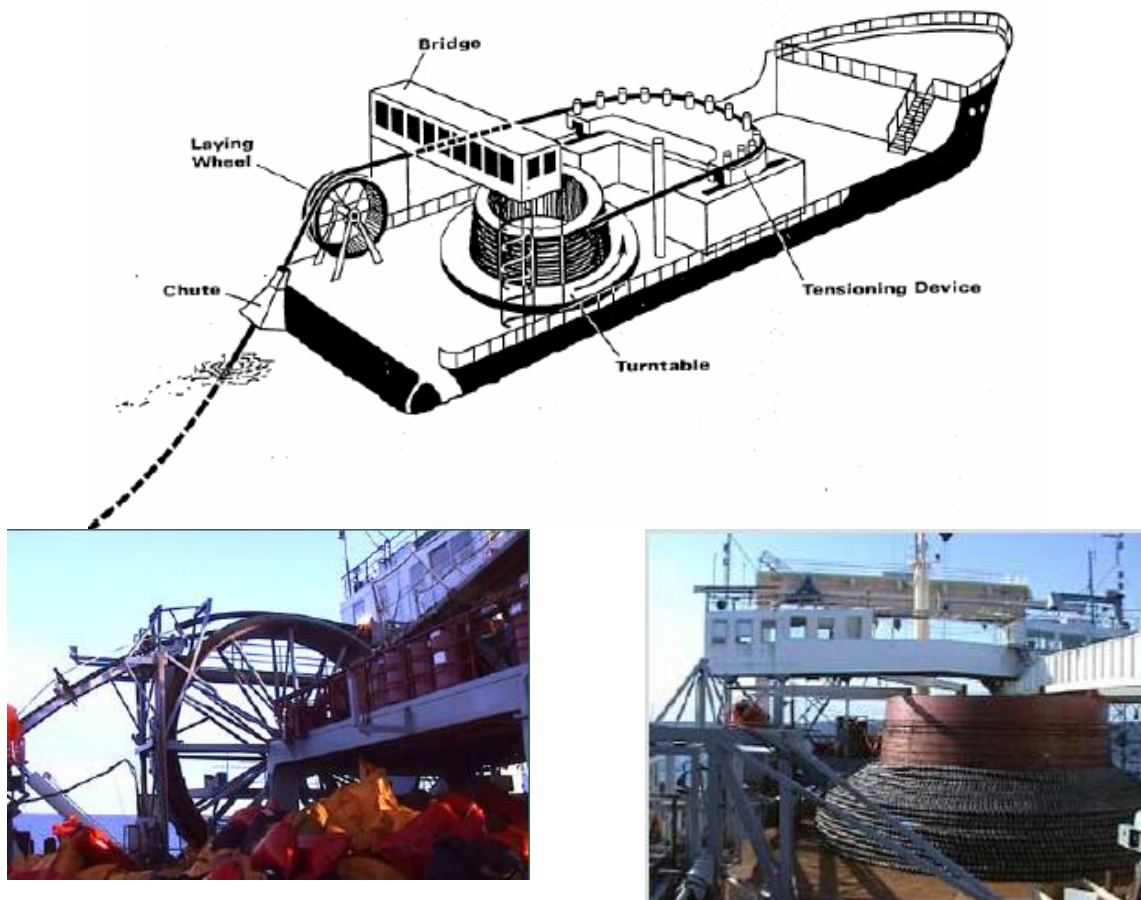

Figure 7-19: Sketch and pictures of the cable-laying ship "H.P. Lading"<sup>25</sup>.

### 7.3.3 Commissioning

The commissioning of the Horns Rev offshore wind farm was planned for the second half of 2002, by December. Due to multiple problems after installation of the complete number of wind turbines, the commissioning was extended to a period from November 2002 to July 2003. The main reason for the long commissioning period was the insufficient assembly of the turbines before shipment and installation. Due to the rather tight installation time schedule, which both developer Elsam and manufacturer Vestas wanted to follow, onshore assembly and testing of the turbines was not performed to a sufficient extent.

The turbine supplier was responsible for the testing procedures, which were supervised by the project management team.

The selected wind turbine type, the offshore version of the Vestas V80, was still in a prototype stage at the time Horns Rev was installed. Vestas had still to make improvements to the turbines during assembly and installation. These improvement works led to a considerable delay in wind farm installation. Not all of the nacelles shipped were in the final assembly condition. But both Elsam and the manufacturer took care to keep the planned and agreed time schedule.

<sup>25</sup> JD-Contractor/Jydsk Dykkerfirma Aps

Due to these reasons, the commissioning phase, which was planned to be finalized at the end of December 2002, had to be extended to June 2003. A considerable amount of work had to be done to do the final assembly work at the already-installed turbines. Moreover, the contractor did not plan the commissioning phase sufficiently, which contributed a further delay.

During the commissioning process, the grid connection cable onshore failed around Christmas 2002, leaving the wind farm at black-out for 14 days. This further delayed the commissioning process, along with other faults in the wind farm SCADA and the turbine controller software.

The network failure, leading to a standstill of the turbines for 14 days, caused further problems. Standstill marks in the gearboxes could be identified in 8 of the installed turbines. As the specification for the turbines demands for a period of no power – and thus a possible standstill for one month – the turbine manufacturer was required to cover the costs of this fault. A technical solution was found in case of future blackouts of the network connection. It enables the turbines to run slowly at idle speed, to prevent damage to the gearbox and drive train.

### 7.3.4 Operation

Selecting a prototype with only a short trial period turned out to be a problem. The new turbine concept (variable rotor speed) and enlarged size became a problem, as did the transformers.

During the first year of operation, the insulation of the generator windings turned out to be insufficient. The increased demands of a marine environment had not been met.

To avoid the major effort needed to replace turbine components (not to mention complete turbines), the selected turbines needed to demonstrate a sufficient trial period and a first low-volume production series of the turbine type. In particular, the demands of the offshore environment had to be tested and met thoroughly.

The official start of operation was scheduled for 15 December 2002, but in fact became 11 July 2003 due to the prolonged commissioning period. Quality problems turned up for a number of components in the individual turbines: rotor blades, gearboxes, transformers and generators. A significant number of individual turbine transformers failed in the autumn of 2003; wind farm availability sank to 50 %. It turned out that the transformer winding insulation did not meet the required standards and the transformer windings failed due to the highly corrosive climate. In December 2003, a decision was taken to exchange all of the turbines transformers and replace them with a Siemens type. The exchange was performed between December 2003 to February 2004. In addition, the air ventilation system was changed from bottom of the nacelle to the middle, to minimize the exposure of the transformer to outside air.

After two years of operation, the influence of corrosion seems to be comparatively low. The quality of the delivered components has to be high to reduce the influence of the rough environment to on turbine reliability. For offshore wind farms, where access can be quite difficult at specific times, the reliability of the components must be as high as possible.

Severe generator problems occurred in 2004. To solve this problem, as well as problems with the rotor blade coating and the lightning system, it was decided to dismantle the turbine rotors and nacelles and ship them onshore. The nacelles were overhauled in Ringkøbing, the rotor blades were brought to Nakskov, Lolland for improvement of the lightning systems. The plan was to have at least 30 turbines running all the time, but in fact only 4 turbines were operating in September. Dismantling of the turbines went much faster than calculated, while the erection was delayed. All turbines were in operation again by mid-December 2004. The availability of Horns Rev has been above 96% since January 2005, a remarkable figure for an offshore wind farm.

## 7.4 Lessons learnt

### 7.4.1 Approval process:

In the frame of the approval process led by the Danish Energy Agency, a public hearing by DEA and Elsam was held. Environmental issues did not turn out to be problematic at this hearing, but tourism issues did. The tourist organisations and local municipality demanded that offshore wind farm be further out in the sea. At the end of the discussions, DEA decided to refuse these arguments. The tourist organisations then elected to turn positive towards offshore wind energy and include it in their tourism strategies. There are no complaints today.

The early integration of stakeholders can support a more fact-oriented and less emotional discussion with the involved parties.

### 7.4.2 Planning:

No major problems on issues covered by the screening process turned up later for Horns Rev and Nysted. This might have turned out different for the Laesø wind farm site if the planning had been followed up, due to bird habitats found in the respective area.

No major delay occurred during the planning or construction phases. The original plan was to build in 2001, in fact it was ready by 2002.

No major changes had to be made in the time schedule. The plan was:

Year 1: EIA

Year 2: Tendering, procurement, engineering and contract negotiation

Year 3: Manufacturing

Year 4: Installation and commissioning.

The schedule could be kept, but commissioning lasted six months longer than planned.

### 7.4.3 Site investigations:

- Meteorological measurement was unproblematic and showed good availability.
- Wave measurements showed small difficulties, presumably collisions with fishing gear.
- The results of energy yield assessment were quite good based on the measurements.
- The prediction system for wind energy production on a 48-hour basis is sufficient.
- Some acoustic measurements were destroyed, presumably on purpose

### 7.4.4 Tendering process:

As the Horns Rev offshore project was not an EPC, the determination of suppliers for the different farm components and trades had to be done by the owner, Elsam, recommended by the project manager Elsam Engineering. The tendering process for wind farm manufacturing and installation is quite more extensive, but it enables complete risk management by the investor itself.

The selection of a multi-contractual project concept had a clear economic advantage over the Engineering, Procurement and Commissioning (EPC) concept, where the complete turnkey project is delivered to the investor by one contractor or syndicate. From the investor's point of view, the clear advantage of the EPC is that it minimises risks. But because the turnkey contractor has to cover the entire project risk, the full costs to cover these risks are included in the turnkey contract. The increase in project cost for risk coverage is estimated at around 20%. This was learnt from the first offshore

wind farms in Denmark, and the realised offshore wind farm projects in the UK show the same. Currently it seems there will also be a move from the EPC contracts to multi-contractual concepts in the UK, with the aim of reducing the high project costs.

In the multi-contractual concept, the risks are shared between the different contractors and the investor. The investor's task is to manage and negotiate the risk sharing between the different parties. The investor can influence the project costs by taking on more or less risk himself.

Elsam Engineering is appointed to be the owner's engineer for one of the next projects, the Burbo offshore wind farm in Great Britain, outside Liverpool. With the experience gained from the Horns Rev wind farm, Elsam Engineering will basically perform the tender process in the same way, with the same concept as for Horns Rev. In addition, discussions with investor and suppliers are more or less the same. The basis for reliable work is a good understanding of the risks inherent in the different components of the project. As a result of the Horns Rev project, there is now a better understanding of these risks. Each contractor understands the weather risk for its project component better than anyone else, so the most economic way is to demand that every contractor directly bears the majority of its own weather risk.

The target is to demand that contractors take over risk to a large extent. In case of Burbo, most of the weather risk was taken over by the individual contractors: it was not interesting for the investor to bear a larger risk, the financial bonus for taking over the weather risk was simply too low.

#### **7.4.5 Manufacturing:**

Selecting a wind turbine type which is still in the prototype stage can turn out to be far too problematic. In case of Horns Rev, improvements had to be made to a considerable extent at a very late stage, and even after installation.

Both Elsam and Vestas were very much determined to follow the agreed-upon time schedule for turbine installation. As a matter of fact, the manufacturing and assembly of the new turbine type was accompanied by problems which by all rights should have led to a delay in installation. The decision to install the turbines according to the planned schedule meant installing turbines which had not been completely assembled and tested.

From today's point of view, a decision to postpone the installation for turbines that had not been readily assembled would have resulted in less effort. The job of finalising the assembly offshore is far more expensive than doing this work onshore, and may also result in diminished assembly quality. The major lesson learnt is that the assembly and final check of each turbine should be performed onshore, even if this means delaying the installation process. The technical benefits of a successful complete assembly are greater than the disadvantages associated with delayed commissioning.

#### **7.4.6 Installation and commissioning:**

In the project planning, the main difficulties were foreseen in the offshore logistics. In fact, it turned out that the offshore works were planned, prepared and performed in a professional way by skilled offshore companies.

The main problem that turned up during the most difficult task, the installation phase, was that harbour logistics were insufficiently planned and prepared. Thus the onshore planning caused many more problems than the offshore planning, due to the simple fact that the turbine supplier were focussed on the manufacturing and installation tasks, and underestimated the onshore pre-installation works and furnishings required.

In retrospect, the strong efforts to adhere to the planned time schedule must be considered as the main cause for the problems during the commissioning phase. The turbine assembly was not performed sufficiently due to time pressure; the idea was to complete missing or incomplete work after installa-

tion at sea. But it turned out that completing the work at sea was much more expensive than it would have been onshore, as was suggested by the manufacturer and by project management. In retrospect, a prolongation of the assembly period onshore and a shift of the installation and commissioning period would have been less problematic.

In future projects, the task of commissioning the turbines will receive greater importance, as will tests of the ready-assembled turbines onshore, before they are prepared for shipment. The primary target will be a functioning turbine, not merely an installed one.

#### **7.4.7 Operation:**

The selection of a prototype with only a short trial period turned out to be a problem. The new turbine concept (variable rotor speed) and enlarged size proved difficult, as did the constraints of a marine environment.

## 8 Nysted (Denmark)

### 8.1 General

#### 8.1.1 Project description

In 1995 a workgroup under the Danish Energy Authority pointed out four areas in Danish territorial waters suited for offshore wind farms. This led to an agreement in 1997 between the Minister of Energy and the two major Danish utility companies, Elsam and Elkraft (later ENERGI E2), to establish five demonstration projects with a total capacity of 750 MW. The second to be completed was the Nysted Offshore Wind Farm, developed by ENERGI E2.<sup>26</sup>

Table 8-1: General project description of Nysted Offshore Wind Farm.

Project description	
Project name	Nysted Offshore Wind Farm
Country/region	Denmark, Baltic Sea
Name of owner	Joint venture (ENERGI E2 50%, DONG 30% and the Swedish Sydkraft 20%) SEAS Transmission A/S is the owner of the grid connection (the substation at sea and the cabling from the substation and onshore cable to national grid)
Name of developer	ENERGI E2
Name of operator	ENERGI E2
Location	South of the coast of Lolland, Denmark, Baltic Sea, nearest town: Nysted (approx. 10 km)
Area	24 km <sup>2</sup>
Water depth	6-9.5 m
Distance to shore	9 km
Operator's website	<a href="http://www.e2.dk">www.e2.dk</a>

<sup>26</sup> POWER - Offshore Wind Supply Chain Study for Denmark - Supply Chain in a Globalized World, Final Report – September 2005

### 8.1.2 Technical data

Table 8-2: Technical data of Nysted Offshore Wind Farm.

Technical data	
Total installed capacity	165.6 MW 480 GWh / year <sup>27</sup>
Number of turbines	72
Name of turbine manufacturer and rating	Bonus A/S 2,3 MW turbine
Hub height	69 m
Blade length	41 m
Rotor diameter	82,4 m

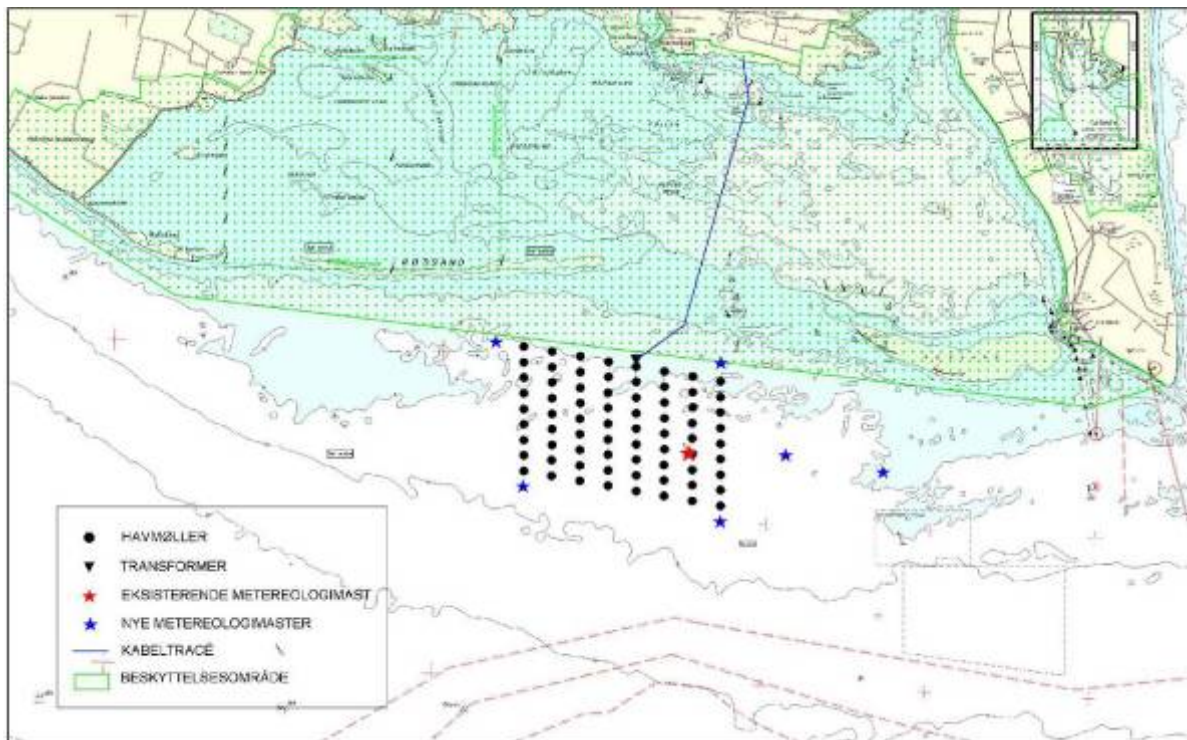

Figure 8-1: Map of area of Nysted Offshore Wind Farm<sup>28</sup>.

### 8.1.3 Time frame

The Danish government and production companies reached an agreement in 1998 to establish a large-scale demonstration programme for offshore wind. The objective of the programme was to investigate

<sup>27</sup> Bimonthly Magazine - September/October 2004

<sup>28</sup> Steffen Andersen, Charlotte Boesen "Environmental issues concerning offshore wind farms experiences from the Horns Rev and Nysted Offshore Wind Farms", EWEC 2004, London

economic, technical and environmental issues to enable large-scale offshore development and to open up selected areas for future wind farms.

In 1999 the Danish Energy Authority approved the installation in principle, and preliminary surveys and planning of *Horns Rev* and *Nysted* was initiated.<sup>29</sup>

In summer 2000, the environmental impact assessment for the wind farm was submitted to the authorities, and the application was approved in 2001.

The offshore construction work for foundations commenced at the end of June 2002.<sup>30</sup> The production and installation of foundations was carried out according to schedule. Beginning with the contract award in March 2002, all foundations were in place by the summer of 2003 and ready for reception of the wind turbines.<sup>31</sup>

The first turbine was installed on 9 May 2003. The first turbine started operation on 12 July 2003. The last turbine was installed and connected to the grid on 12 September 2003. Commissioning was finalised on 1 December 2003.

## 8.2 Project planning phase

### 8.2.1 Planning, approval and communication

ENERGI E2's fundamental requirements were full access to the design process and full responsibility resting with the manufacturer<sup>32</sup>. ENERGI E2 aimed for a good working relationship with the manufacturer from design to pre-installation and from erection to commissioning. While the manufacturer bore full responsibility for the design, it still had to be willing to discuss details of the concept with ENERGI E2.

#### **Project team:**

The offshore Nysted wind farm is owned and planned by two teams: *ENERGI E2* was responsible for the wind farm. *SEAS Transmission* was responsible for the transformer station at sea and the cabling from the substation to shore at *Radsted* (Lolland).

*SEAS Distribution* advised the project (see Figure 8-2) and was responsible for overall project management.

*Per Aarsleff A/S* was contracted by ENERGI E2 under a 'design and construct contract' to prefabricate and install 73 concrete foundations (72 foundations for 2.3 MW wind turbines and one foundation for a transformer substation). *Per Aarsleff A/S* and the Dutch company *Ballast Nedam* delivered the foundations in a joint venture. *COWI* designed the offshore wind turbine foundations.

*Pirelli* delivered the grid connection from the substation to the shore (132 kV cable) and reinforcements of the power grid crossing *Guldborgsund* and *Storstrømmen*.

*ABB* delivered the collection grid (33 kV cables) between the wind turbines and the transformer station, as well as the land cables from *Vantore Strand* for the connection to the power grid at *Radsted*.

*ABB* delivered the SCADA system for overall control and regulation of the wind farm.

*Bladt Industries* built the substation.

---

<sup>29</sup> *ibid*

<sup>30</sup> Aarsleff "Offshore wind farm at Rødsand", Abyhøj, 05.01.2004

<sup>31</sup> Offshore Centre Denmark, Newsletter On/OFF 3, August 2004, COWI A/S, page 7

<sup>32</sup> Per Hjelmsted Pedersen "Nysted Offshore – success down to hard work", Wind Kraft Journal, page 8 – 17, 4/2004

*Bonus A/S* designed and produced the wind turbines, blades and piles. *A2Sea* was responsible for the offshore installation of turbines, blades and piles.

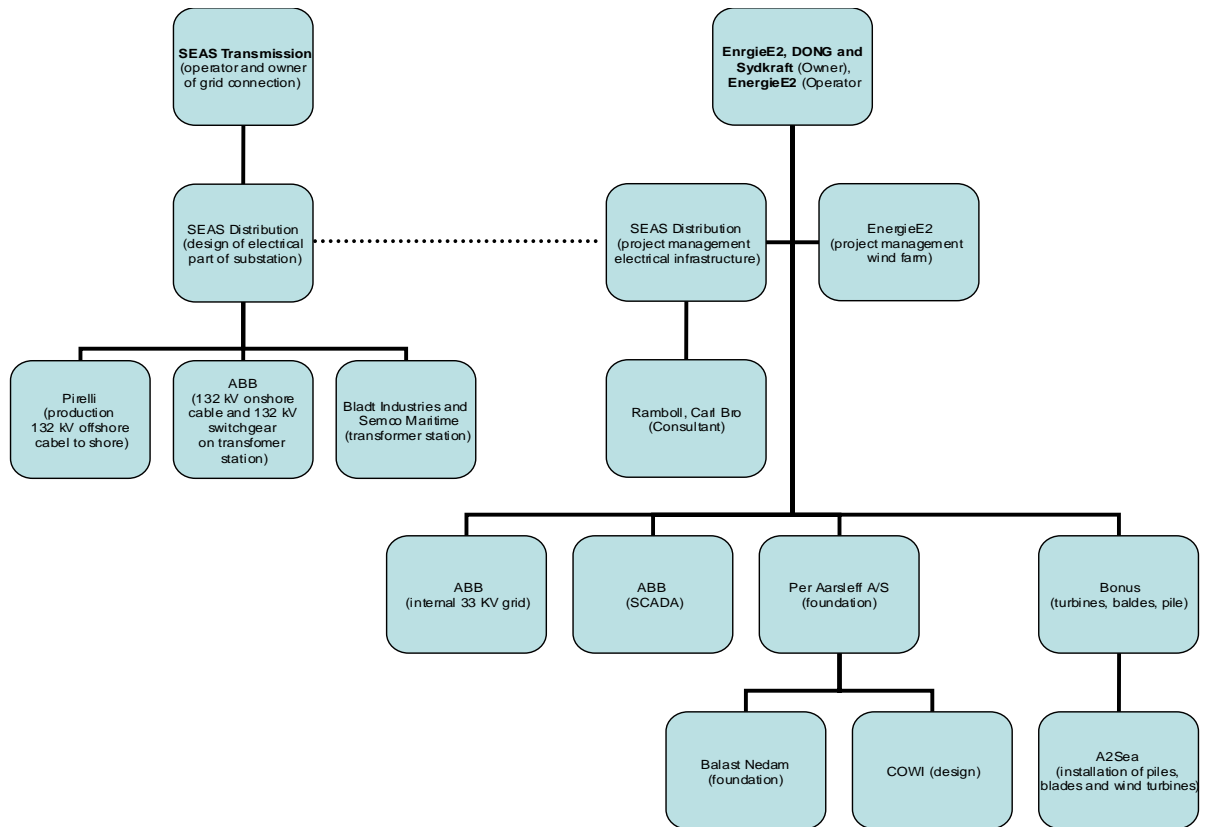

Figure 8-2: Project structure of Nysted Offshore Wind Farm.

### **Media strategy:**

*ENERGI E2* has published information on the project in local newspapers, opened a visitor centre and has a website with project-specific information ([www.nystedhavmoellepark.dk](http://www.nystedhavmoellepark.dk)) in Danish, English and German. Issues covered by the website include:

- Background: Why offshore wind turbines? Technical data about the farm, who built it, environmental impact assessment reports and about the Nysted area
- Environment: during construction, after construction and download of reports (on benthic, seals, porpoise, birds and underwater noise)
- Sailing directions, map
- Links
- Tour of the farm
- Press: photos (turbine, area, wind farm, visualisation), press releases, reports

Main messages in press releases:

- 30-07-2000 “Danish Energy Agency approves offshore wind farm at Rødsand.” New offshore wind farm will cut Danish emissions of CO<sub>2</sub>, SO<sub>2</sub> and NO<sub>x</sub>.
- 04-09-2001, “Ownership behind Nysted Offshore Wind Farm in place.” *ENERGI E2 A/S*, *DONG A/S* and the Swedish energy company *Sydkraft* signed a joint venture agreement on the coming Nysted Offshore Wind Farm at Rødsand south of Lolland.

- 08-10-2001, “Supplier selected for Nysted Offshore Wind Farm.” As operator of the consortium erecting Nysted Offshore Wind Farm near Rødsand, ENERGI E2 has signed a contract with the wind turbine manufacturer Bonus Energy A/S. The contract covers 72 wind turbines.
- 19-03-2002, “Contractor chosen for 73 Concrete Foundations at Nysted Offshore Wind Farm at Rødsand.” ENERGI E2 has signed a contract with the contracting company Per Aarsleff A/S. The contract comprises 73 concrete foundations: 72 wind turbine foundations and one foundation for a transformer substation
- 29-07-2003, “Last offshore wind turbine erected at Nysted.” This means that all 72 turbines have now been placed on their foundations and ten of them are already producing electricity.
- 09-01-2004, “Nysted Offshore Wind Farm handed over one month ahead of schedule.” On 1 December the suppliers officially handed over one of the world’s largest offshore wind farms to its owners. The commercial commissioning took place one month ahead of the originally scheduled date – an accomplishment not seen every day in connection with projects of this size.

The project team had an open-minded media strategy. SEAS and ENERGI E2 got an early start to obtain permission to cross the coast, which was expected to be time-consuming due to nature protection issues: birds, nature and landscape. Instead of presenting a finished project, SEAS and ENERGI E2 established a co-operation with all involved stakeholders as early as possible.<sup>33</sup>

### ***Planning (legislative):***

In June 1999, *SEAS Distribution* was granted permission to commence preliminary studies (EIAs) for the offshore wind farm.<sup>34</sup>

In 2001 the Danish Energy Authority approved the power company ENERGI E2’s application to establish an offshore wind farm at Rødsand.

The Danish authorities approved Nysted under the obligation that environmental studies are to be carried out in the period 2000-2006.<sup>35</sup>

Further details of the Danish planning regime for offshore wind turbines, the approval procedure and stakeholder involvement are laid down in a publication of the POWER project.<sup>36</sup>

### ***Environmental monitoring:***

The environmental monitoring started with the Environmental Impact Assessment (EIA) in 1999. Two years of baseline studies (before construction of the wind farm) and two years of monitoring during the operation phase followed. The programmes will continue until the end of 2006 (details see Figure 8-3) .

---

<sup>33</sup> Private Communication with Steen Beck Nielsen, SEAS-NVE Energy group, project manager for grid connection of Rødsand, October 2005, Copenhagen

<sup>34</sup> POWER Project “Offshore Wind Energy in the North Sea Region” POWER (Pushing Offshore Wind Energy Regions), Report, September 2005

<sup>35</sup> Andersen, Boesen “Environmental issues concerning offshore windfarms”, 2004

<sup>36</sup> POWER Project “Offshore Wind Energy in the North Sea Region” POWER (Pushing Offshore Wind Energy Regions), Report, September 2005

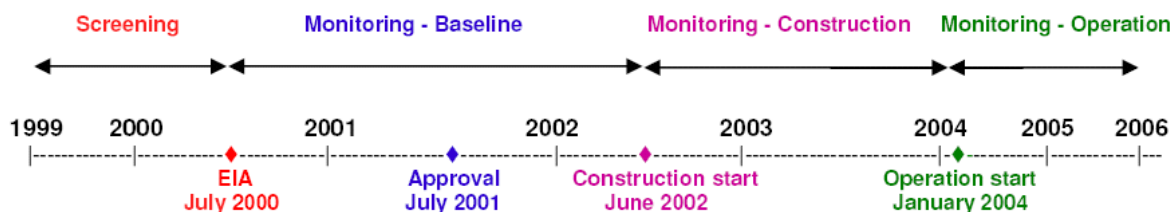

Figure 8-3: Time schedule for environmental investigations at Nysted Offshore Wind Farm <sup>37</sup>.

An international panel of independent experts, IAPEME (International Advisory Panel of Experts on Marine Ecology), is assessing the work of the environmental group. The experts evaluate the progress of the environmental monitoring programmes and make recommendations for future monitoring. On the basis of the recommendations of the expert panel, the environmental group sets priorities for future programmes.<sup>38</sup>

A “Green Group” is involved in the environmental monitoring debate. Representatives from WWF, the Danish Society for Conservation of Nature, the Danish Outdoor Council, Greenpeace, the Danish Ornithological Society and the Danish Organisation for Renewable Energy are participating.<sup>39</sup>

Through the studies, following the “Before / After Control Impact” approach, various effects of the wind farm have been investigated (details see Table 8-3). These include:

- Noise from constructing the wind farm
- Noise from operation of the wind farm (under and above water)
- Effects on migratory birds
- Underwater vibrations from operation of the wind farm
- Electromagnetic field near the underwater cables

Results are available from the environmental impact studies during and after construction (see website [www.nystedhavmoellepark.dk](http://www.nystedhavmoellepark.dk))

<sup>37</sup> Andersen, Boesen “Environmental issues concerning offshore windfarms”, 2004

<sup>38</sup> *ibid*

<sup>39</sup> *ibid*

Table 8-3: Programme and duration of environmental studies at Nysted Offshore Wind Farm<sup>40</sup>.

Programme	Year of monitoring
Visualisation and socio-economic investigation	1999, 2000, 2003, 2004
Hydrography and coastal morphology	1999, 2000, 2001, 2002, 2003
Benthic fauna and flora along 132 kV cable	1999, 2000, 2001, 2002, 2003, 2004
Benthic fauna and flora in the farm area	1999, 2001, 2005
Fish in the farm area	1999, 2001
Electromagnetic fields and possible effect on fish	2001, 2002, 2003, 2004, 2005
Monitoring of harbour porpoises	2001, 2002, 2003, 2004, 2005
Monitoring of seals	1999, 2002, 2003, 2004, 2005
Monitoring of birds	1999, 2000, 2001, 2002, 2003, 2004, 2005
Development of new habitats	2003, 2004, 2005

### ***Meteorological and Oceanographical investigation:***

Meteorological and oceanographical field measurement at Nysted began in 1997 at the site of the planned offshore wind farm location. It provided data for the planning process.

Two measuring poles have been erected offshore, near Gedser Rev, Denmark:

- The pole at Nysted has been equipped with 3 cup anemometers, 1 vane and 1 sonic anemometer, along with several thermometers.
- The pole near Gedser Rev has been equipped with 3 cup anemometers, one vane and 3 thermometers.<sup>41</sup>

### **8.2.2 Economics**

The costs of grid connection are split between the grid operator and the wind turbine owner: costs for the offshore grid junction point (transformer station, cable to shore, reinforcement of onshore cable) are paid by the grid operator, while the internal grid of the wind farm is paid by the owner of the turbines.<sup>42</sup>

The substation at sea and the offshore and onshore cable to Radsted had a value of 12% of the total cost of offshore Nysted wind farm. 72 turbines had a value of € 120 mil. The investment cost for the wind farm was € 1.51 mil. per MW (details see Table 8-4).

In 1999 the Danish Parliament decided to convert the state subsidy schemes for renewable electricity production to a market-based system for tradable green certificates with an obligation starting in 2001.<sup>43</sup>

The transmission system operator is responsible for the sale of the electricity production on the spot market for wind turbines connected to the grid prior to 2003. For turbines connected to the grid in

<sup>40</sup> ibid

<sup>41</sup> Winddata.com “database on wind characteristics - site Roedsand”, [www.winddata.com](http://www.winddata.com), October 2005

<sup>42</sup> POWER Project “Offshore Wind Energy in the North Sea Region” POWER (Pushing Offshore Wind Energy Regions), Report, September 2005

<sup>43</sup> ibid

2003 and later, the plant owner is responsible for the sale. Several fixed premiums and tariffs apply, depending on when a specific farm was brought into use.<sup>44</sup>

Table 8-4: Economics of Nysted Offshore Wind Farm<sup>45</sup>.

	Value Mil. €	Percentage %
Turbines	120	48
Foundations	45	18
Internal Grid	15	6
SCADA	10	4
Substation, offshore and onshore cable to Radsted	30	12
Others	30	12
Total	250	100
Investment cost per MW installed	1.51	

### 8.2.3 Technology

ENERGI E2 prepared a technically highly-detailed invitation to tender. The documents were developed evaluating ENERGI E2's experience gained in the construction, engineering and operation of conventional power stations and the power supply grid in eastern Denmark, as well as experiences from the offshore wind farms Vindeby (11 x 450 kW Bonus) and Middelgrunden (10 of the 20 x 2 MW Bonus wind turbines).

#### *Selection of the turbines:*

Specific requirements in the tender documents covered availability, reliability and ease of servicing. The following parameters were important for the selection of the turbines:<sup>46</sup>

- 96% guaranteed availability
- Lightning protection<sup>47</sup>
- Low air humidity in the tower for corrosion protection
- Mounting of large components with an integral crane
- Ability to open nacelle completely
- Lift for service staff and servicing materials
- Fire protection throughout the electrical system with arc detection
- Demonstration of ease of servicing with a fully equipped full-size model of the lower tower section (tests to replace equipment),

<sup>44</sup> *ibid*

<sup>45</sup> Per Hjelmsted Pedersen "Nysted Offshore -- success down to hard work", *Windkraft Journal*, 4/2004

<sup>46</sup> Per Hjelmsted Pedersen "Nysted Offshore -- success down to hard work", *Wind Kraft Journal*, page 8 – 17, 4/2004

<sup>47</sup> Great emphasis was put on this because lightning strikes are more frequent at sea than on land. Details are laid down in the Danish Recommendation for Lightning Protection.

- Erection of a prototype turbine at Rødby Haven (onshore), an exact model of the 72 turbines at Nysted
- Practical tests (e.g. installation and removal of major components) and training programmes at the prototype turbine

The turbines are produced by Danish manufacturer Bonus (now Siemens). The turbines are dimensioned to 2.3 MW and were the largest available from Bonus at the time (2004). These turbines are an upgrade of Bonus 2 MW turbines.

Start wind: 3 m/s

Stop wind: 25 m/s

Rated power: 2.3 MW at 15 m/s

### ***Selection of blades:***

Bonus A/S developed a special blade technology for the 2.3 MW turbines at offshore Nysted wind farm. Blades are produced in one piece with no glue joints.

The first set of blades was pre-tested on a 1.3 MW turbine in the year 2000. It was removed one year later for full inspection.

Bonus A/S built a facility to test prototypes and blades picked at random from serial production. Tests comprised dynamic testing corresponding to a 20-year lifetime and pulling blade to fracture.<sup>48</sup>

### ***Selection of the foundation:***

The offshore windmill foundation design had to consider operational and environmental loads as well as hydrographical and geotechnical conditions at the site of the Nysted wind farm. The suitability of the foundation type was determined by technical factors, including:

- turbine size
- soil conditions
- water depth
- wave heights
- formation of ice

The hydraulic model studies included probabilistic definition of extreme events, numerical modelling of wave disturbance, and calculation of wave, current and ice forces. Loads from current and waves in the form of time series were combined with the wind load of the turbine.<sup>49</sup>

Hydraulic model studies were performed for the scour protection and operational aspects for the crane barge to place the foundations.<sup>50</sup>

The foundations take up an area of about 45,000 m<sup>2</sup>, corresponding to 0.2% of the total area of the wind farm.<sup>51</sup>

---

<sup>48</sup> Henrik Stiesdal "Nysted Offshore – Success down to hard work" BONUS Energy A/S, Wind Kraft Journal 5/2004, page 50- 55

<sup>49</sup> Joergen Lisby, Jesper Jacobsen "Installation – Concepts and Risks", Per Aasrsleff A/S, Copenhagen Offshore Wind 2005

<sup>50</sup> ibid

<sup>51</sup> Andersen, Boesen "Environmental issues concerning offshore windfarms", 2004

Monopile foundations were not feasible at Nysted due to high concentration of boulders. The soil conditions (stiff moraine clay) were favourable for gravity foundations (see Figure 8-4), because generally high-bearing capacity was met near the natural seabed.<sup>52</sup> Foundation levels vary from -7.5 metres to -12.5 metres. The foundation level was raised by construction a thick, compacted stone bed.<sup>53</sup>



Source: Aarsleff<sup>54</sup>



Source: dena

Figure 8-4: Gravity foundation for Nysted Offshore Wind Farm.

The transport and installation procedures required that the weight of the concrete foundation units be minimised. This was achieved by designing a hexagonal base structure with six open cells and a shaft and ice cone at the top. The base dimension is 15 m and the maximum height 16.25 m. By these means, a concrete weight (in air) of under 1,300 t was achieved, allowing marine operations. The crane barge EIDE V lifted the foundation from the transport barge.

The necessary weight to provide stability against sliding and overturning was then provided by heavy material filled in the cells and the shaft, adding another 500 t to the weight.<sup>55</sup>

Scour protection was a two-layer system with armour stones and a filter layer. The material was placed by a hydraulic excavator from a barge.<sup>56</sup>

<sup>52</sup> Offshore Centre Denmark, Newsletter On/OFF 3, August 2004, page 7

<sup>53</sup> Joergen Lisby, Jesper Jacobsen "Installation – Concepts and Risks", Per Aarsleff A/S, Copenhagen Offshore Wind 2005; The publication proposes detailed requirements for data needed for tender documents and the design of foundations.

<sup>54</sup> Aarsleff "Offshore wind farm at Rødsand", Abyhøj, 05.01.2004

<sup>55</sup> Offshore Centre Denmark, Newsletter On/OFF 3, August 2004, COWI A/S, page 7

<sup>56</sup> Joergen Lisby, Jesper Jacobsen "Installation – Concepts and Risks", Per Aarsleff A/S, Copenhagen Offshore Wind 2005

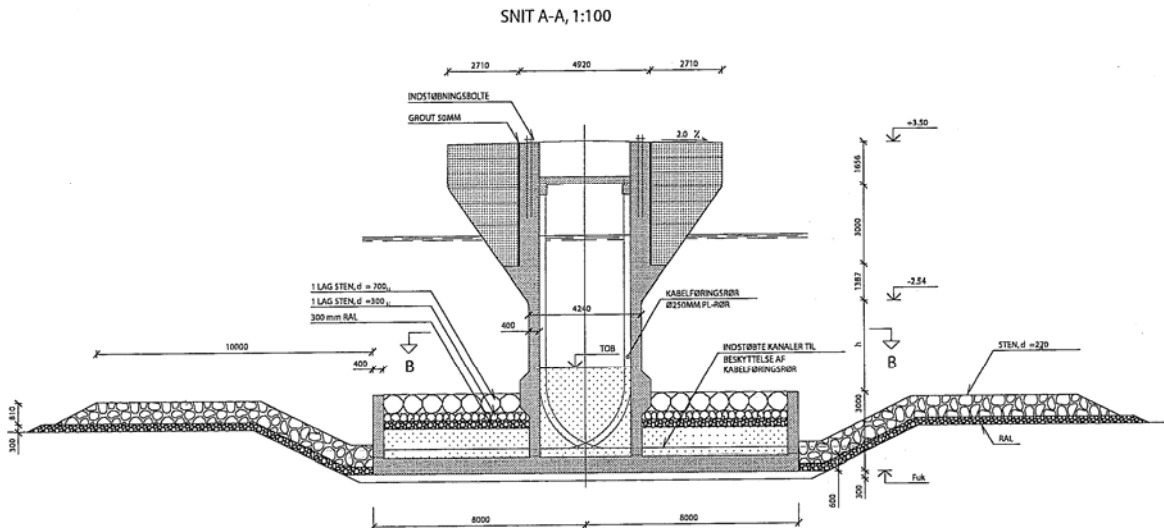

Figure 8-5: Foundation and scour protection for Nysted Offshore Wind Farm (Source: Aarsleff<sup>57</sup>).

### **Tower:**

Each tower is 69 m high. This is about 10% shorter than towers of onshore turbines, due to the fact that wind shear is higher onshore than offshore - thus shorter towers are needed to obtain the same amount of power<sup>58</sup>.

### **Grid connection :**

To integrate the 165 MW Nysted Offshore Wind Farm into the power supply system, an analysis of the regional network was made, taking into account the existing 250 MW of onshore wind farms in Falster and Lolland. Compared to the maximum load of 150 MW, the wind energy exceeds the maximum load of Falster and Lolland.<sup>59</sup> Elcraft made calculations for the whole grid system (safety and load flow). The analysis came to the conclusion that it was necessary to reinforce the existing network (see Figure 8-6).

SEAS Distribution prepared, managed and implemented all grid reinforcement activities. In detail, the technical and economic analyses of network design covered:<sup>60</sup>

- A choice between AC or HVDC technology in relation to the grid connection of the wind farm
- Transient net stability: the need for dynamic reactive compensation
- Static network conditions: reinforcement of 132 kV sea crossings at Lolland and Falster.

The conclusions:<sup>61</sup>

- The wind turbines in the offshore wind farm would be connected with an 33 kV cable network (length of 48 km).
- Conventional AC technology would be the most cost-effective solution to connect the wind farm with the onshore network, including a 33/132 kV offshore transformer station, 11 km of 132 kV sea-to-land cable and 18 km of 132 kV land cable to Radsted.

<sup>57</sup> Aarsleff "Offshore wind farm at Rødsand", Abyhøj, 05.01.2004

<sup>58</sup> Morton Madsen, Roedsand Offshore Wind Farm, Esbjerg 2004

<sup>59</sup> Private Communication with Steen Beck Nielsen, Copenhagen, October 2005

<sup>60</sup> *ibid*

- The onshore network would need additional dynamic reactive compensation. The existing Radsted 132 kV substation had to be extended, including a 40 MVar reactor and bus-bar protection. A dynamic phase compensator with 65 MVar inductive and 80.2 MVar capacitive would have to be established at Radsted.
- The existing 132 kV onshore network would need reinforcement: 2 km of 132 kV sub-marine cable at *Guldborg Sund* and 8 km of 132 kV sub-marine cable at *Storstrømmen Sound*.

The reinforcement of the grid took 4 years. It has been completed.

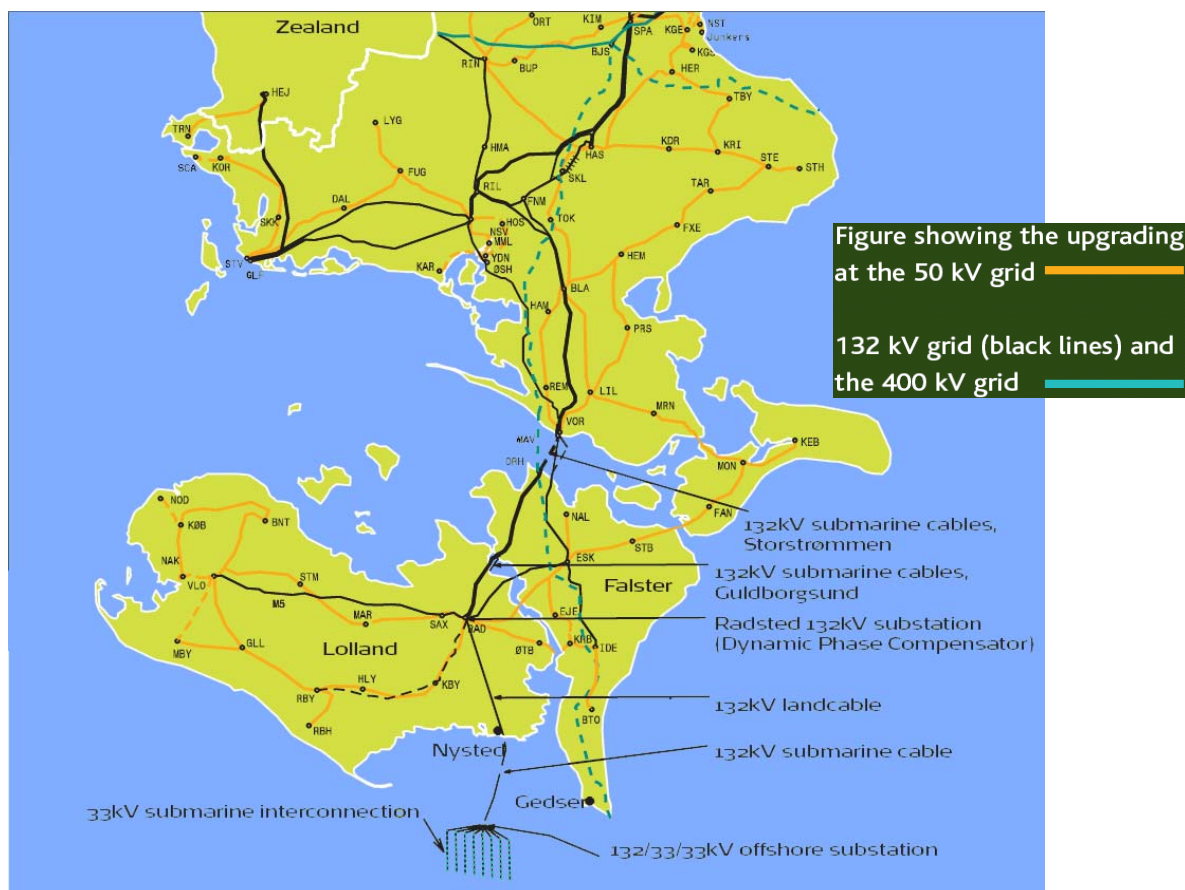

Figure 8-6: Grid connection of Nysted Offshore Wind Farm and reinforcement of transmission grid of Lolland / Falster / Zealand<sup>62</sup>.

The main obstacles to realising planning were:<sup>63</sup>

- Lack of experience: Nysted was the first offshore wind farm built by SEAS and ENERGI E2.
- Early decision was necessary as to whether a helicopter deck and sleeping accommodations on the transformer station were needed. This decision was important for the design and influenced the investment costs.
- Coast at Lolland has a high level of nature protection.

SEAS was successful in overcoming the obstacles, because all the engineering expertise required for the wind farm and the grid was available at SEAS office in Haslev. The team had 5 experts who worked 1.5 – 2 years to define the overall concept. SEAS followed the strategy of keeping everything as simple as possible while keeping operation costs as low as possible. This meant:<sup>64</sup>

<sup>61</sup> *ibid*

<sup>62</sup> SEAS-NVE Energy Group “Offshore Wind Farms”, Denmark, Brochure 2005

<sup>63</sup> Private Communication with Steen Beck Nielsen, Copenhagen, October 2005

<sup>64</sup> *ibid*

- All cables in the wind farm were in line (no star configuration).
- No by-pass was built, as it would be only cost-effective if more than 3 failures (2 weeks without production) occurred in the lifetime of the wind farm. This was not expected.
- The cable to shore has no (n-1) security, because the risk of anchor damage is very low. The cable does not cross any shipping lanes and there is a RAMSA area nearby. There is no ground fishery because of the surrounding large stones.

#### ***Helicopter deck:***

Because of very favourable weather data, SEAS decided not to have a helicopter deck or sleeping facilities. The transformer station can be reached and exited by boat 80% of the year – which was regarded as often enough. This decision was one of the project milestones and significantly reduced its costs: Compared to the Horns Rev offshore wind farm in the North Sea, investment costs of the Nysted transformer station were only 50%.<sup>65</sup>

### **8.3 Installation and operation phase**

#### ***Concrete foundations:***

The concrete foundations were fabricated in Swinoujscie, Poland and transported on barges to the site, where a crane picked the units up and placed them onto pre-fabricated stone beddings.<sup>66</sup>

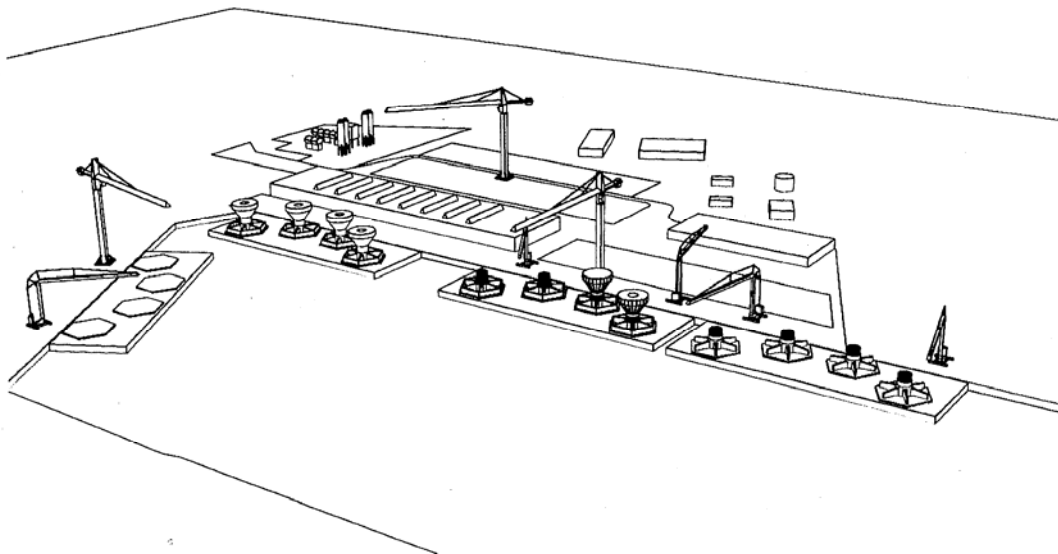

Figure 8-7: Production site for gravity foundations in Odraport Swinoujscie, Poland (Source: Aarsleff<sup>67</sup>).

The production cycle for 4 foundations on one 10,000 t barge (92 x 28 x 6.5 metres) was carried through in 30 days or less. With 3 barges in the line, 4 foundations were placed every 10 days, weather permitting (see Figure 8-7).

<sup>65</sup> ibid

<sup>66</sup> Offshore Centre Denmark, Newsletter On/OFF 3, August 2004, COWI A/S, page 7

<sup>67</sup> Aarsleff "Offshore wind farm at Rødsand", Abyhøj, 05.01.2004

**Foundation:**

Four gravity foundations were transported by barge from Poland to the wind farm. On arrival to the site, the barge was connected to a pre-placed anchor.

Installation of wind turbines, piles and blades:

A2SEA transported and installed 72 BONUS 2.3 MW offshore turbines. The project was completed within 80 days from first turbine installation to final lift of the last turbine component.

- Vessels: by A2SEA, MS Ocean Ady
- Installation period: 80 days from May to July 2003
- Distance from harbour: Logistic centre at Nyborg was 85 miles from Nysted
- Lifting operations: 4 lifts per turbine, 4 turbines per sequence
- Turbine specifications, hub height: 68.8 metres above sea level

A special rack for stacking four rotors on top of each other (see Figure 8-8) was fitted on deck of the installation vessel. To ensure safe working conditions during both loading and installation, a complete mock-up of the rotor rack was fabricated and tested before installation work started.

Turbine erection was done by four crane operations (tower bottom section, tower top section, nacelle and rotor). Service staff fastened the necessary bolts immediately after each of the four components were placed. The vessel then sailed to the next foundation.

The required installation time amounted to less than 1 day per turbine. A round-trip of the installation vessel took 72 hours under optimal conditions – which meant one turbine was installed in 18 hours. The work was completed one month ahead of schedule.<sup>68</sup>

A2Sea put great emphasis on the seabed conditions for jacking the vessel. A sonar array was installed to detect debris and other obstacles on the seabed. The aim was to avoid losing base plates, as happened in other projects.

---

<sup>68</sup> Poul Skjoerboek, “A logistic challenge” Bonus energy A/S, ON/OFF-Newsletter, Offshore Centre Denmark, August 2004, page 3



Installation vessel;  
source: A2Sea Management Report 2003



Rack for stacking four rotors;  
source: Siemens Wind Power<sup>69</sup>



Installation vessel A2Sea;  
Source: Siemens Wind Power<sup>70</sup>



Special rack for stacking four rotors on top of each other; Source: Offshore Centre Denmark<sup>71</sup>

Figure 8-8: Installation of wind turbines, piles and blades at Nysted Offshore Wind Farm with MS Ocean Ady.

### 8.3.1 Installation and grid connection

#### ***Seabed preparation:***

A small hopper vessel equipped with a hydraulic excavator was used for the main dredging work. The mean dredging below sea bottom was around 2 metres.<sup>72</sup> Dredging tolerance was held within a limit of

<sup>69</sup> Steffen Frydendal Poulsen, Poul S. Skjaebaek "Efficient Installation of offshore wind turbines – lessons learned from Nysted Offshore wind farm", Siemens Wind Power, Brande, 2005

<sup>70</sup> ibid

<sup>71</sup> Poul Skjoerboek, "A logistic challenge" Bonus energy A/S, ON/OFF-Newsletter, Offshore Centre Denmark, August 2004, page 3

<sup>72</sup> Joergen Lisby, Jesper Jacobsen "Installation – Concepts and Risks", Per Aasrsleff A/S, Copenhagen Offshore Wind 2005

+/- 0.30m. The dredging material was dumped at a nearby site at sea. A steel frame was placed and levelled. It was installed to guide for the stone bed.<sup>73</sup>

#### Lifting operation for placing the foundations:

The lifting operation for placing the foundations was carried out with the crane barge EIDE V. The EIDE V is equipped with a four-anchor system and a spud leg to secure the correct holding in place during the placement operation. The barge is self-propelled, and has a supporting tug for anchor handling and assistance for the positioning operation. The placing sequence is as follows:<sup>74</sup>

- EIDE V placed itself on the side of the transport barge in front of the foundation. It was moored to the barge.
- The sea fastenings on the foundation were removed. At the same time, the lifting frame was positioned around the ice cone.
- The foundation was lifted from its place on the transport barge. The barge was continually ballasted to keep its trim.
- EIDE V left for the position of the foundation. On arrival it was linked to pre-positioned anchors. Using the anchors and the spud, the exact position was secured.
- The foundation was lowered into place onto the prepared stone bed. During the lowering operation, the position was monitored constantly. If required, it was corrected by use of the anchors.
- After touch-down and subsequent transfer of the foundation's weight onto the stone bed, the position and level of the foundation were controlled. The lifting frame was disengaged hydraulically and EIDE V left the position for its next operation.
- The flexible part of the cable pipes was extended from the foundation onto the seabed, ready to receive the cables.

Major influences on the success of the operation were:

- Safe anchoring of transport barges
- Safe sea fastening of foundation
- Short installation time to fit within weather windows
- Suitable equipment
- Management of risks caused by waves, tides and current

#### ***Wind turbines:***

*Bonus A/S* focussed on supply chain management intensively from an early stage – from the manufacturing and assembly of main components at company facilities to commissioning at the wind farm site. The main time-consuming tasks were highlighted and optimised. The critical component was sea transport from Nyborg to the site and back. The loading process of the vessel was an important issue during optimisation. The following factors were optimised for the project:<sup>75</sup>

- Design review
- Tower mock-up
- Preparation of installation vessel

<sup>73</sup> Aarsleff "Offshore wind farm at Rødsand", Abyhøj, 05.01.2004

<sup>74</sup> Joergen Lisby, Jesper Jacobsen "Installation – Concepts and Risks", Per Aarsleff A/S, Copenhagen Offshore Wind 2005

<sup>75</sup> Steffen Frydendal Poulsen, Poul S. Skjaebaek "Efficient Installation of offshore wind turbines – lessons learned from Nysted Offshore wind farm", Siemens Wind Power, Brande, 2005

- Preparation base harbour
- Nacelle assembly
- Hub assembly
- Blade manufacturing
- Onshore transportation
- Rotor assembling
- Tower assembling
- Vessel loading
- Wind turbine erection
- Commissioning

Bonus A/S choose the port of Nyborg to ship components to the wind farm site, although it was 80 nautical miles away from Nysted, because of:<sup>76</sup>

- Very good accessibility by both sea and road (supply of turbines, blades and piles required more than 700 truck loads)
- More than 60,000 m<sup>2</sup> of storage and assembly area right at the quayside
- A need to ensure optimum flow of goods throughout the vessel loading process
- Lack of heavy ferry traffic, which would put severe restrictions on installation efficiency
- Ability to start vessel loading immediately upon arrival

---

<sup>76</sup> Poul Skjoerboek, "A logistic challenge" Bonus energy A/S, ON/OFF-Newsletter, Offshore Centre Denmark, August 2004, page 3



Area for pre assembly; Source: dena



Rotor assembly;  
Source Siemens wind power<sup>77</sup>



Material at quayside;  
Source: Offshore Centre Denmark<sup>78</sup>



Material at quayside;  
Source: dena

Figure 8-9: Logistic Centre in Port of Nyborg (Denmark)

### ***Installation of transformer station:***

In 2002 Semco Maritime entered into a contract with Bladt Industries A/S to build a transformer platform for the Nysted offshore wind farm. The transformer is a four-level, partly enclosed steel structure with decks (total weight 670 tonnes). The structure dimensions are 16 x 13 x 23 (h x w x l) m.<sup>79</sup> Electricity is transformed from 33 kV to 132 kV.

The platform is divided into a high-current area (transformer, distribution frame and main breakers) and an area for the remaining facilities. These facilities comprise emergency generator, batteries,

<sup>77</sup> Steffen Frydendal Poulsen, Poul S. Skjaebaek "Efficient Installation of offshore wind turbines – lessons learned from Nysted Offshore wind farm", Siemens Wind Power, Brande, 2005

<sup>78</sup> Poul Skjoerboek, "A logistic challenge" Bonus energy A/S, ON/OFF-Newsletter, Offshore Centre Denmark, August 2004, page 3

<sup>79</sup> CWO Semco Maritime "Rødsand Transformer Platform, [www.offshore-technology.com](http://www.offshore-technology.com), 2002

storage etc., and turbine control panels.<sup>80</sup> Cables from the eight rows of wind turbines are lead into the transformer station by sea cable.<sup>81</sup>



Figure 8-10: Construction and installation of the Nysted wind farm transformer station (Source: Bladt Industries A/S).

### 8.3.2 Operation

ENERGI E2 signed a five-year service contract with Bonus as part of the turbine contract. The small ferry harbour at Gedser is used as base for the service works. A small crew of ENERGI E2 staff will gradually replace Bonus staff to enable a smooth out-phasing after five years. Boat landing is possible at wave heights up to 1.2 m: 155 days in summer and 130 days in winter.

Bonus A/S estimates 2 visits per turbine per year for the first ten years. Visits are projected to rise later, due to more expected problems by the end of the turbine lifetime (see Figure 8-11).

Average turbine availability was 91.5% for the commissioning period of July-November 2003.<sup>82</sup>

Average turbine availability rose to 97% for the period December 2003 to March 2005. Average farm availability (average percentage of available wind farm power) is 96% for the period after commissioning.<sup>83</sup> The grid-caused availability loss after commissioning is around 1%.<sup>84</sup>

<sup>80</sup> *ibid*

<sup>81</sup> *ibid*

<sup>82</sup> P.Volund, P.H. Pedersen, P.E. Ter-Borch "165 Nysted Offshore wind Farm. first year of operation - performance as planned" Copenhagen, 2005

<sup>83</sup> Per Hjelmsted "Energi E2 as an operator of offshore wind farms: the Nysted project, technology considerations, international consent procedures" Conference *Windforce05 Course offshore*, Bremerhaven, 26-27 May 2005

<sup>84</sup> P.Volund, P.H. Pedersen, P.E. Ter-Borch "165 Nysted Offshore wind Farm. first year of operation - performance as planned" Copenhagen, 2005

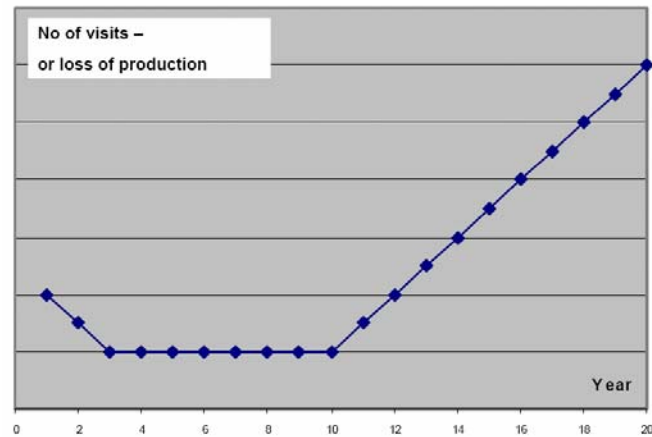

Figure 8-11: Expected number of visits at Nysted offshore wind farm during wind farm lifetime<sup>85</sup>.

Continuous 24-hour remote supervision of the wind turbines has been realised. Two vessels are on the job 14 hours a day (only one vessel is used in winter). In case of bigger problems, a jack-up barge and crane vessels can be called upon at short notice.<sup>86</sup>

Loads up to 3 tonnes are lifted from a small floating vessel onto the wind turbine platform. Boat-landing is facilitated by 360 degree landing access and the low height of the platforms above sea level.

The following defects were handled after commissioning:<sup>87</sup>

- Exchange of two gear-box bearings
- Lightning strikes
- Improved air conditioning of transformer
- Improved cooling in main transformer
- Improving aircraft warning lights synchronisation (via satellite)



Figure 8-12: Small boat access for operation and maintenance services at Nysted (Source: ENERGI E2<sup>88</sup>).

<sup>85</sup> Per Hjelmsted "Energi E2 as an operator of offshore wind farms: the Nysted project, technology considerations, international consent procedures" Conference *Windforce05 Course offshore*, Bremerhaven, 26-27 May 2005

<sup>86</sup> *ibid*

<sup>87</sup> *ibid*

<sup>88</sup> P.Volund, P.H. Pedersen, P.E. Ter-Borch "165 Nysted Offshore wind Farm. first year of operation - performance as planned" Copenhagen, 2005

## 8.4 Lessons learnt

The Nysted Offshore Wind Farm project had strong political support from the Danish Government. The objective of the wind farm was to investigate the economic, technical and environmental aspects of offshore development in Denmark.

The wind farm is owned by a joint venture of ENERGI E2, DONG and Swedish Sydkraft. SEAS Transmission A/S is the owner of the grid connection (the substation at sea and the cabling from the substation and onshore cable to national grid). The wind farm went on-line on 1 December 2003.

The owner followed a multi-contracting approach. Several lessons were learnt from this: enough staff with sufficient knowledge had to work in detail on the planning of all main elements of the project, including the reinforcement of the onshore transmission grid. Preparation of the tender documents was an important step. The technically highly-detailed invitation to tender had to be prepared. Documents were developed which evaluated experiences gained during the construction, engineering and operation of conventional power stations and the power supply grid, as well as experiences from other existing offshore wind farms. Coordination was supported by the fact that all engineering expertise for the wind farm and the grid was available at one office.

A fundamental requirement for the success of the project was that the developer had full access to the contractors' design process and quality control (factory acceptance tests). The developer realised a very good working relationship with the manufacturer from design to pre-installation and from erection to commissioning. While maintaining the full responsibility for design, the manufacturers/contractors discussed details of the concept with the developer.

An early decision was necessary as to whether a helicopter deck and sleeping facilities were needed on the transformer station. This decision was important for the design and influenced the investment costs. Because of very good weather, it was decided not to have a helicopter deck or no sleeping facilities on the transformer station. The transformer station can be reached and exited by boat 80% of the year – which was regarded as often enough.

The developer followed the strategy of keeping everything as simple as possible while keeping operation costs as low as possible. This meant all cables in the wind farm were in line (no star configuration), no by-pass was built, and the cable to shore has no (n-1)-security.

The turbine manufacturer focussed on supply chain management intensively from an early stage – from the manufacturing and assembly of main components at company facilities to commissioning at the wind farm site. The critical component was the sea transport from the logistic centre (Nyborg, 85 miles from Nysted) to the site and back. The loading process of the vessel was an important issue during optimisation.

The choice of logistics port focussed on very good accessibility by both sea and road (supply of turbines, blades and piles required more than 700 truck loads), sufficient storage and assembly area at quayside (60,000 m<sup>2</sup>), no heavy ferry traffic (which would put severe restrictions on installation efficiency) and the ability to start vessel loading immediately upon arrival. The installation time amounted to less than 1 day per turbine. The work was completed one month ahead of schedule.

The turbine manufacturer pre-tested the first set of blades on a 1.3 MW turbine in the year 2000. They were removed one year later for full inspection. A facility was built to test prototypes and blades picked at random from serial production. The tests comprised dynamic testing corresponding to a 20-year lifetime and pulling blade to fracture.

To ensure ease of servicing, a fully equipped, full-size model of the lower tower section was built onshore before serial production started. Replacement of the main equipment was tested. In addition, a prototype turbine was built as an exact model of the 72 turbines at Nysted. Practical tests such as

installation and removal of major components and training programmes using prototype turbines were realised.

The project is accompanied by a sophisticated environmental monitoring program. An International Advisory Panel of Experts on Marine Ecology and a “Green Group” were involved in details about the environmental monitoring. Basic studies, following the “Before / After Control Impact” approach, analysed various possible effects of the wind farm, including noise from constructing the wind farm, noise from operation of the wind farm (under and above water), effects on migratory birds, underwater vibrations from operation of the wind farm, fish and benthic surveys as well as electromagnetic field near the underwater cables. Two years of baseline studies (before construction of the wind farm) and two years of monitoring during operation phase followed. The programmes will continue until the end of 2006. Reports are published on the website (<http://uk.nystedhavmoellepark.dk/frames.asp>).

## 9 Scroby Sands (United Kingdom)

### 9.1 General

#### 9.1.1 Project description

Scroby Sands is one of the first offshore wind farms in the United Kingdom (UK). It has been online since 2004. E.ON UK Renewables Offshore Wind Ltd (EROWL) is the owner of the wind farm.

The wind farm is located 2.5 km offshore Great Yarmouth on the east coast of Anglia. The wind farm comprises 30 turbines with an installed capacity of 60 megawatts. The water depth is 5 – 10 m. The cables were brought ashore in Great Yarmouth, North Denes and connected to the local grid network system in Great Yarmouth, Admiralty Road substation.

Table 9-1: General description of Scroby Sands Offshore Wind Farm.

Project description	
Project name	Scroby Sands
Country/region	United Kingdom, Great Yarmouth, Norfolk
Name of owner	E.ON UK Renewables Offshore Wind Ltd (EROWL)
Name of developer	E.ON UK Renewables Offshore Wind Ltd (EROWL)
Location	3 km off the east coast of Caister, Norfolk Cable landfall: Great Yarmouth, North Denes Grid connection: Great Yarmouth, Admiralty Road substation <sup>89</sup>
Area in km <sup>2</sup>	10
Water depth	3 – 12 m <sup>90</sup>
Distance to shore	2,5 km
Operator's website	<a href="http://www.eon-uk.com">www.eon-uk.com</a>

<sup>89</sup> Hansen and Gislason

<sup>90</sup> Anne-Marie Coyle "Scroby Sands Offshore Wind Farm Update", 18 April 2002, Powergen

### 9.1.2 Technical data

Table 9-2: Technical data of Scroby Sands Offshore Wind Farm<sup>91</sup>.

Technical data	
Total installed capacity	60 MW
Energy generation per year	171 GWh <sup>92</sup>
Number of turbines	30
Name of turbine manufacturer and rating	Vestas V80 2 MW
Hub height	68 m above sea level
Rotor diameter	80 m
Piles:	
Diameter	4.2 m
Length	40 to 50 m
Weight	up to 200 tonnes
Buried depth	30 m
Height above MSL	8 m
Tower:	
Diameter	4.2 m
Length	60 m
Weight	110 tonnes
Turbine:	
Nacelle weight	65 tonnes
Blade weight	6.5 tonnes

### 9.1.3 Time frame

EROWL started the invitation to tender for the EPIC contract in June 2002. Contractors were given only six weeks to complete bids for the work. The companies Vestas, Mammoet Van Oord, Mayflower Energy/JB Hydrocarbons, A2Sea, SLP/Bouygues and Mowlem/HydroSoil submitted bids. After analysing the result, EROWL decided to postpone the start of the construction phase from 2003 to 2004 and solicited revised bids. In February 2003 Vestas Celtic won the EPIC contract for all the offshore facilities.

Installation started in Autumn 2003. Production of the first of turbine began on 20 July 2004. Bad weather in summer troubled the planned commissioning, which delayed completion of all turbines until the end of October 2004. High winds continued to slow work. All reliability testing was ultimately completed by the end of November. All the turbines were online together for the first time on 14 December 2004. Commercial completion was realised on 31 December 2004. The farm was formally opened in March 2005.

<sup>91</sup> [www.eon-uk.com](http://www.eon-uk.com) –Scroby Sands Offshore Wind Farm

<sup>92</sup> Adrian Chatterton, E.ON UK Renewables, private communication, Copenhagen, 27 October 2005

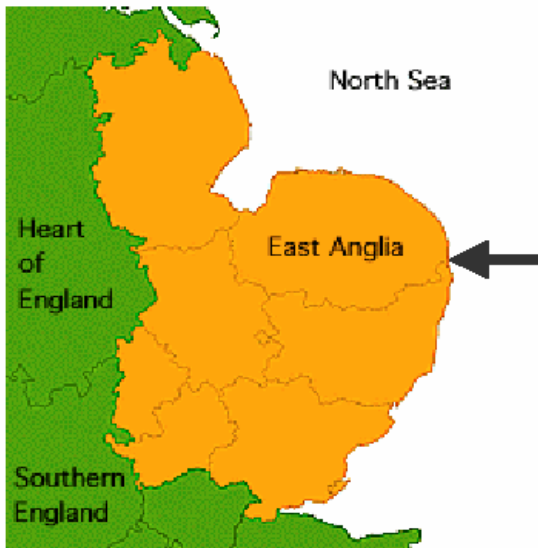

Location of Scroby Sands;  
Source: E.ON UK, Chatterton

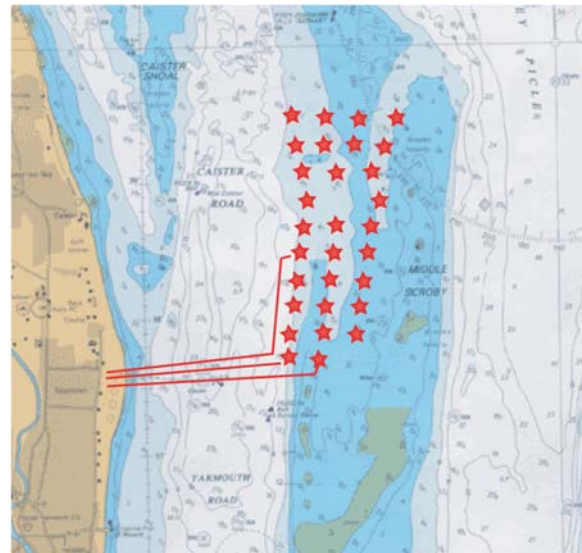

Location of Scroby Sands;  
Source: LI Offshore Foundation Series 0020



Scroby Sands; Source: Woodmann, ODE

Figure 9-1: Location of Scroby Sands offshore wind farm.

The time schedule for important work packages (planning, installation and commissioning) of the Scroby Sands offshore wind farm<sup>93, 94</sup>:

- Site assessment: 1993 - 1994
- Anemometry mast installed: 1995
- First and second invitation to tender and evaluation of bids: June 2002 / Feb 2003
- Project award: late Feb 2003
- Foundation installation: November 2003 / January 2004
- Onshore cable installation: April 2004 / April 2004

<sup>93</sup> Dan Woodmann, ODE, private communication, November 2005

<sup>94</sup> Douglas Westwood, "Scroby Sands- Supply Chain analysis"

- Turbine installation: April 2004 / May 2004
- Training of Vesta's staff: April 2004 / August 2004
- Inter-array cabling: May 2004 / August 2004
- Testing and commissioning: July 2004 / November 2004
- Project hand-off: August 2004 / December 2004

## 9.2 Project planning phase

### 9.2.1 Planning, approval and communication

The pre-project planning was realised by E.ON (formerly Powergen). General pre-project planning started in 1993.

E.ON UK Renewables Offshore Wind Ltd (EROWL) realised an EPIC contractor strategy. EROWL awarded the main contract to the turbine manufacturer Vestas Celtic. Vestas Celtic bore the majority of the risk of the project's construction phase and was contractor for all offshore procurement, installation and operations. Other work packages, such as grid connection, were tendered by EROWL.

EROWL commissioned Offshore Design Engineering Ltd (ODE) of Great Yarmouth to manage, monitor and co-ordinate the development of the Scroby Sands wind farm. The work scope of ODE covered the following aspects:<sup>95</sup>

- Internal controlling system and interface management
- Health, safety and environment (HSE) / quality assurance and control
- Design & manufacturing
- Construction & commissioning
- Onshore
- Offshore piling
- Pre-assembly & delivery of large items
- Offshore tower installation
- Offshore turbine installation
- Offshore cable installation
- Connection to public energy supply (PES)
- Commissioning

Internal communication was organised through ongoing interface and project management meetings covering all aspects and disciplines of the project.

#### **Contracts**

The following main contracts were concluded within the project's framework:<sup>96, 97</sup>

Offshore EPIC contract: Vestas Celtic Wind Technology Ltd was responsible for the supply and installation of piles, towers, nacelles, blades and infield cables, as well as marine operations and field

---

<sup>95</sup> [www.ode-ltd.co.uk](http://www.ode-ltd.co.uk)

<sup>96</sup> ibid

<sup>97</sup> Douglas Westwood, "Supply Chain Study- Scroby Sands", page 24

commissioning. The contract included operation and maintenance on the site for a period of five years. Vestas subcontracted:

- *Halliburton KBR* to manage the development project
- *Cambrian Engineering* to supply piles
- *Isleburn Mackay and Macleod* to supply piles
- *Mammoet Van Oord* to install foundations
- *AEI Cables* to deliver infield and export offshore cables
- *CNS Subsea* to install infield and export offshore cables
- *A2Sea* and *Seacore* to install piles, nacelles, blades (24 turbines, nacelles and blades by *A2Sea* in deep water and 6 by *Seacore* in shallow water locations)

Cable supply contract: *Pirelli Cables Ltd* supplied the onshore cables.

Onshore cable installation contract: *NACAP Infrastructure UK Ltd* installed all onshore cables.

Onshore cable connection contract: *EDF Energy Ltd* (formerly 24-7) modified the onshore substation (public electricity supply (PES) at Admiralty Road Substation) to accept the incoming cable. They realised the physical connection and tested cables that had been previously specified to the local grid network system.

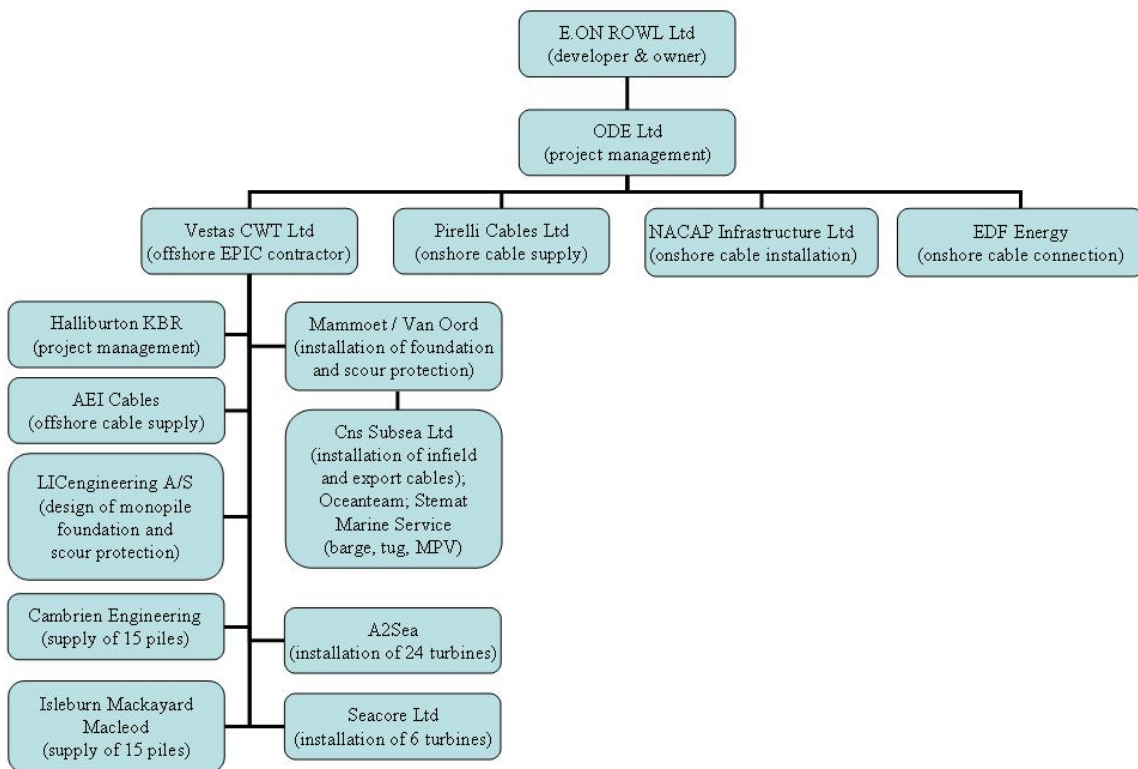

Figure 9-2: Companies involved in the Scroby Sands offshore wind farm (main contracts).

**Media strategy:**

Main elements of EROWL's media strategy involved press releases, press articles and interviews (journalists from national newspapers), radio interviews (BBC Radio 5 live) and television programmes (regional television and current affairs programmes), as well as general support of local interest groups.

EROWL was active in the "Caister Lifeboat" charity project. Acceptance at Great Yarmouth was gained through events such as Yarmouth in Bloom and electric blanket-testing.

A visitor centre (see Figure 9-3) was opened to inform tourists and local residents about the wind farm, energy efficiency and renewable energy in general.

E.ON UK has published some very general information about the project on its website [www.eon-uk.com](http://www.eon-uk.com).

This media strategy resulted in high support levels (about 90%).<sup>98</sup>

EROWL's main messages to promote offshore wind energy:

- Benefit of CO<sub>2</sub> reduction – 75,000 tonnes of potentially harmful greenhouse gases are prevented each year.
- Contribution to energy supply – enough 'green' electricity will be generated to power 41,000 homes.
- The local economy will receive a boost during the wind farm's construction. Local employment opportunities are expected for the team that will operate and maintain the wind farm.
- Foundations for the turbines act as an artificial reef on the seabed, which supports marine life in the area. The environment, the community and local wildlife will benefit from the presence of the wind farm.
- The wind farm will provide another unusual feature on the Norfolk coastline for the tourist trade.
- The turbines themselves will act as a useful navigational aid for a currently unmarked shipping hazard.



Source: E.ON – UK, Chatterton

Figure 9-3: Scroby Sands Information Centre in Great Yarmouth<sup>99</sup>.

EROWL focussed on the needs of pupping seals and the breeding season of the little tern colony. A construction methodology was developed in conjunction with the Royal Society for the Protection of Birds and the Sea Mammal Research Unit at the University of St. Andrews. Information about the

<sup>98</sup> Dan Woodmann, ODE, private communication, November 2005

<sup>99</sup> Adrian Chatterton, "Scroby Sands", E.ON UK Renewables, November 2005

issue was presented at a public exhibition (350 – 400 visitors over two days) to people who had environmental concerns about seals and the little tern colony.<sup>100</sup>

***Planning (legislative):***

The approval procedure for the wind farm site and grid connection involves the following steps:<sup>101</sup>

- Crown Estate pre-qualification in April 2001
- DTLR - Section 34 Coast Protection Act 1949
- DEFRA - Section 5 Food and Environment Protection Act 1985
- DTI - Section 36 Electricity Act 1989
- General Permitted Development Order

The licence for Scroby Sand regulates conditions relating to the construction, equipment and operation of the vessels: detailed regulations exist regarding the necessary equipment of the employed vessels and their identification and communication facilities.

The detailed frequency and duration of investigations of environmental impact are regulated in the licence. The environmental impact assessment<sup>102</sup> includes:

- Seals and birds
- Benthic assessment
- Fisheries assessment
- Sand bank and coastal geomorphology
- Wave climate
- Marine archaeology
- Noise assessment
- Navigation, traffic and shipping
- Aviation, television, radio and radar

***Environmental monitoring:***

The licence for Scroby Sand was issued by the Secretary of State for Environment, Food and Rural Affairs on 17 April 2002 to Powergen Renewables Offshore Wind Ltd<sup>103</sup> (now EROWL).

The environmental investigations are supplementary conditions to the licences. The various impacts of the wind farm have to be investigated (details see Table 9-3). These include:

- Sedimentary and hydrological processes
- Beach profile and geomorphology
- Benthos
- Scour
- Ornithological monitoring
- Seals
- Noise and vibration

---

<sup>100</sup> BWEA “Best practise guidelines: Consultation for offshore wind energy< developments”, , 2002

<sup>101</sup> [www.eon-uk.com](http://www.eon-uk.com) –Scroby Sands Offshore Wind Farm

<sup>102</sup> *ibid*

<sup>103</sup> Marine Consents and Environment Unit “Licence No 31272/02/0”, 17 April 2002

EROWL has to follow several general conditions:

- Assurance of use of approved agents for anti-fouling treatment and paints
- Removal of any temporary structures from the foreshore/seabed on completion of the work
- Precautions taken to protect the water column during the construction process

Powergen has to submit annual progress reports. The conditions may be changed by the Licensing Authority upon request by EROWL, but the licence may also be substantially re-assessed or even revoked.

Table 9-3: Scope and duration of environmental monitoring programmes at Scroby Sand offshore wind farm<sup>104</sup>

Programme	Year of monitoring
Sedimentary and hydrological processes ; Fieldwork studies by CEFAS	First report: pre-construction Second report: post-construction Third report: during the second post-construction monitoring period
Beach profile and geomorphology	Similar to the sediment monitoring , after one year the monitoring frequencies are reviewed
Benthos	Post-construction benthic monitoring, samples at 54 sampling points <sup>105</sup>
Scour	Half-yearly intervals during the first three years after completion → new licence necessary if further scour protection is required
Ornithological monitoring of little terns	No disturbances from May to July Little tern feeding studies, breeding colony studies Prey studies: annually throughout pre-construction phase Annual throughout construction phase In the operational phase: minimum of 3 years of data, dependent upon outcome of current studies by NERI Decommissioning phase: depending upon the unclear/negative impacts recognised from construction phase
Seals	2 fly-overs per month at low water for six summer months pre-construction, construction and post-construction
Noise and vibration	Proposals for measuring sub-sea noise and vibration

#### ***Sedimentary and hydrological processes:***

The licence for Scroby Sand defined a monitoring strategy to analyse sedimentary and hydrological processes. It followed four aims:

- Collection of a unique dataset of waves/currents on sandbanks for use in calibration
- Quantification of sediment transport during winter and summer seasons and comparison with any impact due to wind farm construction
- Suspended sediment monitoring
- Liaison with numerical models

<sup>104</sup> *ibid*

<sup>105</sup> *ibid*; see Appendix 1: Station Type and Positions

The licence contains detailed information about the monitoring instruments, such as a directional wave gauge and bathymetric and side scan surveys.

The monitoring periods are fixed for:

- A one-month-period in summer and in winter within the pre-construction period
- A one-month-period in summer and in winter during the construction / post-construction periods

The communication strategy with fishermen is part of the licence of the Secretary of State for Environment, Food and Rural Affairs; consultation with the Maritime and the Coastguard Agency is also part of the supplementary conditions. An onshore liaison officer shall be appointed to develop and maintain effective communications between EROWL, contractors and fisherman, and other users of the sea during the project. Intensive communication is stipulated, particularly with local fisherman via the District Inspector of Fisheries.

### **Generic environmental research:**

The Crown Estate funds generic environmental research projects. The fund is financed through deposits by all wind farm developers in Round 1. The deposit is paid as part of the lease agreement with Crown Estate.

A steering group administers the fund. Members have environmental, nature conservation and industry expertise (English Nature, Countryside Council for Wales, Joint Nature Conservation Committee, CEFAS, Royal Society for the Protection of Birds, Department for Trade and Industry (DTI), Department for Environment, Food and Rural Affairs (Defra) and the British Wind Energy Association). The steering group drew up a priority list of research projects. Four were chosen for action:<sup>106</sup>

- Potential effects of electromagnetic fields from offshore wind farm cables on electro-sensitive fish
- A comparison of ship-borne and aerial sampling methods for marine birds and their applicability to offshore wind farm assessments
- Predicting the displacement of common scoter *Melanitta nigra* from benthic feeding areas due to offshore wind farms
- Assessment of sub-sea acoustic noise and vibration from offshore wind turbines and its impact on marine mammals

The Centre for Environment, Fisheries and Aquaculture Science is undertaking the following research projects at the Scroby Sands offshore wind farm:<sup>107</sup>

- Assessment of the significance of changes to the inshore wave regime as a consequence of an offshore wind farm array
- Development of generic guidance for sediment transport-monitoring programmes in response to the construction of offshore wind farms

The projects are funded by the UK government's Department for Environment, Food and Rural Affairs (Defra). Further information are available under <http://www.cefasc.co.uk/renewables> and [www.crownestate.co.uk](http://www.crownestate.co.uk).

---

<sup>106</sup> Adrian Judd "Offshore wind parks in Great Britain and the project Collaborative Offshore Wind Research into the Environment (COWRIE)" *Centre for Environment, Fisheries and Aquaculture Science (CEFAS)*, [www.erneuerbare-energien.de](http://www.erneuerbare-energien.de)

<sup>107</sup> *ibid*

### 9.2.2 Economics

Total costs of the Scroby Sands project (including five years of O&M) amount to £ 80 million<sup>108</sup>. The following data are taken from Douglas Westwood's "Scroby Sands - Supply Chain analysis",<sup>109</sup> detailing the costs during the main project phases (see Table 9-4) and development, construction and operation phase (see Table 9-5). EROWL received a £ 10 million government grant.<sup>110</sup>

Table 9-4: Scroby Sands - value by phase<sup>111</sup>.

Phase	Total (£ '000s)	Percentage %
Development	1,737	2.2
Construction	71,511	89.3
Operations	6,825	8.5
Total	80,073	100

Only 2.2% of the budget was spent during the development phase:

- Development design (consultancy, development agreement, electrical system studies, FEPA license application, section 36 planning application, site management, staff costs)
- Environmental monitoring (environmental surveys)
- Insurance/legal fees
- Surveys (geotechnical survey / investigation, site surveys)
- Miscellaneous (reprographics)

The construction phase started in 2003 and continued over a two-year period. 89.3% of the budget was expended for:

- Environmental monitoring (surveys - aerial, bird & coastal bird protection, environmental management, noise monitoring)
- Insurance/legal (construction insurance, legal / easements, site inspection)
- Site surveys
- Project management (board & lodging, HSE site rep, offshore installation, onshore logistics, planning supervisor, project administration, quality assurance)
- Detailed design electrical (foundation, SCADA, scour, surveys)
- Procurement & manufacturing (blades, cables, logistic support, monopiles, nacelle, onshore cable supply, towers)
- Transport & delivery (blades, facility – harbour, harbour dues, nacelles, parts, surveys, towers)
- Onshore pre-assembly (blade handling, cranes, labour, onshore equipment, quay rental, site transport)
- Onshore installation (onshore cable installation, substation / grid interface)

<sup>108</sup> Douglas Westwood and ode operations "Scroby Sands- Supply Chain analysis", DWL Report Number 334-04, July 2005, page 11

<sup>109</sup> *ibid*

<sup>110</sup> Adrian Chatterton, E.ON UK Renewables, private communication, Copenhagen, 27 October 2005

<sup>111</sup> Douglas Westwood and ode operations "Scroby Sands- Supply Chain analysis", DWL Report Number 334-04, July 2005, Table 4-2

- Offshore installation (export cables, inter array cables, piles, scour protection, turbines)
- Commissioning (senior authorised personnel, superintendents, transfer vessels, weather forecasts)
- Miscellaneous (information centre building works, project film/photography, training, visitor centre design & fit out)

The remaining 8.5% is budgeted for five years of operations & maintenance (project management, site management, service personnel, service vessels, replacement components, other operational costs).

Table 9-5: Details of costs in development, construction and operation phase of Scroby Sands offshore wind farm<sup>112</sup>

Phase	Total (£'000s)	Percentage %
Development phase:	1'737	100
○ Development design consultancy	1'409	81,1
○ Environmental monitoring	30	1,7
○ Insurance/legal fees	33	1,9
○ Surveys	173	10,0
○ Miscellaneous	92	5,3
Construction phase:	71'512	100
○ Environmental monitoring	160	0,2
○ Insurance/legal	1'747	2,4
○ Site surveys	087	0,1
○ Project management	4'551	6,4
○ Detailed design electrical	1'111	1,6
○ Procurement & manufacture	38'986	54,5
○ Transport & delivery	1'225	1,7
○ Onshore pre-assembly	2'200	3,1
○ Onshore installation	1'825	2,6
○ Offshore installation	16'700	23,4
○ Commissioning	2'175	3,0
○ Miscellaneous	745	1,0
Operations & maintenance (5 years):	6'825	100

The value of the main components of the offshore wind farm (blades, cables, grid interfaces, nacelles, piles, towers and indirect costs) are shown in Table 9-6. The nacelles and piles each have a value of about one third of the full value of the construction phase; cables account for 12% and towers about 7%.

<sup>112</sup> *ibid*; Tables 4-6, 4-8 and 4-12

Table 9-6: Scroby Sands - value of the main components during the construction phase<sup>113</sup>

Component	Total (£'000s)	Percentage %
Blades	6'450	9,0
Cables	8'627	12,1
Grid interfaces	645	0,9
Nacelles	22'175	31,0
Piles	19'565	27,4
Towers	4'775	6,7
Indirect costs	9'274	13,0
Total	71'511	100

The overall person-hours differ widely during the phases of the wind farm. Many jobs were created for a relatively short period of time, particularly during the construction phase (see Figure 9-4). This leads to a discontinuous mode of production and may cause problems for the companies which produce the main equipment. A steady series of developments and some degree of work continuity is important to maintain sustained employment. Companies producing the piles for the Scroby Sands project faced these difficulties; sustainable market development, i.e. a series of wind farms, can help to avoid them.

During the operation phase of the wind farm, 10 permanent jobs were created within the Vestas Celtic operation and maintenance contract.<sup>114</sup>

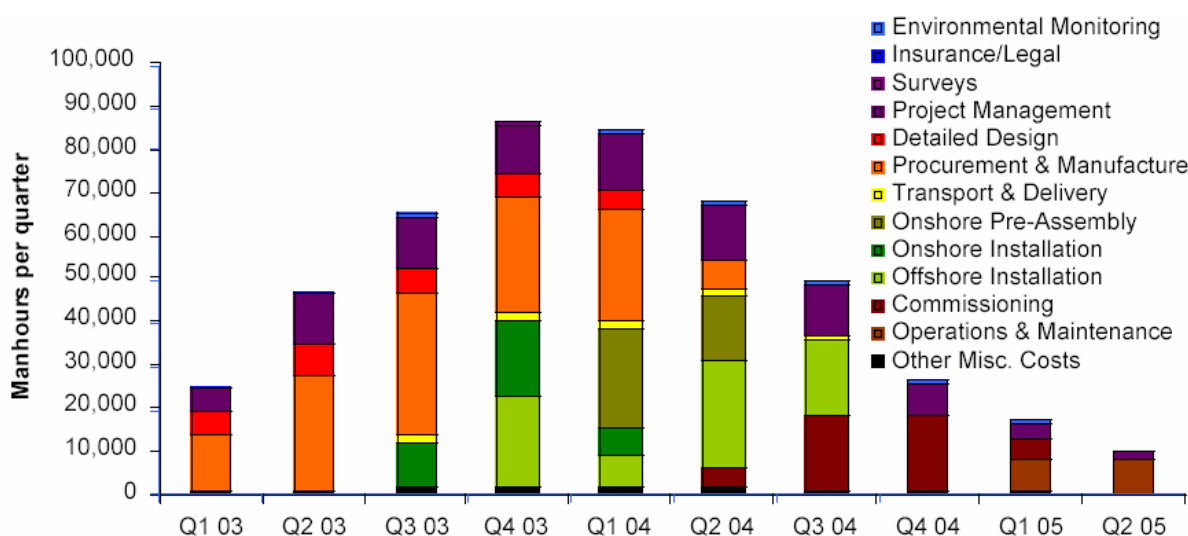
Figure 9-4: Scroby Sands – Man-hours during construction and operation phase (2003 – 2005)<sup>115</sup>.<sup>113</sup> ibid; Table 4-6<sup>114</sup> ibid; July 2005, Page 30<sup>115</sup> ibid; Figure 4-4

### 9.2.3 Technology

The project was prepared through basic technical studies.<sup>116</sup> The works started with site assessment in 1993-1994. In 1995 an anemometry mast was installed to provide data about wind resources. The site was chosen because of the good port facilities at Great Yarmouth and good grid connection facilities. Other studies covered the following aspects:

- Seismic, bathymetry and test bore studies
- Metocean data collection
- Export cable route planning
- Site electrical infrastructure
- Detailed foundation design

The Vestas technology was chosen because its good references and price. Details of the turbine technology were in the responsibility of Vestas.

#### ***Foundations:***

Gravity foundations were not considered to be suitable for Scroby Sands.

To determine wall thickness and penetration depth of monopoles, dynamic analyses were carried out. The analysis included vibrational behaviour of the pile, as well as wave and wind loads. The piles were designed to resist peak storm and fatigue loads for their operational lifetimes. The integrated boat landing, with access platform and J-tube arrangement, was analysed for the waves and current at the location. The boat landing includes two access ladders, to accommodate boat approach from different directions. The pile has an internal work platform near the top of the pile.

The monopiles, with a diameter of 4.2 m, were pre-fitted with welded flanges on the top for connection to the tower. They were installed in a pure pile-driving operation. The hammer anvil was placed directly on the welded flange on top of the pile. No additional grouting was necessary. The boat landing and access platform was installed immediately after pile-driving. Offshore operations are simplified. This cost-efficient design was used for the first time at Scroby Sands.

A jack-up rig transported the piles (up to 200 t per pile) and steel structures to the construction site, which simplified logistics and minimised the number of offshore operations.

The total installation time for one foundation was around 24 hours.

#### ***Location of turbines:***

The turbine stand in three rows, but not in line. The turbine locations depended on the seabed and the location of the sandbank (see Figure 9-5).

---

<sup>116</sup> [www.eon-uk.com](http://www.eon-uk.com)

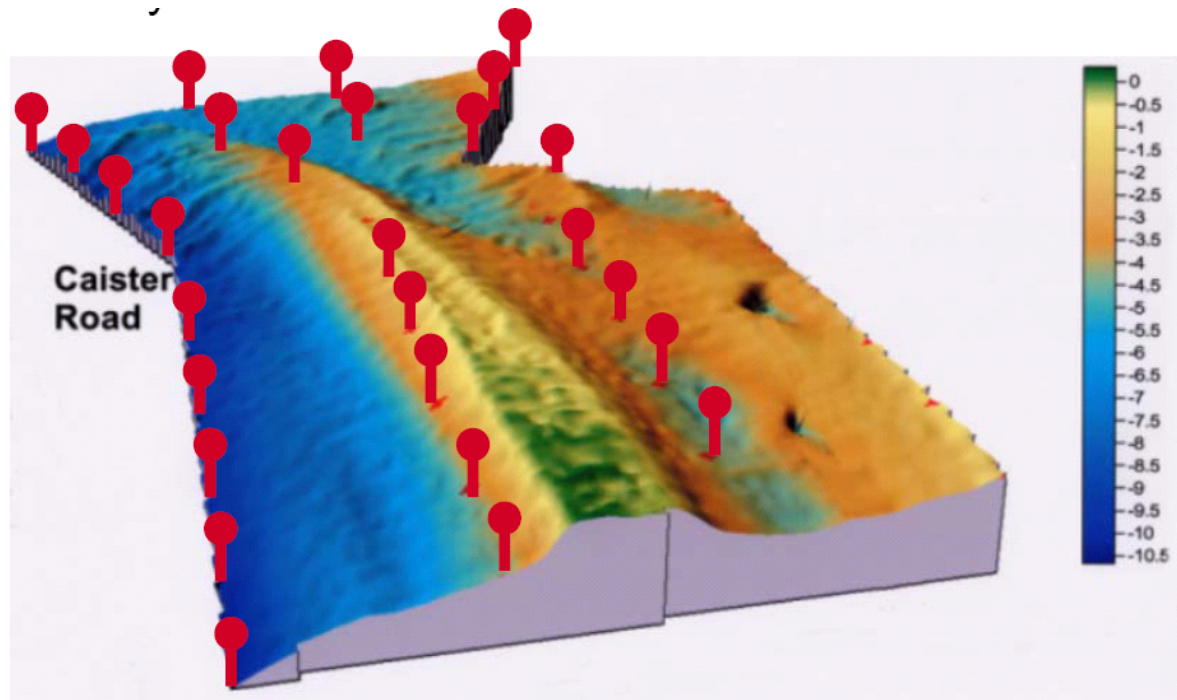

Figure 9-5. Location of turbines at Scroby Sands<sup>117</sup>.

#### ***Scour protection:***

The Scroby Sands wind farm is located on an enormous sand bank. It is formed by the large tides (range 3 m, tidal velocities up to 1.5 m/s). In a 30-year period, the sea bottom changes 8 m (this figure has been measured over 150 years by the British Admiralty). The very large seabed subsidence and the potential very deep scour hole of 6-8 m made a scour protection necessary. In particular, it was necessary to protect the power cables. The selected scour protection material is comprised of stones. The scour protection was installed made by dumping the stone from a side-dumping barge. To distribute the material around the pile, side-dumping took place from six different directions. Unloading started at a distance of 2 m from the pile, and the barge was then moved away from the pile while unloading.<sup>118</sup>

#### ***Grid connection:***

An appropriate route for the cable from the wind farm to the substation was agreed in consultation with the local harbourmaster, the Port Authority, fisherman and the local Borough Council.<sup>119</sup> The agreed route is shown in Figure 9-6.

No transformer station was built offshore. Three cables of 33 kV each transport the energy to shore. Each cable collects the energy of 10 wind turbines. These three cables are connected offshore with a by-pass.

*AEI Cables* supplied the following cables for Scroby Sands:<sup>120</sup>

- Links to shore – 33 kV 300 mm<sup>2</sup> double-armoured

<sup>117</sup> Hansen and Gislason

<sup>118</sup> Niels-Erik Ottensen Hansen and Kjartan Gislason “Movable Scour protection on highly erodible sea bottom”, Hellerup, Denmark

<sup>119</sup> BWEA “Best practise guidelines: Consultation for offshore wind energy developments”, 2002

<sup>120</sup> [www.wt-henley.com](http://www.wt-henley.com), October 2005

- Turbine interconnections – 33 kV 240 mm<sup>2</sup> single-armoured

*Pirelli Cables Ltd* delivered the:

- 33 kV single core 500 mm<sup>2</sup> CWS land to be connected to the offshore cables at the ‘beach head joining pit’ and terminated at the ‘EDF Energy grid substation at Admiralty Road’.



Figure 9-6: Cable to Shore from Scroby Sands Offshore Wind Farm to Substation<sup>121</sup>.

## 9.3 Installation and operation phase

### 9.3.1 Installation and grid connection

#### *Piling Operation*

Mammoet Van Oord employed the JUMPING JACK jack-up barge to conduct foundation installation works. The project consisted of the installation of 30 monopile foundations.<sup>122</sup>

The monopiles, with a diameter of 4.0 metres, were installed by a pure pile-driving operation. The hydraulic hammer (IHC S1200) was placed directly on the welded flange on the top of the pile.<sup>123</sup>

#### *Installation of tower, turbine, rotor blade:*

A2SEA Ltd installed the 30 units, together with Seacore Ltd, using the vessel MV OCEAN ADY and the Seacore’s jack-up Excalibur. MV OCEAN ADY is based on a unique concept which combines a 450 t sea-stabilised crane with a fast sea transport unit.<sup>124</sup> Seacore designed and fabricated the jack-up Excalibur to carry 2 complete wind turbine generators. The hub height is 60 m.<sup>125</sup>

A2SEA A/S installed 24 turbines (started 26 March 2004 and completed 14 May 2004) in deeper water. Seacore Ltd installed 6 turbines (12-day programme with the last turbine completed by 1 June 2004<sup>126</sup>) in shallow water.

<sup>121</sup> [www.eon-uk.com](http://www.eon-uk.com), October 2005

<sup>122</sup> [www.mammoetvanoord.com](http://www.mammoetvanoord.com), October 2005

<sup>123</sup> [www.ihcholland.com](http://www.ihcholland.com), Annual Report 2003, October 2005

<sup>124</sup> EWEA “EWEC 2004”, [www.ewea.org](http://www.ewea.org), October 2005

<sup>125</sup> Seacore “Project: Scroby Sands”, [www.seacore.co.uk](http://www.seacore.co.uk), October 2005

<sup>126</sup> [www.a2sea.com](http://www.a2sea.com), October 2005

**Cable installation:**

The sub-sea cabling proved to be time-consuming. Weather data were not always sufficient to decide whether to start and continue work. The process of laying three cables on the seabed had to be interrupted for one of the cables.

Diver intervention was limited by strong tidal currents. The data on currents were insufficient in some cases.



Elements at quayside;  
Source: E.ON UK, Chatterton



Nacelles;  
Source: E.ON UK, Chatterton



Elements at quayside;  
Source: E.ON UK, Chatterton



Loaded vessel leaves Harbour Lowestoft;  
Source: Woodmann, ODE

Figure 9-7: Harbour logistics in Lowestoft <sup>127</sup>.

**Logistical aspects:**

Turbines were assembled at Vestas' factory at Campeltown. The turbines/blades were pre-assembled by Vestas Celtic at SLP Engineering's Lowestoft port. Other logistics were organised via the harbour of Great Yarmouth.

<sup>127</sup> [www.eon-uk.com](http://www.eon-uk.com)

### 9.3.2 Operation

The testing procedure included 24-hour reliability runs for each wind turbine, as well as 120-hour reliability testing for the entire wind farm. The testing procedure lasted 6 months. *Vestas* and *ode* were responsible for various testing procedures and the documentation of results.<sup>128</sup>

#### ***Access to turbines (transport and approach):***

Access to turbines is direct by boat. Accessibility depends on wave height (maximum 1.5 m).<sup>129</sup>

Alnmaritec, a division of TTS Ltd, designed a small boat specifically to service the offshore wind farm at Scroby Sands. The craft offers seating for 12 passengers and 2 crew, plus ample deck space for cargo.

The craft will be used to transport maintenance operators and tool kits to and from the offshore wind farm. The vessel has a large overhang at the bow to allow for ease of disembarkation to the wind turbines. The vessel was fitted with a 2.4 MT crane to allow cargo to be carried and manoeuvred. The craft is constructed to sail 3-20 miles from a safe harbour, which enables it to work at the offshore wind farm at Scroby Sands.<sup>130</sup>



Access to pile; source: E.ON-UK<sup>131</sup>



Length overall: 14.150 m

Beam (over hulls): 5.20m

Draft light 0.60m

Displacement light approx. 13.5 tonnes

Speed approx. 18 knots

Source: <http://www.alnmaritec.co.uk>

Figure 9-8: Small Boat Access to Scroby Sands Offshore Wind Farm.

<sup>128</sup> Dan Woodmann, ODE, private communication, November 2005

<sup>129</sup> *ibid*

<sup>130</sup> [www.alnmaritec.co.uk](http://www.alnmaritec.co.uk), November 2005

<sup>131</sup> [www.eon-uk.com](http://www.eon-uk.com), November 2005

### ***Availability and generation of electricity***

From January to August 2005, availability of the wind farm rose from 83% to 96%. The generation of electricity varied between 22 GWh in January 2005 and 12 GWh in August 2005 (see Figure 9-9). The aim is to produce 171 GWh per year.

Availability

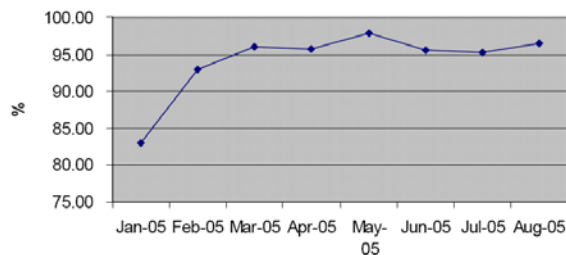

Generation

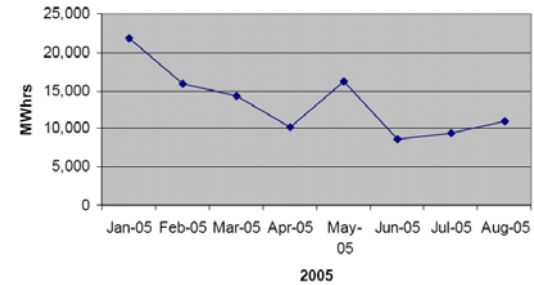

Figure 9-9: Availability and Generation of Electricity at Scroby Sands Wind Farm<sup>132</sup>.

## **9.4 Lessons learnt**

The wind farm was one of the first projects in the UK territorial waters. In general, Scroby Sands was a successful project.

The main obstacles in planning and realising the project were lack of experience and underestimation of time required to plan the project. The time schedule was unrealistically short at the start of the project. The tendering period was only six weeks, and the process had to be repeated as a result.

The sub-sea cabling proved to be time-consuming and diver intervention was limited by strong tidal currents. Commissioning was delayed by unseasonable weather (in particular, autumn weather frustrates small boat access). The construction of J-tubes was not sufficient. J-tube scour holes were not developed when the appurtenances were installed.

Jobs were created at some companies for a relatively short period of time to produce the main elements of the wind farm. As a result, there was little or no other similar work in the marketplace when the piles were completed.

The most important lessons learnt were:

- Ratify design prior to procurement. Involve system designers / fabricators in the planning process.
- Factory acceptance tests (FAT) should be comprehensive. They are valuable to clients and contractors, because problems can be fixed more cost-effectively at the factory (5 times less than off-shore).
- Sufficient data: geotechnical, possible tidal and wave rider, ordnance surveys and information on submerged objects are necessary to plan.
- Two seasons for piling installation and turbine installation resulted in buffer time for project completion.
- Two companies manufactured piles. This allowed enough lead time and improved design (welded flanges on the top for connection to the tower, pure pile-driving operation possible).

<sup>132</sup> ibid

- Different installation vessels were necessary to install turbines in shallow and deep water.
- Weather window for cabling and commissioning should not be too short and take into account bad weather in summer.
- Early and broad involvement of stakeholders, project charities and an information centre led to high public acceptance, although the project is located just 2.5 km off the coast.
- Take more consideration of anchor plans due to inter-array cables, especially for larger wind farms.
- Include water-blocking protection in the cable.
- High-voltage switch gear should allow remote control, for improved health and safety.
- One person should be responsible for commissioning and testing. This person should be the focal point of all aspects. The task should include producing documentation and providing personnel.
- Small boat access for commissioning should be given greater consideration due to inclement weather periods, even in summer.
- Test procedures should be agreed upon in advance (what shall be tested and how).
- Ensure that the SCADA system uses open standards which can be transferred to new hardware and software (because IT systems become obsolete notoriously quickly).
- Operation and maintenance created 15 permanent jobs.
- A steady series of developments and increased demand is necessary for manufacturers to provide some level of continuity of work and sustained employment.

## 10 Summary - Lessons learnt

The planning and construction of offshore wind farms is quite different from the development procedure for onshore wind farms. New experiences will have to be gained. The planning of an offshore wind farm is nearly as complex as a conventional power plant. The combination of electrical power generation and offshore technology is quite new and challenging.

The main message from interviews and discussions with offshore wind farm developers, relevant ministries and engineering companies is that the planning for procurement, installation, commissioning and operation is ambitious. The procedures can be improved. In the following, the main conclusions are summarised.

### 10.1 The main steps in the planning and realisation of offshore wind farms

From the information gathered, seven main steps could be identified for the planning and realisation of offshore wind farms:

- Pre-project planning,
- Detailed project planning,
- Engineering, testing, production and procurement,
- Installation and commissioning,
- Full operation,
- Repowering and
- Dismantling.

Each of these phases consists of several important work packages, summarised in Table 10-1. To be successful, the project management must take these work packages into account. The logical work flow of the project is shown in Figure 1, with an overview of the connections between the main phases. This flow chart shows one possibility for the planning and realisation of offshore wind farms.

Table 10-1: Important work packages during the main phases of offshore wind farm planning and realisation.

<b>Pre-Project Planning</b>	
<ul style="list-style-type: none"> <li>○ Pre-feasibility study (wind farm technology, grid connection and technology, stakeholder involvement, embedding in spatial planning, supply chain management, logistics, economic assessment of main supplies and construction works, environmental and public impacts)</li> <li>○ Development of strategies (financing, media, stakeholder involvement, approval) and project structure</li> </ul>	
<b>Detailed Project Planning</b>	
Project approval procedure	<ul style="list-style-type: none"> <li>○ Wind farm</li> <li>○ Grid connection</li> <li>○ Where necessary: grid extension and reinforcement (or appropriate measures e.g. wind energy production management)</li> </ul>
Site investigation	Geographical, wind speed and wind direction, oceanographical, chemical, geological and biological
Definition of functional requirements of main elements of the wind farm	<ul style="list-style-type: none"> <li>○ Wind farm infrastructure</li> <li>○ Electrical infrastructure</li> <li>○ Harbour logistics</li> <li>○ Offshore logistics</li> <li>○ Health, safety and environment</li> </ul>
Planning of internal controlling system and master plan	<ul style="list-style-type: none"> <li>○ Key performance indicators</li> <li>○ Quality assurance and control</li> <li>○ Factory acceptance tests</li> <li>○ Reporting system</li> <li>○ Interface management</li> </ul>
Tender process	Preparation of documents, elaboration of proposals, tender evaluation and sub-contractors' negotiation
Others	Master Plan (comprehensive plan that describes and maps the overall development concept of the project), financing and insurance arrangements, contracting
<b>Engineering, Testing, Production and Procurement</b>	
Engineering and planning	<ul style="list-style-type: none"> <li>○ Pre-testing</li> <li>○ Installation</li> <li>○ Commissioning</li> <li>○ Operation, and</li> <li>○ Dismantling</li> </ul>
Pre-testing and training	<ul style="list-style-type: none"> <li>○ Testing of full size model of wind turbine</li> <li>○ Service and maintenance of main components (pile, nacelle, blade, generator, transformer)</li> <li>○ Access to wind turbine, and</li> <li>○ Training courses for personnel</li> </ul>
Production and procurement	<ul style="list-style-type: none"> <li>○ Production of wind farm elements</li> <li>○ Interface and work flow management</li> <li>○ Quality assurance and control</li> <li>○ Factory acceptance tests, and</li> <li>○ Transport to logistical centre</li> </ul>
<b>Installation and Commissioning</b>	
<ul style="list-style-type: none"> <li>○ Site preparation, pre-assembly of parts in harbour, installation of foundation for wind turbines and transformer station</li> <li>○ Installation of groups of wind turbines (installation of piles, nacelles and blades, inter-array cable laying and testing)</li> <li>○ Installation of electrical infrastructure offshore and onshore (transformer station, cable to shore laying and grid connection infrastructure to public energy supply)</li> <li>○ Commissioning of supervisory control and data acquisition system (SCADA), final testing of wind farm, environmental monitoring of construction phase</li> </ul>	
<b>Full Operation</b>	
<ul style="list-style-type: none"> <li>○ Service and maintenance</li> <li>○ Environmental monitoring of operation phase</li> </ul>	
<b>Repowering</b>	<b>Dismantling</b>

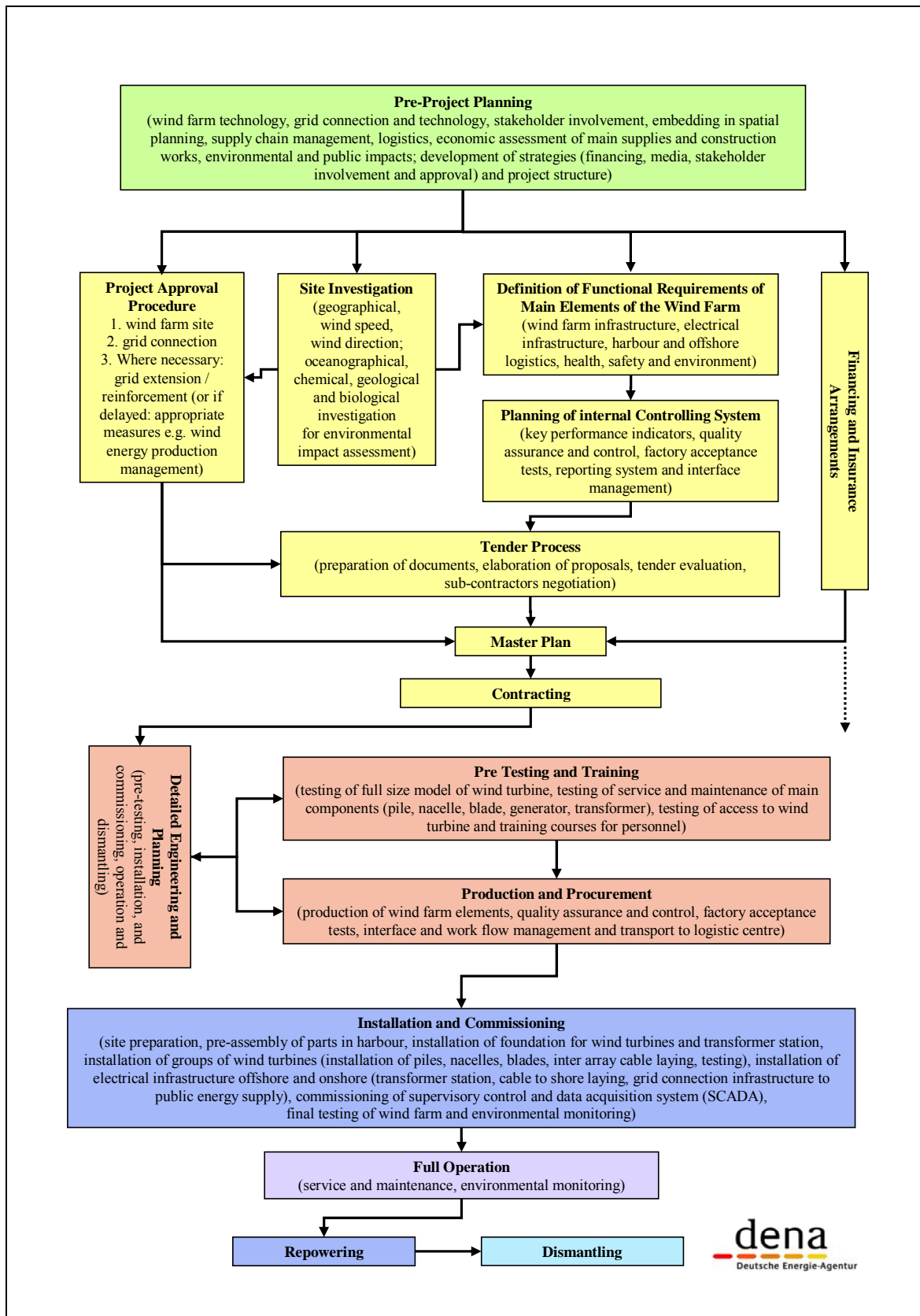

Figure 10-1: Flow chart of the main work packages for the phases of offshore wind farm planning and realisation.

## 10.2 Pre-planning, project planning, management and approval

Direct governmental involvement can generally be positive, as it enables sound spatial planning by identifying the most suitable areas for offshore wind farm installation and avoiding major conflict zones. National planning can in fact lead to the determination of the most appropriate areas. A screening process can contribute to minimising potential conflict.

On the other hand, it can be seen that direct governmental involvement in selecting sites for offshore wind farms can also have a disadvantageous effect if the government does not allow for a certain degree of flexibility in permit requirements, procedures etc. By selecting the wind farm site and determining the technical framework strictly, final technical optimisation has not proven possible. Sticking to previously set site conditions, which may be outdated by modern technological developments, does not permit the area available for wind farms to be optimally used, with optimal turbine spacing and technology.

The characteristics for the first projects has been an often step-by-step planning procedure, which has shifted the focus of work efforts after finalisation from one approval issue to the next. With increased experience, it can be expected that ever more of the planning and approval procedures can be done in parallel, which will speed up the planning and implementation process. Also, offshore and onshore work packages can be performed in parallel.

A major advantage in the approval phase is the existence of just *one* major approval authority, responsible for and managing the entire approval procedure. If approval is not well coordinated, several authorities may have to be addressed for different approval matters in the EEZ: The approval for the grid connection would have to be split up into offshore EEZ, offshore 12-nmi zone and onshore cable route. For the approval in the 12-nmi zone, again, different authorities would participated in the approval process. This would lead to time consuming and expensive procedures, which could better be streamlined.

Stakeholder involvement and implementation of media strategy can avoid many potential conflicts, and thus preclude opposition to projects. Stakeholder involvement should be given high priority in the pre-planning phase of a project.

From the projects realised, it can be gathered that the main obstacles in the planning and realisation of projects were a lack of experience on the part of planning authorities, or of project developers, and underestimation of the time required to plan the project, i.e., for the tender process.

### Recommendations:

- The pre-selection of sites by authorities in the framework of a screening process provides major advantage for the approval process. It helps avoid conflicts, unnecessary approval procedures and site investigations. Moreover the approval process can be accelerated and a higher level of planning safety for the project developer can be reached.
- The approval should give as much flexibility to the developer to decide which technology to use, e.g which type of multi-megawatt wind turbine generators to install. This will allow the developer to benefit from a rapid engineering process.
- During the “detailed project planning” phase some work packages should be realised in parallel, because they are a prerequisite for the tendering process and the contracting: project approval procedure, the site investigation, and the definition of functional requirements of major elements of the wind farm.
- In light of the positive experiences of the Nysted Offshore Wind Farm, the project planning process should take into account the following work packages: pre-testing of a full sized wind turbine model, testing of the service and maintenance of the main components (the pile, the nacelle, the blade, the generator, and the transformer), testing of access to the wind turbine, and training courses for the personnel. These work packages should be completed and evaluated before the production of wind farm elements starts.

- The appointment of a single leading authority for the complete approval process is of high value for both, the planning authorities and the project developers. The approval process is streamlined, avoiding a number of discrepancies and a considerable amount of organisational effort for the planning party. One of the main benefits is the single approval process for the offshore EEZ, the offshore 12-nmi zone and the onshore grid connection and cable route. A “one-stop shop” office approach is recommended.
- A governmental screening process as performed in Denmark allows the best selection of suitable offshore sites with minimum impact to the environment, nature and other concurring uses, while at the same time providing a high level of planning safety for the developing company.
- A professional media strategy is helpful for increasing public awareness of offshore wind farms in general, and also for specific projects. Media campaigns can be valuable for raising public acceptance, particularly with regard to tourism and nature impact issues.
- A media strategy can be improved for many offshore wind farm projects. Websites, information centres, newsletter and press information can contribute to creating a positive image.

### 10.3 Procurement and contracting

Either the wind farm is delivered as a turnkey object under an EPC contract, or the project developer or owner places orders separately for the main project tasks (multi-contractual approach). In the first case, the EPC is the sole contractor with the wind farm owner, and must bear all risks and warranties. It places orders with different subcontractors and tries to pass on the risks and warranties to each of them. As the offshore wind energy business still faces relatively high uncertainties for the installation process (mainly weather), the resulting cumulated risk is rather high.

In the latter case, the multi-contractual approach, the orders for the individual building segments are placed directly by the future owner. While the risks in the individual segments are basically the same as in the first case, the cumulative risks faced by the future owner may be reduced, due to the presence of overall risk management for the entire project.

Some projects simply could not cope with the preparations for such a project, and depended on external expertise and knowledge on this. For them, there was no choice other than EPC.

The complete installation procedure of an offshore wind farm requires different individual steps, from turbine manufacturing to the start of operations. The outline of this procedure is depicted in Figure 10-2. To reduce the costs of the construction process, the interfaces between the various projects steps, from manufacturing to commissioning, should be kept as smooth as possible. Each interface within this chain of project steps is associated with a number of expenses – for documentation hand-off, inspections, insurance, damage assessment and clarification etc.. To limit these expenses, the process from initial transportation to the installation harbour up to installation of the turbines at sea could be performed by a single company.

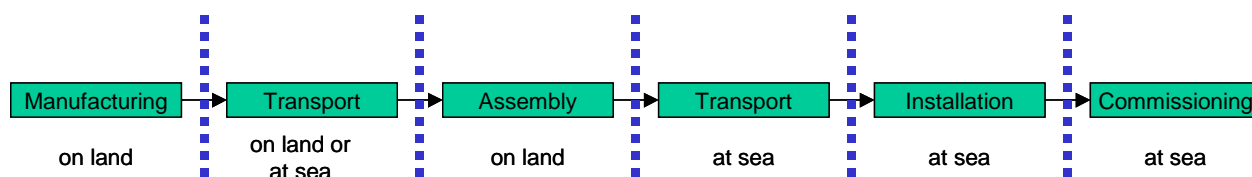

Figure 10-2: Single steps in the completion of offshore wind farms, from manufacturing to start of operation. An interface may be required between each step.

#### Recommendations:

- From the various discussions in the framework of this study, an economic advantage could be identified for multi-contractual structures for the procurement of offshore wind farms. As the provider of EPC contracts have to take on all installation risks, including all difficulties caused by bad weather, covering this risk requires a higher sales price – as much as 20 % more. Therefore, the multi-contractual project concept would seem to have clear financial benefits for the developer. On the other hand, the developer must be able to control and manage the entire procurement, installation and commission process, and to deal with weather risks, as well as to share the resulting extra costs. Further evaluation and research work should be carried out in order to gain information on the important issue as to whether EPC or multi-contractual structures is preferable from an economic point of view.
- In the multi-contractual approach, the developer must have enough staff with sufficient knowledge during the planning and installation of all main elements of the project, including the reinforcement of the onshore transmission grid. The tender process requires technically highly detailed invitation and evaluation. The developer must control all interfaces between the different work packages and components, and should have full access to the contractors' design process and quality control. An excellent working relationship with the manufacturers is crucial to a successful project.

#### 10.4 Installation and Grid Connection

The first projects realised in Denmark revealed the need for drastic revision of the measures of onshore and offshore logistics. While the main difficulties were seen in the offshore logistics during the project planning phase, in fact, skilled offshore companies were able to plan, prepare and perform the works in a professional manner. By contrast, the onshore logistics for transport from manufacturers to the installation harbour and assembly and loading works in the harbour itself were far more complex than expected.

In general, the realised projects show that the testing of components and complete turbines is essential. Improvements, fixes and repairs which have to be done at already installed offshore turbines are vastly more expensive (five times more than onshore) and less cost effective than if they were performed onshore (or even in the manufactory). Factory acceptance tests should be quite comprehensive, as they are invaluable to clients and contractors.

The turbine manufacturer should test prototypes of blades and turbine as well as a fully equipped, full-size model of the lower tower section, and the developer and suppliers should agree upon testing procedures during the contracting phase.

Special attention should be paid to cable-laying for grid connection. Sea cable-laying is a widely-used technology today, but more for telecommunications purposes than for energy transfer. The characteristics of power cables are very different than those of communications cables: in most cases they are far heavier, stiffer and have a larger diameter. The laying of sea cables for the offshore wind farms has proved to be time-consuming, and the necessary diver intervention was restricted by strong tidal currents. The weather window for laying the cable and commissioning should be planned long enough in advance, and should take the potential for bad weather in summer into account.

Underestimation of onshore harbour logistics is a common and serious mistake during project planning. The increase in the sizes of areas leased for the assembly of a given number of turbines shows this development for onshore requirements. While the average gross installation time per turbine was not reduced significantly, Horns Rev already had nearly the same figure as the wind farms installed later. Table 10-2 shows some basic data on the space needed.

For the onshore logistics, it is important to know that as long as only a limited number of turbine installations are expected for a harbour, wind farm installation is a second-priority business compared

to such long-term activities as container shipping or other continuous marine business. The efforts to organise harbour logistics should not be underestimated: early planning by experienced project managers is urgently required.

Table 10-2: Installation of offshore wind farms (WF no. 4 is not yet built )

		1	2	3	4
<b>Wind farm</b>		<b>Horns Rev</b>	<b>Nysted</b>	<b>Scroby Sands</b>	<b>Egmond aan Zee</b>
<b>Number of turbines</b>	<b>[-]</b>	80	72	30	36
<b>Available installation site at harbour</b>	<b>[sq.m.]</b>	15,000	64,000	30,000	30,000
<b>Total time frame</b>	<b>[days]</b>	126	90	60	60
<b>Installation time</b>	<b>[days]</b>	105	81	55	55-90
<b>Travel time, one way</b>	<b>[hour]</b>	3	17	3	
<b>Gross installation time per turbine</b>	<b>[days/WTG]</b>	1.09	1,1	1,0	
<b>No. of installation vessels</b>		2	1	1	
<b>Required installation period</b>	<b>[days]</b>	87.2	79.2	30	

The numbers shown in Table 10-2 were derived from the three installed wind farms and one planned wind farm. The space typically required to assemble a turbine for offshore installation is 1000 sq.m. per WTG.

According to the experiences of installation companies, only 70 % of the days in a year are suitable for installation at sea at the listed wind farms. For wind farms, further out to sea, as most projects planned in Germany are, the time available for construction may be as low as 60 % (219 days). From the experience gained, A2SEA defined the following maximum wind speeds for installation (the main time period for installation often starts in the evening hours, when wind speeds calm down) as follows:

<b>Installation of</b>	<b>Wind speed range</b>
Tower and nacelle	10 – 12 m/s
Rotor blades	8 – 10 m/s

Table 10-3: Summary of the eight offshore wind farms investigated.

		1	2	3	4	5	6	7	8
Wind farm		Egmond aan Zee	Thornton Bank	Borkum West	Butendiek	Greater Gabbard	Horns Rev	Nysted	Scroby Sands
		Netherlands	Belgium	Germany	Germany	United Kingdom	Denmark	Denmark	United Kingdom
Number of turbines	[-]	36	6 / 24 / 60***	12 / 208	80	140	80	72	30
Turbine power	[MW]	3	3.6	5	3	3.6	2	2.3	2
Wind farm capacity	[MW]	108	21.6 / 120 / 300	60 / 1000	240	500	160	165.6	60
Turbine manufacturer	[-]	Vestas *	N.N.	N.N.	Vestas *	N.N.	Vestas	Bonus	Vestas
Expected annual production	[GWh/a]	345	986	260 / 4300		1750	600	480	171
Start of planning	[-]	2000-'02	2002	1999	2000		1998-'99	1998-'99	1993
Start of operation	[-]	2006*	2007*	2003* / 2010*	2008*	2009*	2003	2003	2004
Distance to land	[km]	10-18	27-30	45	34	23	14 - 20	9	3
Water depth	[m]	15-20	30	30	16-20	2.4 - 10	6 - 14	6 – 9.5	3 – 12
Investment costs	[mil. €]	200	100 // 500	138	420		238	250	116
Specific investment costs	[€/kW]		4630 // 1667** (3472 // 1583)	2300	1750 - 2000		1488	1510	1941
Subsidies	[mil. €]	27	30% grid cost, max. 25	-	-	-	grid cost covered	grid cost covered	-
Feed-in rate	[ct€/kWh]	9.7 + actual electricity rate	10.7 + actual electricity tariff	9.1 for 14 yrs. 6.19 rest	9.1 for 12 yrs 6.19 rest		5.77 for 11 yrs		Re

\* planned \*\* without and with subsidies \*\*\* different expansion phases

## 10.5 Economics

A general overview on the basic economic and technical figures of the investigated offshore wind farm projects is shown in Table 10-3. Not all figures could be made available for publication in this study, so that no general statements can be drawn from the Table. The differences in investment costs, subsidies, distance to land, water depth, subsidies for the grid connection and feed-in rates makes the economic comparison of the offshore wind farms quite difficult. The economic situation varies widely. Especially, the grid connection costs are the most impeding factor, as the distances to shore and thus the grid connection costs are very great. They can have a strong impact on the overall economic situation, and the decision of whether an offshore wind farm with high distance to land and high water depth is to be realised.

The total number of currently installed offshore wind farms is small, and very individual and specific factors influence the cost situation of these projects. Vast technological changes and new concepts for wind turbines and power transmission may be seen in future, which may have a significant influence on the costs situation as well. In addition, for some projects, the investment costs for grid connection are paid by the network operator or by the government. For some projects, direct subsidies for project monitoring are given by state authorities.

### Recommendations:

- Avoiding offshore work is important for the economics of offshore wind farm projects, because the costs of work in factories compared to work at quayside and to offshore work is about 1 : 3 : 5 or more – up to 10. Offshore work can be avoided by extended testing before the serial production of wind farm elements starts: testing of training courses for personnel, testing of a full size model of a wind turbine, testing of service and maintenance of the main components (nacelle, blade, generator, gear box, transformer), and testing of access to the wind turbine. A low number of turbines must demonstrate a sufficient trial period (onshore or offshore).
- Series production should be accompanied by factory acceptance tests and quality assurance and control.
- The basic requirement for the first offshore wind farms is stable, structured financial support in situations where basic experience in operating and financing such projects is lacking. If this basic requirement is not met, the project will take much longer, and may even ultimately fail. Offshore wind energy utilisation is a young business sector which needs stable framework conditions to support its development.

## 10.6 Outlook for further activities

Further activities should concentrate on measures to reduce costs and reach higher efficiency of the whole process. In particular, the focus should be on the following aspects:

- Stable and positive conditions for offshore wind energy development
- Advantage and disadvantages of EPC contracting / multi-contracting
- Spatial planning for wind farm sites and cable routes
- Coordinated approval procedure for wind farm, cable to shore and onshore cable – if necessary: extension / reinforcement of the transmission grid
- Extended pre-testing and evaluation before serial production, quality control during production
- Good accessibility of a logistical centre, and sufficient space in the harbour / at quayside
- Avoidance of offshore work.

**Bibliography:**

- Aarsleff “Offshore wind farm at Rødsand”, Abyhøj, 2004
- Andersen, Boesen “Environmental issues concerning offshore wind farms”, 2004
- Andersen, Steffen; Boesen, Charlotte “Environmental issues concerning offshore wind farms: experiences from the Horns Rev and Nysted Offshore Wind Farms”, EWEC 2004, London
- BWEA “Best practise guidelines: Consultation for offshore wind energy developments”, 2002
- Chatteron, Adrian, “Scroby Sands”, E.ON UK Renewables, November 2005
- Coyle, Anne-Marie “Scroby Sands Offshore Wind Farm Update”, April 2002
- Douglas Westwood and ode operations “Scroby Sands- supply chain analysis”, DWL Report Number 334-04
- Greater Gabbard Offshore Winds Ltd “Environmental statement - Greater Gabbard Offshore Wind Farm”, October 2005
- Hansen, Niels-Erik Ottensen; Gislason, Kjartan “Movable scour protection on highly erodible sea bottom”, Hellerup, Denmark
- Judd, Adrian “Offshore wind parks in Great Britain and the project collaborative offshore wind research into the environment (COWRIE)” Centre for Environment, Fisheries and Aquaculture Science (CEFAS), [www.erneuerbare-energien.de](http://www.erneuerbare-energien.de)
- Lisby, Joergen; Jacobsen, Jesper “Installation – concepts and risks”, Per Aarsleff A/S, Copenhagen Offshore Wind 2005
- Madsen, Morton “Roedsand Offshore Wind Farm”, Esbjerg 2004
- Marine Consents and Environment Unit “Licence No 31272/02/0”, 2002
- Offshore Centre Denmark, “Newsletter On/OFF 3”, August 2004
- Pedersen, Per Hjelmsted “Nysted Offshore – success down to hard work”, Wind Kraft Journal 4/2004
- Pedersen, Per Hjelmsted “Energie E2 as an operator of offshore wind farms: the Nysted project, technology considerations, international consent procedures” Conference *Windforce05 Course offshore*, Bremerhaven, May 2005
- POWER Project – “Offshore wind supply chain study for Denmark - supply chain in a globalized world”, Report – September 2005
- POWER Project “Offshore wind energy in the north sea region”, Report, September 2005
- SEAS-NVE Energy Group “Offshore Wind Farms”, Denmark, Brochure 2005
- Skjoerboek, Poul, “A logistic challenge” in ON/OFF-Newsletter, Offshore Centre Denmark, August 2004
- Stiesdal, Henrik “Nysted offshore – success down to hard work” BONUS Energy A/S, Wind Kraft Journal 5/2004
- Volund, Pedersen, Ter-Borch “165 Nysted offshore wind Farm. First year of operation - performance as planned” Copenhagen, 2005
- Ballast Nedam Infra (2005) Ballast Nedam Offshore Energy, available at <http://www.offshore-energy.nl:8080/offshore/>, last visited 24th November 2005

COD (2005) Work Package 3: Report on legal and administrative issues, Concerted action for Off-shore Wind Energy Deployment and SenterNovem

Commissie MER (2003) Toetsingsadvies over het milieueffectrapport Inrichting demonstratiepark Near Shore Windpark 27 november 2003, nr. 1287-168, Commissie MER, Utrecht

Kouwenhoven, H., M. Haag, J. Olthoff, H. den Rooijen, I. McMorrine, P. van Dijke, J. Dekkers and B. Hoefakker (2005) Go ahead Dutch offshore wind farm: Windfarm Egmond aan Zee is under construction, poster presented at Copenhagen Offshore Wind Conference, 26 – 28 October 2005

Ministry of Economic Affairs (2004) Connect 6000, Ministry of Economic Affairs and SenterNovem, The Hague

NoordzeeWind (2002) Startnotitie. Milieu-effectrapportage inrichting demonstratieproject Near Shore Windpark (Start document spatial configuration EIA Near Shore Wind Farm), submitted to Ministry of Housing, Spatial Planning and Environment, July 2002

NoordzeeWind (2003a) Wbr/Wm vergunningaanvraag – Near Shore Windpark (PWA/EMA consent application – Near Shore Wind farm), submitted to Ministry of Public Works, Transport and Water Management, March 2003

NoordzeeWind (2003b) Inrichtings-milieueffectrapport Near Shore Windpark (Spatial configuration EIA Near Shore Wind Farm), Grontmij en NoordzeeWind, June 2003

Offshore Windenergie (2005a) Planned wind farms, [www.windopzee.nl/kaart.asp?id=14](http://www.windopzee.nl/kaart.asp?id=14), last visited 23 May 2005

Offshore Windenergie (2005b) Monitoring en Evaluatieprogramma, [http://www.windopzee.nl/default.asp?DOC\\_ID=23592](http://www.windopzee.nl/default.asp?DOC_ID=23592), last visited 8 October 2005

[www.a2sea.com](http://www.a2sea.com)

[www.alnmaritec.co.uk](http://www.alnmaritec.co.uk)

[www.ballast-nedam-offshore-energy.com](http://www.ballast-nedam-offshore-energy.com)

[www.eide-gruppen.no](http://www.eide-gruppen.no)

[www.eon-uk.com](http://www.eon-uk.com)

[www.ewea.org](http://www.ewea.org)

[www.greatergabbard.com](http://www.greatergabbard.com)

[www.ihcholland.com](http://www.ihcholland.com)

[www.mammoetvanoord.com](http://www.mammoetvanoord.com)

[www.oceanteam.nl](http://www.oceanteam.nl)

[www.ode-ltd.co.uk](http://www.ode-ltd.co.uk)

[www.offshore-technology.com](http://www.offshore-technology.com)

[www.seacore.co.uk/](http://www.seacore.co.uk/)

[www.wt-henley.com](http://www.wt-henley.com)

**Private Communication:**

Steen Beck Nielsen and Eric Jacobsen, SEAS-NVE Energy Group, October and December 2005

Kurt E. Thomson, A2Sea, September 2005

Fried Hendrikx, SIF, September 2005

Koen Baeten, Smulders, September 2005

Egbert van't Hooft, IHC Hydrohammer, September 2005

Rolf Balthes, FUGRO, September 2005

Jon Mears, Mike Chew and Jan Ross, Oceanteam, September 2005

Adrian Chatterton, E.ON UK Renewables, October 2005

Brian Boutkan, Mammoet van Oord, October 2005

Chris Hill and Chris Veal, Airtricity, October and December 2005

Helge Gravensen, Carl Bro, October and December 2005

Jesper Kristian Jacobsen, Per Aasleff, October 2005

Michael Neumaier, F+Z Baugesellschaft, October 2005

Per Hjelmsted Pederson, ENERGI E2, October 2005

Dan Woodmann, ode operations, November and December 2005

Ingo de Buhr, H. Klemt, Freerk Nanninga, Prokon Nord, October and December 2005

Jens Bonefeld, Elsam Engineering October 2005

Hermann Albers, Wolfgang Paulsen, September and December 2005

Mr. H. Boomsma. Policy advisor at the directorate for energy production, Directorate-General for Energy, Ministry of Economic Affairs, The Netherlands. 19 October 2005.

Mr. J. Dunselman. Policy advisor Housing and Spatial Planning, municipality of Velsen. 31 October 2005

Mr. R. van den Heuvel. Policy advisor at the North Sea Directorate, Directorate-General for Public Works and Water Management, Ministry of Public Works, Transport and Water Management. 14 November 2005.

Mr. H. den Rooijen. Project General Manager of Noordzeewind. 14 November 2005.

Ms. L. Schoof. Coordinator of Communication Service of the municipality of Bergen. Telephonic interview, 9 November 2005.